



**SCTE&VT**

State Council for Technical Education &  
Vocational Training  
Government of Odisha



**LECTURE NOTES**  
**ON**  
**Land Survey-II (Th.1)**  
**Diploma 6<sup>th</sup> Semester**

**DEPARTMENT OF CIVIL ENGINEERING**  
**Govt. Polytechnic, Nayagarh**

# SYLLABUS

## **1 TACHEOMETRY:** (Only concepts; applications without derivation)

- 1.1 Principles, stadia constants determination
- 1.2 Stadia tacheometry with staff held vertical and with line of collimation horizontal or inclined, numerical problems
- 1.3 Elevations and distances of staff stations – numerical problems

## **2 CURVES :**

- 2.1 compound, reverse and transition curve, Purpose & use of different types of curves in field
- 2.2 Elements of circular curves, numerical problems
- 2.3 Preparation of curve table for setting out
- 2.4 Setting out of circular curve by chain and tape and by instrument angular methods (i) offsets from long chord, (ii) successive bisection of arc, (iii) offsets from tangents, (iv) offsets from chord produced, (v) Rankine's method of tangent angles (No derivation)
- 2.5 Obstacles in curve ranging – point of intersection inaccessible

## **3 BASICS ON SCALE AND BASICS OF MAP:**

- 3.1 Fractional or Ratio Scale, Linear Scale, Graphical Scale
- 3.2 What is Map, Map Scale and Map Projections
- 3.3 How Maps Convey Location and Extent
- 3.4 How Maps Convey characteristics of features
- 3.5 How Maps Convey Spatial Relationship
  - 3.5.1 Classification of Maps
    - 3.5.1 Physical Map
    - 3.5.2 Topographic Map
    - 3.5.3 Road Map
    - 3.5.4 Political Map
    - 3.5.5 Economic & Resources Map
    - 3.5.6 Thematic Map
    - 3.5.7 Climate Map

## **4 SURVEY OF INDIA MAP SERIES:**

- 4.1 Open Series map
- 4.2 Defense Series Map
- 4.3 Map Nomenclature
  - 4.3.1 Quadrangle Name
  - 4.3.2 Latitude, Longitude, UTM's
  - 4.3.4 Contour Lines
  - 4.3.5 Magnetic Declination
  - 4.3.6 Public Land Survey System
  - 4.3.7 Field Notes

## **5 BASICS OF AERIAL PHOTOGRAPHY, PHOTOGRAMMETRY, DEM AND ORTHO IMAGE GENERATION:**

- 5.1 Aerial Photography:
  - 5.1.1 Film, Focal Length, Scale
  - 5.1.2 Types of Aerial Photographs (Oblique, Straight)

## 5.2 Photogrammetry:

### 5.2.1 Classification of Photogrammetry

### 5.2.2 Aerial Photogrammetry 5.2.3 Terrestrial Photogrammetry

### 5.3 Photogrammetry Process:

#### 5.3.1 Acquisition of Imagery using aerial and satellite platform

#### 5.3.2 Control Survey

#### 5.3.3 Geometric Distortion in Imagery Application of Imagery and its

support data Orientation and Triangulation Stereoscopic Measurement 19.9.1 X-parallax 19.2.2 Y-parallax

### 5.4 DTM/DEM Generation

### 5.5 Ortho Image Generation

## **6 MODERN SURVEYING METHODS :**

6.1 Principles, features and use of (i) Micro-optic theodolite, digital theodolite

6.2 Working principles of a Total Station (Set up and use of total station to measure angles, distances of points under survey from total station and the coordinates (X,Y & Z or northing, easting, and elevation) of surveyed points relative to Total Station position using trigonometry and triangulation.

## **7 BASICS ON GPS & DGPS AND ETS:**

### 7.1 GPS: - Global Positioning

#### 7.1.1 Working Principle of GPS,GPS Signals,

#### 7.1.2 Errors of GPS,Positioning Methods

### 7.2 DGPS: - Differential Global Positioning System

#### 7.2.1 Base Station Setup

#### 7.2.2 Rover GPS Set up

#### 7.2.3 Download, Post-Process and Export GPS data

#### 7.2.4 Sequence to download GPS data from flashcards

#### 7.2.5 Sequence to Post-Process GPS data

#### 7.2.6 Sequence to export post process GPS data

#### 7.2.7 Sequence to export GPS Time tags to file

### 7.3 ETS: - Electronic Total Station

#### 7.3.1 Distance Measurement

#### 7.3.2 Angle Measurement

#### 7.3.3 Leveling

#### 7.3.4 Determining position

#### 7.3.5 Reference networks

#### 7.3.6 Errors and Accuracy

## **8 BASICS OF GIS AND MAP PREPARATION USING GIS**

### 8.1 Components of GIS, Integration of Spatial and Attribute Information

### 8.2 Three Views of Information System

#### 8.2.1 Database or Table View, Map View and Model View

### 8.3 Spatial Data Model

### 8.4 Attribute Data Management and Metadata Concept

### 8.5 Prepare data and adding to Arc Map.

### 8.6 Organizing data as layers.

- 8.7 Editing the layers.
- 8.8 Switching to Layout View.
- 8.9 Change page orientation.
- 8.10 Removing Borders.
- 8.11 Adding and editing map information.
- 8.12 Finalize the map

# TACHEOMETRY

## **Tacheometric Surveying:**

Tacheometric is a branch of surveying in which horizontal and vertical distances are determined by taking angular observation with an instrument known as a tachometer. Tacheometric surveying is adopted in rough and difficult terrain where direct levelling and chaining are either not possible or very tedious.

Tacheometric survey also can be used for Railways, Roadways, and reservoirs etc. Tacheometric surveying is very rapid, and a reasonable contour map can be prepared for investigation works within a short time on the basis of such survey.

An ordinary transit theodolite fitted with a stadia diaphragm is generally used for tacheometric surveying.

The stadia diaphragm essentially consists of one stadia hair above and the other an equal distance below the horizontal cross hair, the stadia hair being mounted in the same ring and in the same vertical plane as the horizontal and vertical cross-hair.

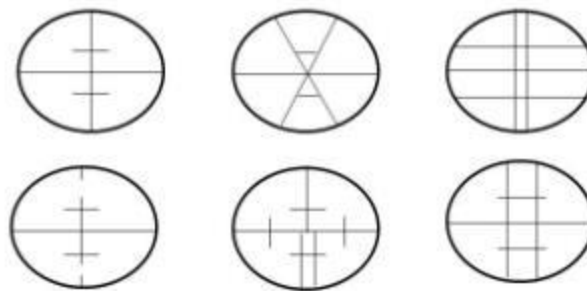

**Fig:** Stadia Diaphragm

## **Advantages of Tacheometry:**

Since both the quantities viz., horizontal distances and the difference of elevations are determined indirectly in tacheometric surveying, it has a number of advantages over the direct methods of measurement of these quantities. In terrain where direct methods are not convenient, tacheometric methods can be used. Tacheometric methods are convenient for reconnaissance surveys of routes, for hydrographic surveying and for filling in details in a traverse. There is considerable saving in time and money with the use of tacheometric methods.

## **Uses of Tachometry:**

Tachometry is used for preparation of topographic map where both horizontal and vertical distances are required to be measured; survey work in difficult terrain where direct methods of measurements are inconvenient; reconnaissance survey for highways and railways etc.; Establishment of secondary control points.

## **Difference between Levelling and Stadia Staff Rod:**

For short sights of about 100 m or less, an ordinary levelling staff may be used. For long sights, special staff called stadia rod is generally used. The graduations are in bold type (face about 50 mm to 150 mm wide and 15 mm to

60 mm thick) and the stadia rod is 3 m to 5 m long. To keep the staff or stadia rod vertical, a small circular spirit level is fitted on its backside. It is hinged to fold up.

### **Anallactic Lens:**

The basic formula for determination of horizontal distance in stadia tacheometry is

$$D = \frac{fs}{i} + (f + c)$$

$$D = Ks + C \text{ (Proved after this section)}$$

Due to the presence of the additive constant  $C$ ,  $D$  is not directly proportional to  $s$ . This is accomplished by the introduction of an additional convex lens in the telescope, called an anallactic lens, placed between the eyepiece and object glass, and at a fixed distance from the latter. The anallactic lens is provided in external focusing telescope. Its use simplifies the reduction of observations since the additive constant  $(f + c)$  is made zero and the multiplying constant  $k$  is made 100.

### **Different systems of Tacheometric Measurement:**

The various systems of tacheometric survey may be classified as follows,

#### ❖ **The Stadia Method**

- Fixed Hair Method and
- Movable Hair Method

#### ❖ **The Tangential System**

#### ❖ **Subtense Bar System**

### **Stadia systems:**

In this systems staff intercepts, at a pair of stadia hairs present at diaphragm, are considered. This is the more extensively used system of tacheometry particularly for detailed work, such as those required in engineering surveys. In this system, a tacheometer is first set up at a station, say  $P$ , and a staff is held at station  $Q$ , as shown in Figure given below. The difference of upper hair reading and lower hair reading is called staff intercept  $s$ . All the three hairs including central cross hair are read, and  $s$  is determined. Vertical angle,  $\theta$ , corresponding to the central hair is also measured. These measurements enable determination of horizontal distance between  $P$  and  $Q$  and their difference in elevation.

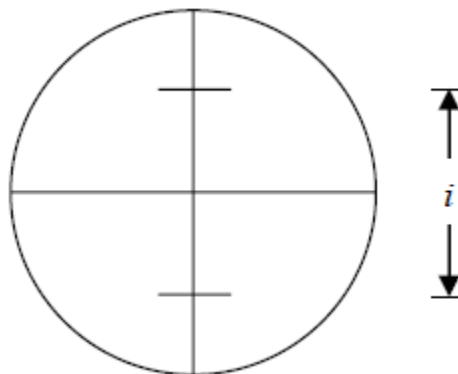

The stadia system consists of two methods:

- Fixed-hair method and
- Movable-hair method

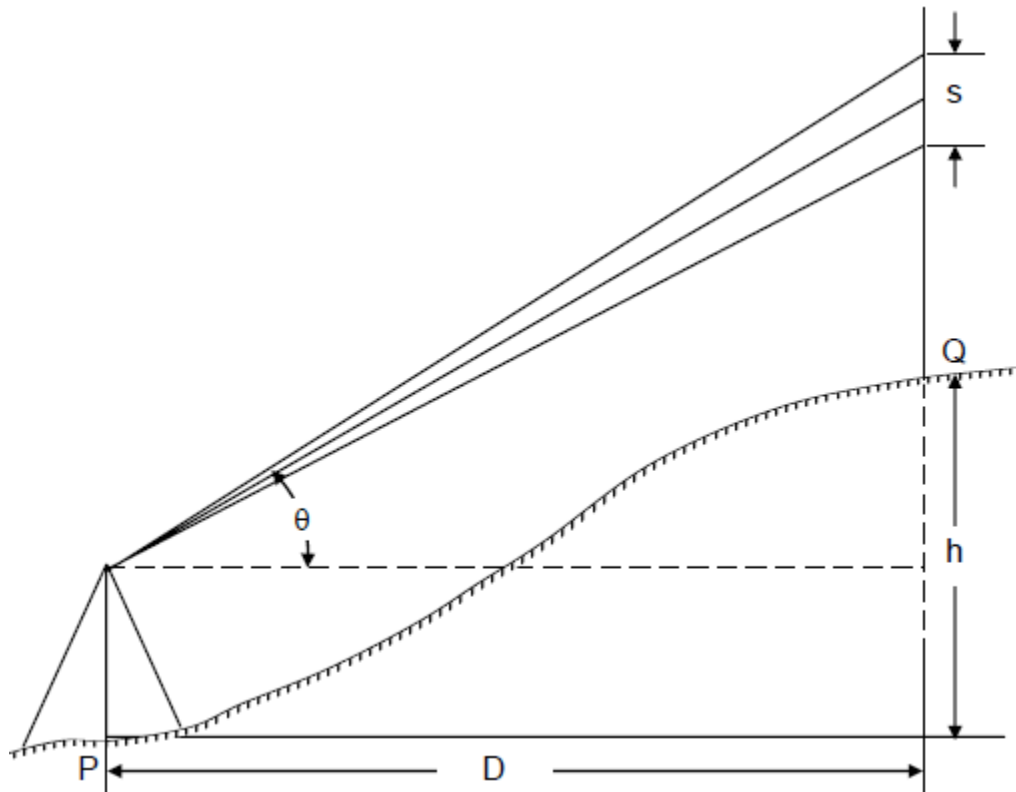

### **Fixed-hair method:**

In this method, stadia hairs are kept at fixed interval and the staff interval or intercept (corresponding to the stadia hairs) on the levelling staff varies. Staff intercept depends upon the distance between the instrument station and the staff. In this method, the distance between the upper hair and lower hair, i.e. stadia interval  $i$ , on the diaphragm of the lens system is fixed. The staff intercept  $s$ , therefore, changes according to the distance  $D$  and vertical angle  $\theta$ .

### **Movable- hair method:**

In this method, the staff interval is kept constant by changing the distance between the stadia hairs. Targets on the staff are fixed at a known interval and the stadia hairs are adjusted to bisect the upper target at the upper hair and the lower target at the lower hair. Instruments used in this method are required to have provision for the measurement of the variable interval between the stadia hairs. As it is inconvenient to measure the stadia interval accurately, the movable hair method is rarely used.

### **Tangential method:**

In this method, readings at two different points on a staff are taken against the horizontal cross hair and corresponding vertical angles are noted. In this system, observations are not taken on stadia hairs. Instead vertical angles  $\theta_1$  and  $\theta_2$  to the two targets fixed on a staff are recorded shown in the Figure given below. The targets are at a fixed distance  $s$ . Vertical angles  $\theta_1$ ,  $\theta_2$  and staff intercept  $s$  enable horizontal distance  $D$  and the difference of elevations to be determined.

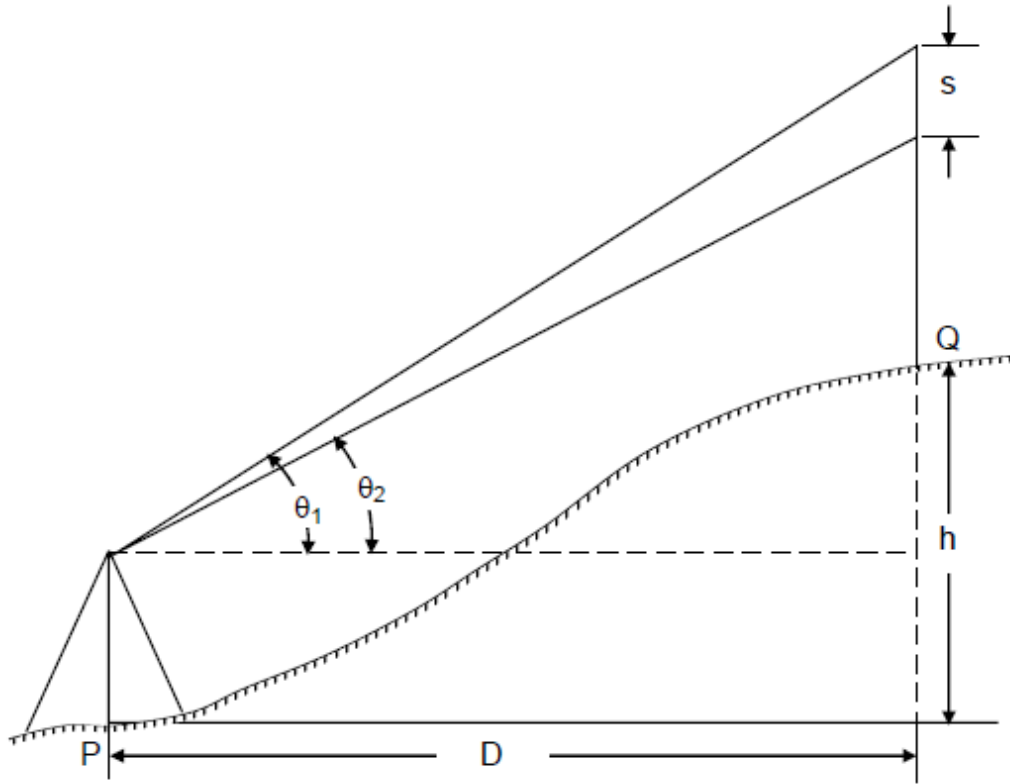

### Subtense Bar System:

Subtense bar is a bar of fixed length generally 2 m fitted with two targets at the ends. The targets are at equal distance apart from the centre. The subtense bar can be fixed on a tripod stand and is kept horizontal. As shown in Figure given below, angle  $\alpha$  subtended by the two targets at station **P** is measured by a theodolite. The distance **s** between the targets and the angle  $\alpha$  enable the distance **D** between station **P** and **Q** to be determined.

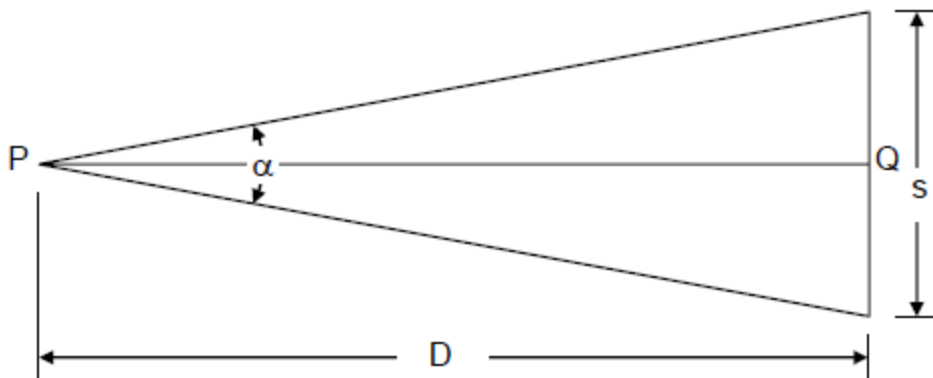

### Principle of Stadia Method:

The derive distance and elevation formulae for fixed hair method assuming line of sight as horizontal and considering an external focusing type telescope. In the figure, **O** is the optical centre of the object glass. The three stadia hairs are **a**, **b** and **c** and the corresponding readings on staff are **A**, **B** and **C**. Length of image of **AB** is **ab**. The other terms used in this figure are

$f = \text{focal length of the object glass,}$



$i = \text{stadia hair interval} = ab$ ,  
 $s = \text{staff intercept} = AB$ ,  
 $c = \text{distance from } O \text{ to the vertical axis of the instrument,}$   
 $d = \text{distance from } O \text{ to the staff,}$   
 $d'' = \text{distance from } O \text{ to the plane of the diaphragm, and}$   
 $D = \text{horizontal distance from the vertical axis to the staff.}$

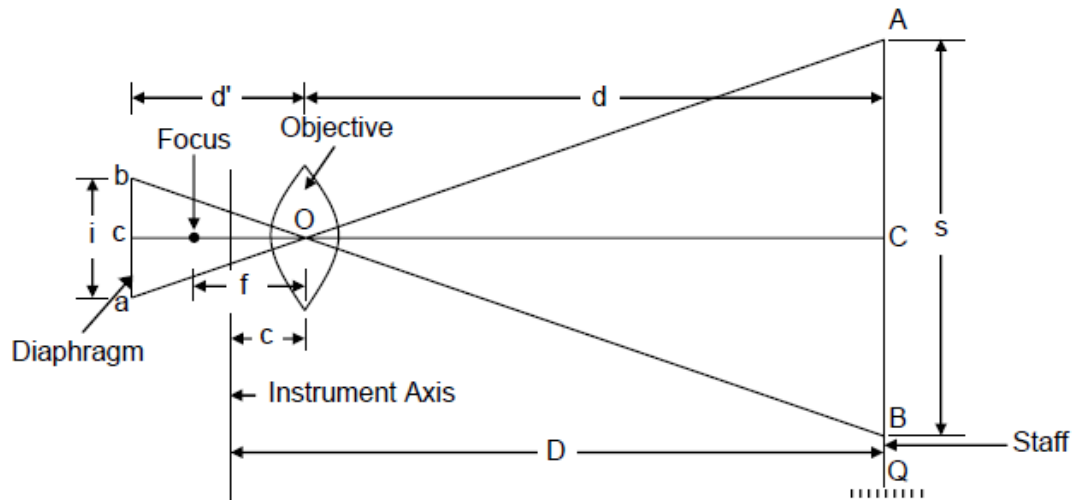

From similar  $\Delta$ ,  $AOB$  and  $aOb$ , we get

$$\frac{d}{d'} = \frac{s}{i}$$

And from lens formula,  $\frac{1}{f} = \frac{1}{d'} + \frac{1}{d}$

By combining the two equations, we get

$$d = \frac{fs}{i} + f$$

Adding  $c$  to both the sides,  $D = \frac{fs}{i} + (f + c)$

$$D = Ks + C$$

Where the constant  $K$  is equal to  $(f/i)$ . It is called **Multiplying Constant** of the tacheometer and is generally kept as 100. The constant  $C$  is equal to  $(f + c)$ . It is called **Additive Constant**.

### Tangential Method:

The method of tangential tacheometry can be used when staff is held much away from the instrument making it difficult to read it. This method is useful when the diaphragm does not have stadia hairs. The staff used in this method is similar to the one employed in movable hair method. The distance between the target vanes may be 2 m or 3 m. Vertical angles  $\theta_1$  and  $\theta_2$  to the top and bottom targets are measured from the instrument station. The horizontal distance  $D$  and the vertical intercept  $V$  are computed from the values of  $s$ ,  $\theta_1$  and  $\theta_2$ . Depending upon the angles (i.e., angles of **elevation or depression**), there can be three case. These are described below.

### CASE-I: Both the Angles are of Elevation

When the ground does not permit a horizontal sight, two vertical angles  $\theta_1$  and  $\theta_2$  are measured as shown in Figure.

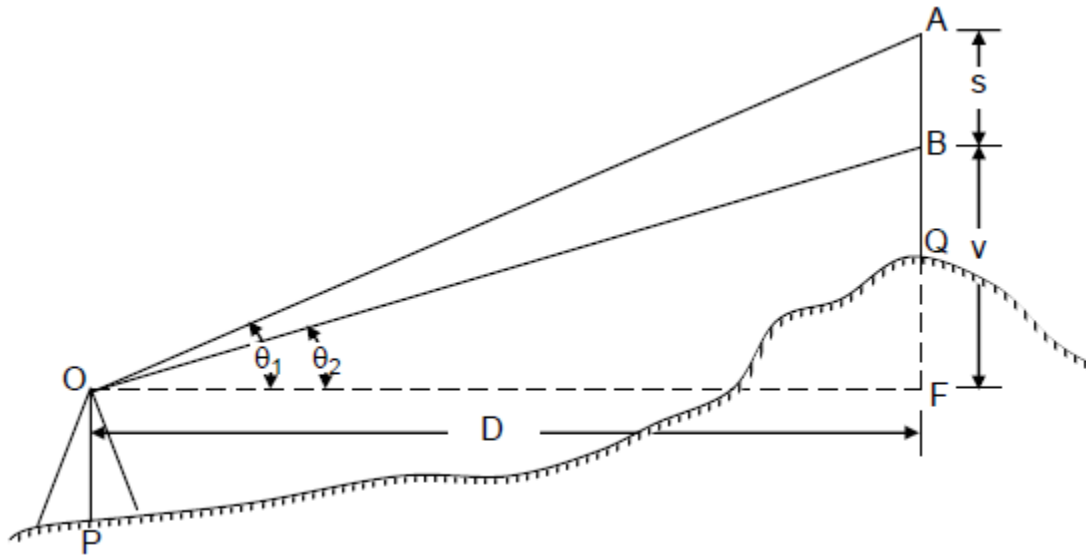

Now  $AF = D \tan \theta_1$  and  $BF = D \tan \theta_2$

$$S = AF - BF = D (\tan \theta_1 - \tan \theta_2)$$

$$D = \frac{S}{\tan \theta_1 - \tan \theta_2} \text{ and } V = D \times \tan \theta_2$$

Knowing HI, i.e., the height of the axis of the instrument above datum, the elevation of Q is given as,

$$RL \text{ of } Q = HI + FB - QB$$

$$= HI + D \cdot \tan \theta_2 - QB$$

### CASE-II: Both the Angles are of Depression

From Figure

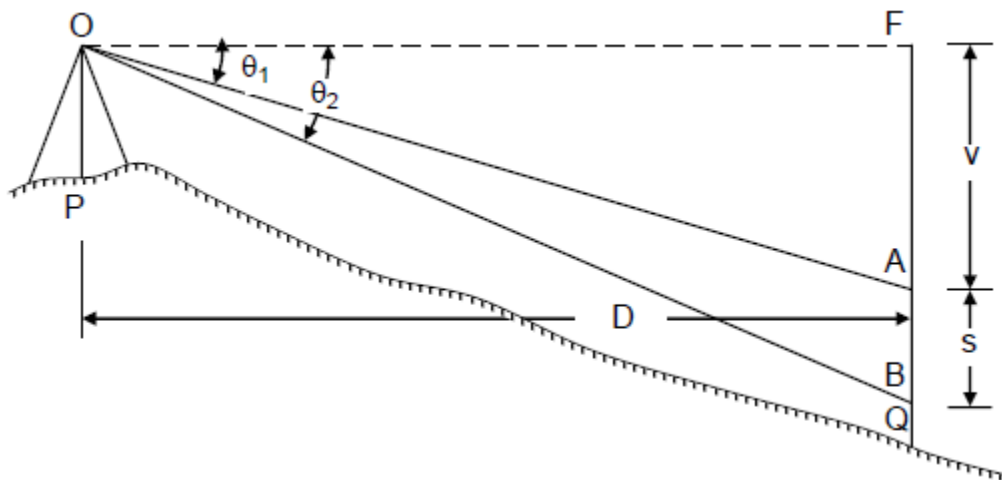

$$S = BF - AF$$

$$D = \frac{S}{\tan \theta_2 - \tan \theta_1} \text{ and } V = D \times \tan \theta_1$$

$$RL \text{ of } Q = HI - D \tan \theta_1 - s - QB$$

**CASE-III: One Angle of Elevation and another Angle of Depression:**

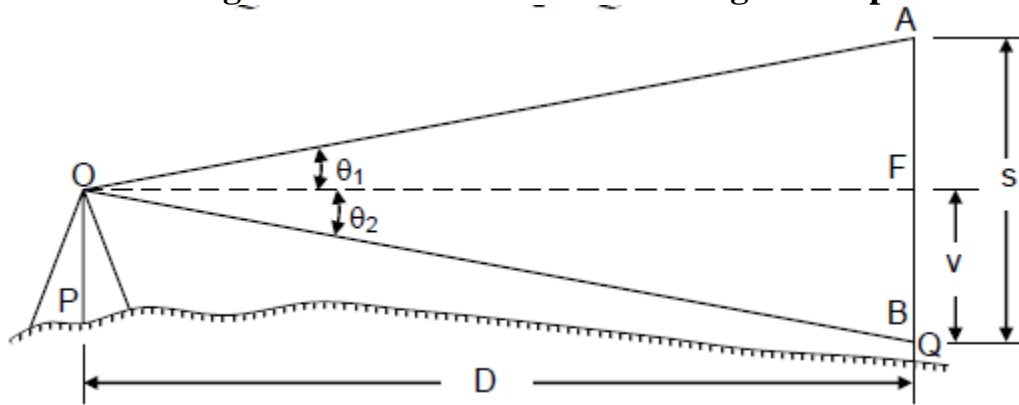

Now  $AF = D \tan \theta_1$  and  $BF = D \tan \theta_2$

$S = AF + BF = D (\tan \theta_1 + \tan \theta_2)$

$D = \frac{S}{\tan \theta_1 + \tan \theta_2}$  and  $V = D \times \tan \theta_2$

$RL \text{ of } Q = HI - D \cdot \tan \theta_2 - QB$

# CURVES

## Compound, Reverse and Transition Curve, Purpose & Use of Different Types of Curves in Field :

The centre line of a road consists of series of straight lines interconnected by curves that are used to change the alignment, direction, or slope of the road. Those curves that change the alignment or direction are known as **horizontal curves**, and those that change the slope are **vertical curves**. When a highway changes horizontal direction, making the point where it changes direction a point of intersection between two straight lines is not feasible. The change in direction would be too abrupt for the safety of modern, high-speed vehicles. It is therefore necessary to interpose a curve between the straight lines. The straight lines of a road are called **tangents** because the lines are tangent to the curves used to change direction.

Horizontal curves are further classified as **circular curves** and **transition curves**.

A curve may be simple, compound, reverse, or spiral (figure ). Compound and reverse curves are treated as a combination of two or more simple curves, whereas the spiral curve is based on a varying radius.

### Simple circular curve:

The simple curve is an arc of a circle. It is the most commonly used. The radius of the circle determines the “sharpness” of the curve. The larger the radius, the “flatter” the curve.

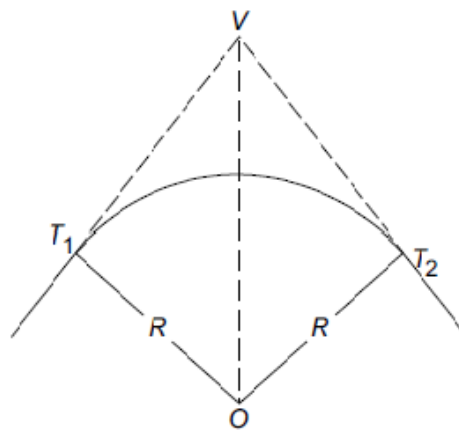
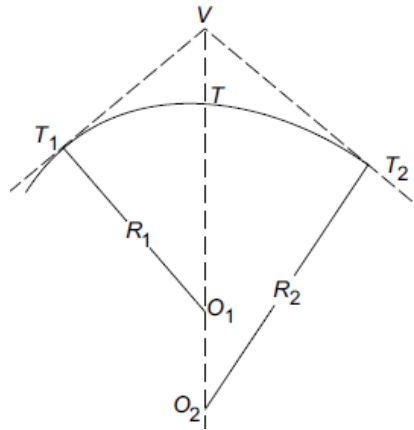

Fig: Simple Circular Curve

### Compound Curve:

Surveyors often have to use a compound curve because of the terrain. This normally consists of two simple curves curving in the same direction and joined together.



**Fig: Compound Curve**

**Spiral Curve:**

The spiral is a curve with varying radius used on railroads and some modern highways. It provides a transition from the tangent to a simple curve or between simple curves in a compound curve.

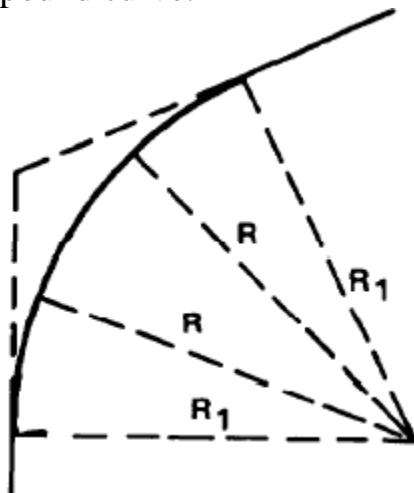

**Elements of a simple curve:**

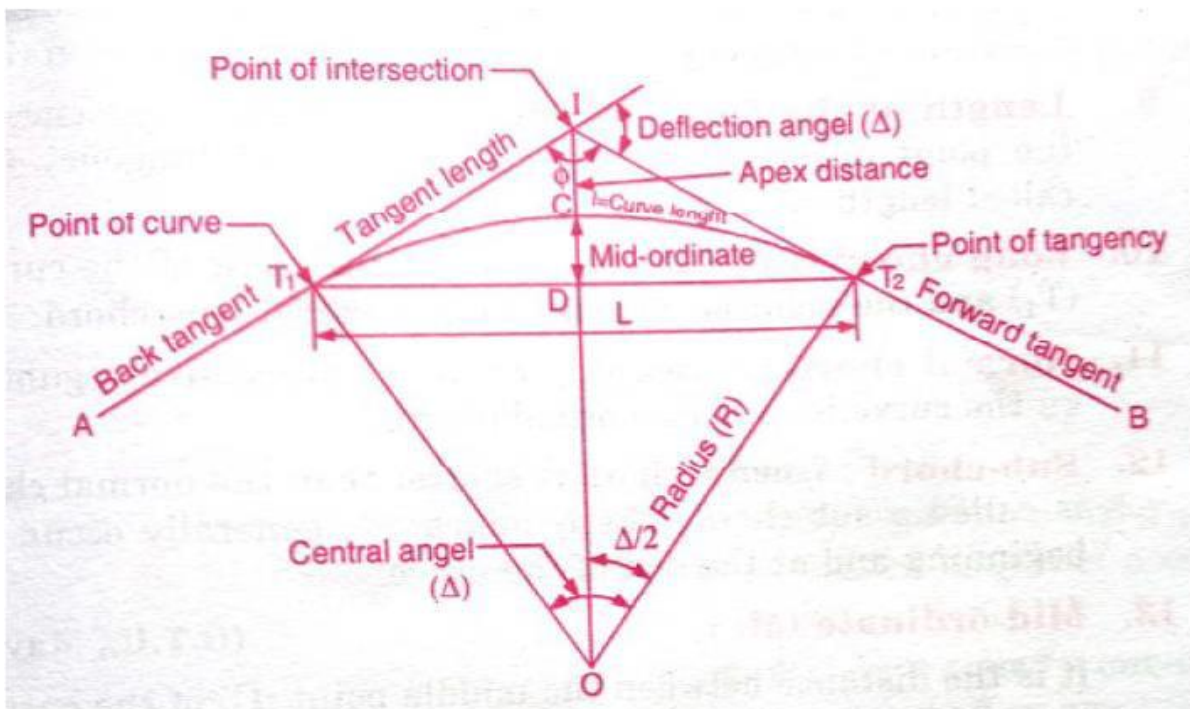

**Fig: Elements of Simple Curve**

From above Figure:

$T_1 = P.C.$  = Point of tangency=Point of curve.

$T_2 = P.T.$  = Second point of tangency.

V or I = P.I. = Point of intersection.

$\Delta$  = Deflection angle.

$\emptyset$  = Intersection angle.

R = Radius of curve.

CD= Mid ordinate (M)

**Radius:** The radius of the circle of which the curve is an arc, or segment. The radius is always perpendicular to back and forward tangents.

**Point of intersection:** The point of intersection is the theoretical location where the two tangents meet.

**Point of tangency (PT):** The point of tangency is the point on the forward tangent where the curve ends.

**Intersecting Angle (I):** The intersecting angle is the deflection angle at the PI. The surveyor either computes its value from the preliminary traverse station angles or measures it in the field.

**Point of Curvature (PC):** The point of curvature is the point where the circular curve begins. The back tangent is tangent to the curve at this point.

**Length of Curve (L):** The length of curve is the distance from the PC to the PT measured along the curve.

**Long Chord (LC):** The long chord is the chord from the PC to the PT.

**Tangent Distance (T):** The tangent distance is the distance along the tangents from the PI to the PC or PT. These distances are equal on a simple curve.

**Central Angle ( $\Delta$ ):** The central angle is the angle formed by two radii drawn from the center of the circle (O) to midpoint of the curve to the the PC and PT. The central angle is equal in value to the I angle.

**Middle ordinate (M):** The middle ordinate is the distance from the midpoint of the curve to the midpoint of the long chord. The extension of the middle ordinate bisects the central angle.

**Degree of Curve (D):**

In Great Britain the sharpness of the curve is designated by the radius of the curve while in India and many countries it is designated by the degree of curvature. There are two different definitions of degree of curvature:

- i. Arc Definition [**Figure (a)**]
- ii. Chord Definition. [**Figure (b)**]

According to arc definition degree of curvature is defined as angle in degrees subtended by an arc of standard length shown in the figure below. This definition is generally used in highway practice. The length of standard arc is taken as 30 m. Some people take it as 20 m also.

According to chord definition degree of curvature is defined as angle in degrees subtended by a chord of standard length shown in the figure below. This definition is commonly used in railways.

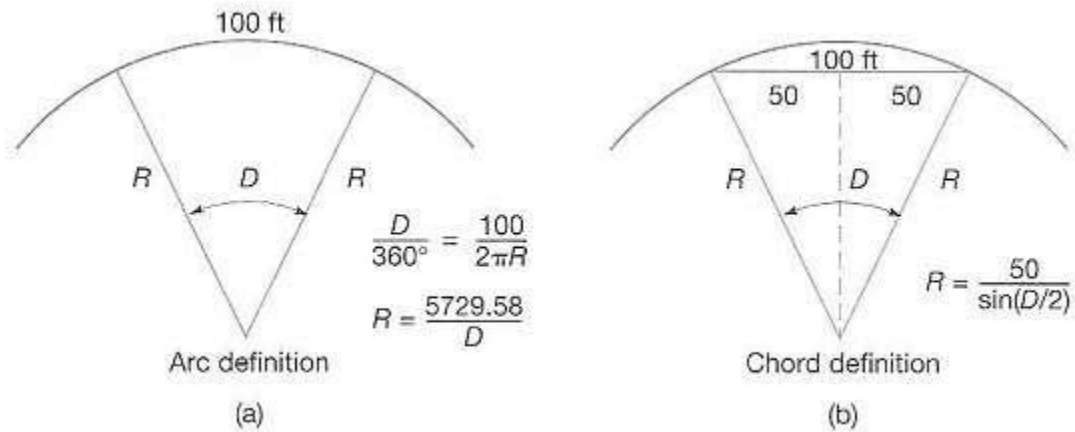

### Important Elements of Curve:

#### A. Length of Curve (l):

The length of the curve (L) =  $\frac{2\pi R\Delta}{360}$

#### B. Tangent Length (T):

Tangent Length =  $R \tan (\Delta/2)$

#### C. Length of Long Cord (L):

Length of Long Chord =  $2 R \sin (\Delta/2)$

#### D. Mid-ordinate (M): =

The Mid Ordinate =  $R [1 - \cos (\Delta/2)]$

#### E. Apex Distance / External Distance:

The external distance =  $R [\text{Sec} (\Delta/2) - 1]$

### Setting out a Simple Circular Curve:

After aligning the road/railway along AA', when curve is to be inserted, alignment of B'B is laid on the field by carefully going through the alignment map and field notes

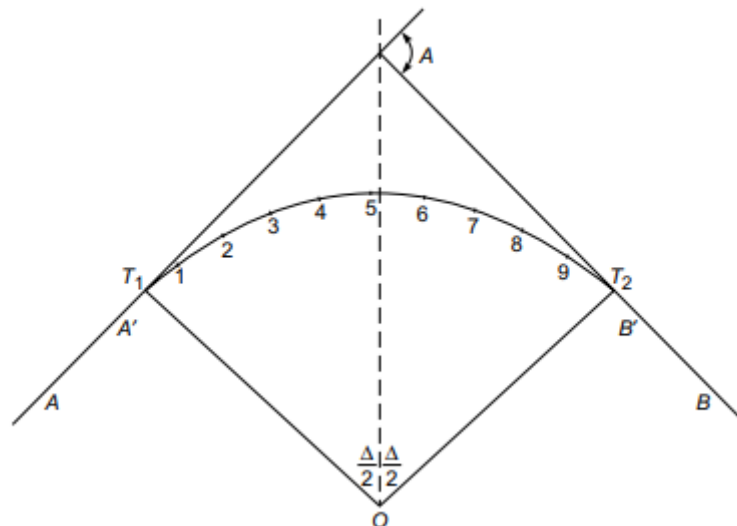

**Fig:** Setting out of Simple Circular Curve

By ranging from AA' and BB', the vertex point V is determined. Setting a theodolite at V, the deflection angle is measured carefully. The tangent distance T<sub>1</sub> is calculated. Subtracting this value from chainage of V, chainage of point of

curve  $T_1$  is found. Adding length of curve to this chainage of  $T_2$  can be easily found. Now pegs are to be fixed along the required curve at suitable intervals. It is impossible to measure along the curve. Hence, for fixing curve, chord lengths are taken as curved length. Chord length for peg interval is kept  $\frac{1}{10}$  th to  $\frac{1}{20}$  th of radius of curve. When it is  $\frac{1}{10}$ th of  $R$ , the error is 1 in 2500 and if it is  $\frac{1}{20}$ th  $R$ , the error is 1 in 10,000. In practice the radius of the curve varies from 200 m to 1000 m. Hence, the chord length of 20 m is reasonably sufficient. For greater accuracy it may be taken as 10 m.

In practice, pegs are fixed at full chain distances. For example, if 20 m chain is used, chainage of  $T_1$  is 521.4 m and that of  $T_2$  is 695.8 m, the pegs are fixed at chainages 540, 560, 580 ..., 660, 680 m. Thus, the chord length of first chord is 1.4 m while that of last one is 15.8 m. All intermediate chords are of 20 m. The first and last peg stations are known as sub-chord station while the others are full chord stations.

The various methods used for setting curves may be broadly classified as:

- (i) Linear methods
- (ii) Angular methods.

### Linear Method of Setting out of Simple Circular Curve:

The following are some of the linear methods used for setting out simple circular curves:

- (i) Offsets from long chord
- (ii) Successive bisection of chord
- (iii) Offsets from the tangents—perpendicular or radial
- (iv) Offsets from the chords produced.

#### Offsets from long chord:

In this method, long chord is divided into an even number of equal parts. Taking centre of long chord as origin, for various values of  $x$ , the perpendicular offsets are calculated to the curve and the curve is set in the field by driving pegs at those offsets.

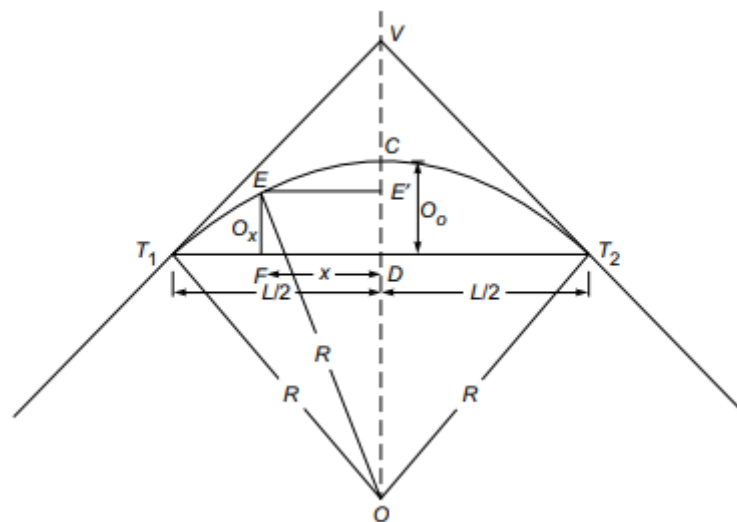

**Fig:** Offset from long chord



Referring to Fig. , let

R – radius of the curve

L – length of long chord

O<sub>0</sub> – mid-ordinate

O<sub>x</sub> – ordinate at distance x from the mid-point of long chord

Ordinate at distance x = O<sub>x</sub> = E'O – DO

$$= \sqrt{R^2 - x^2} - \sqrt{R^2 - (L/2)^2}$$

The above expression holds good for x-values on either side of D, since CD is symmetric axis.

**Successive bisection of chord:**

In this method, points on a curve are located by bisecting the chords and erecting the perpendiculars at the mid-point.

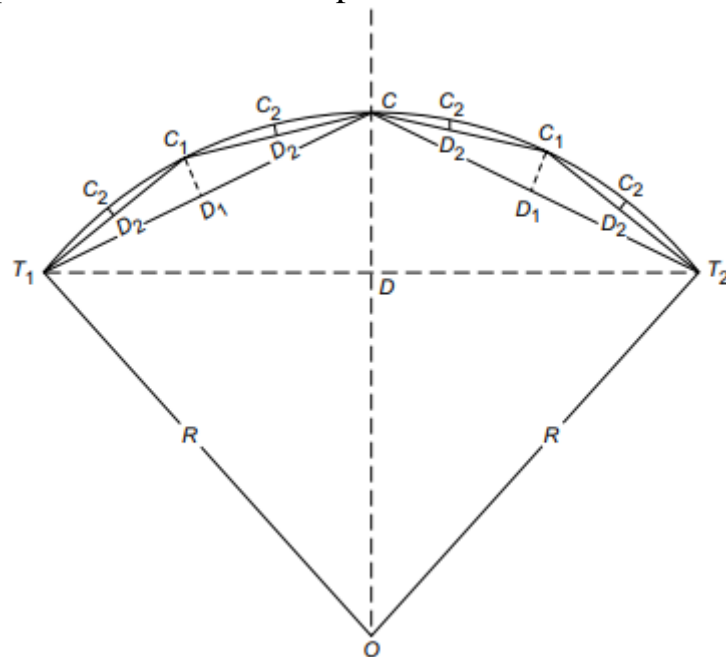

**Fig:** Successive bisection of chord

Referring to Fig.

Perpendicular offset at middle of long chord (D) is

$$CD = R - R \cos \frac{\Delta}{2} = R (1 - \cos \frac{\Delta}{2})$$

Let D<sub>1</sub> be the middle of T<sub>1</sub>C. Then Perpendicular offset

$$C_1D_1 = R(1 - \cos \frac{\Delta}{4})$$

Similarly,

$$C_2D_2 = R(1 - \cos \frac{\Delta}{8})$$

Using symmetry points on either side may be set.

**Offsets from the tangents:**

The offsets from tangents may be calculated and set to get the required curve.

The offsets can be either radial or perpendicular to tangents.

(i) **Radial offsets:** Referring to Fig. , if the centre of curve O is accessible from the points on tangent, this method of curve setting is possible.

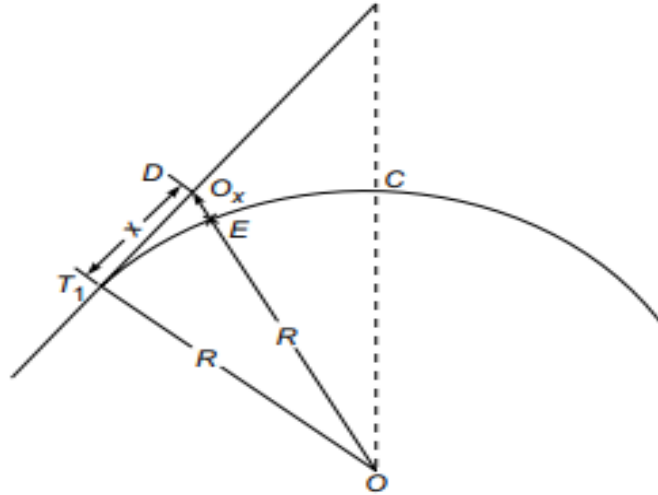

**Fig:** Radial Offset

Let D be a point at distance  $x$  from  $T_1$ . Now it is required to find radial ordinate  $O_x = DE$ , so that the point C on the curve is located.

From  $\Delta OT_1D$ , we get,

$$OD^2 = OT_1^2 + T_1D^2$$

$$(R + O_x)^2 = R^2 + x^2$$

i.e.  $O_x + R = \sqrt{R^2 + x^2}$

or  $O_x = \sqrt{R^2 + x^2} - R$

An approximate expression  $O_x$  may be obtained as explained below:

$$O_x = \sqrt{R^2 + x^2} - R$$

$$= R\sqrt{1 + \left(\frac{x}{R}\right)^2} - R$$

$$\approx R\left(1 + \frac{x^2}{2R^2} - \frac{x^2}{8R^4} + \dots\right) - R$$

Neglecting small quantities of higher order,

$$O_x = R\left(1 + \frac{x^2}{2R^2}\right) - R$$

$$= \frac{x^2}{2R^2} \quad (\text{approx})$$

**(ii) Perpendicular offsets:** If the centre of a circle is not visible, perpendicular offsets from tangent can be set to locate the points on the curve.

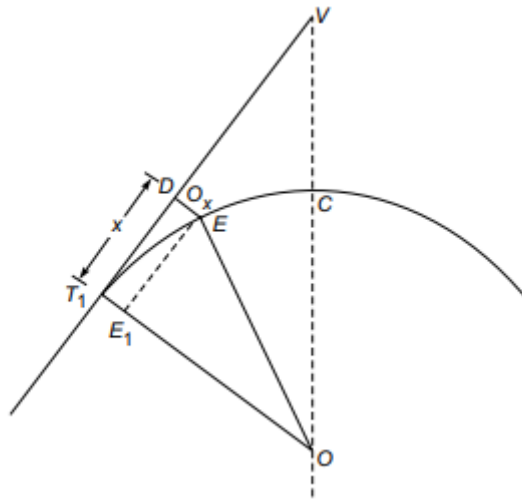

**Fig:** Perpendicular Offset Method

The perpendicular offset  $O_x$  can be calculated as given below:  
Drop perpendicular  $EE_1$  to  $OT_1$ . Then,

$$\begin{aligned}
 O_x &= DE = T_1E_1 \\
 &= OT_1 - OE_1 \\
 &= R - \sqrt{R^2 - x^2} \quad (\text{Exact}) \\
 &= R - R \left( 1 - \frac{x^2}{2R^2} - \frac{x^4}{8R^4} \dots \right) \\
 &= \frac{x^2}{2R} \quad (\text{approx})
 \end{aligned}$$

### Offsets from the chords produced:

This method is very much useful for setting long curves. In this method, a point on the curve is fixed by taking offset from the tangent taken at the rear point of a chord.

Thus, point A of chord  $T_1A$  is fixed by taking offset  $O_1 = AA_1$  where  $T_1A_1$  is tangent at  $T_1$ . Similarly B is fixed by taking offset  $O_2 = BB_1$  where  $AB_1$  is tangent at A.

Let  $T_1A = C_1$  be length of first sub-chord

$AB = C_2$  be length of full chord

$\delta_1 =$  deflection angle  $A_1T_1A$

$\delta_2 =$  deflection angle  $B_1AB$

Then from the property of circular curve

$$T_1OA = 2 \delta_1$$

$$C_1 = \text{chord } T_1A \approx \text{Arc } T_1A = R 2 \delta_1$$

i.e.  $\delta_1 = \frac{C_1}{2R}$  ... (i)

Now, offset  $O_1 = \text{arc } AA_1$   
 $= C_1 \delta_1$  ... (ii)

Substituting the value of  $\delta_1$  from equation (i) into equation (ii), we get

$$O_1 = C_1 \times \frac{C_1}{2R} = \frac{C_1^2}{2R} \quad \dots(2.16)$$

From Fig. 2.11,

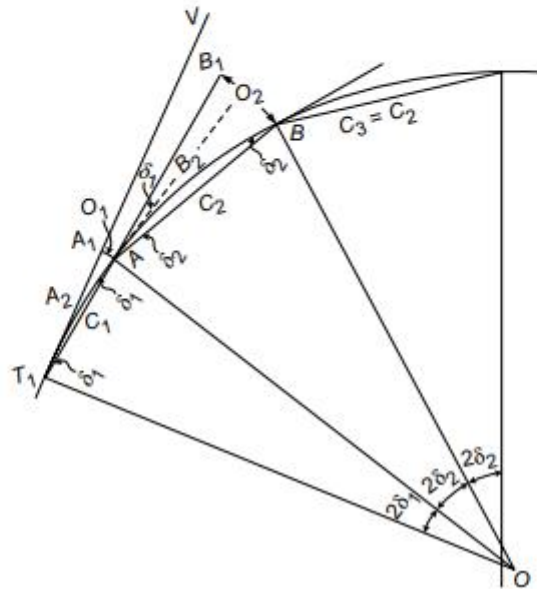

Fig.2.11

$$\begin{aligned} O_2 &= C_2 (\delta_1 + \delta_2) \\ &= C_2 \left( \frac{C_1}{2R} + \frac{C_2}{2R} \right) \\ &= \frac{C_2}{2R} (C_1 + C_2) \end{aligned} \quad \dots(2.17)$$

Similarly,  $O_3 = \frac{C_3}{2R} (C_2 + C_3)$

But,  $C_3 = C_2 \quad \therefore O_3 = \frac{C_2^2}{R}$

Thus, upto last full chord i.e.  $n - 1$  the chord,

$$O_{n-1} = \frac{C_n^2}{2R}$$

If last sub-chord has length  $C_n$ , then,

$$O_n = \frac{C_n}{2R} (C_{n-1} + C_n) \quad \dots(2.18)$$

Note that  $C_{n-1}$  is full chord.

### Procedure for Setting the Curve:

1. Locate the tangent points  $T_1$  and  $T_2$  and find the length of first ( $C_1$ ) and last ( $C_n$ ) sub-chord, after selecting length ( $C_2 = C_3 \dots$ ) of normal chord [Ref Art 2.5].
2. Stretch the chain or tape along  $T_1V$  direction, holding its zero end at  $T_1$ .
3. Swing the arc of length  $C_1$  from  $A_1$  such that  $A_1A = \frac{C_1^2}{2R}$ . Locate  $A$ .
4. Now stretch the chain along  $T_1AB_1$ . With zero end of tape at  $A$ , swing the arc of length  $C_2$  from  $B_1$  till  $B_1B = O_2 = \frac{C_2(C_1 + C_2)}{2R}$ . Locate  $B$ .
5. Spread the chain along  $AB$  and the third point  $C$  such that  $C_2 O_3 = \frac{C_2^2}{R}$  at a distance  $C_3 = C_2$  from  $B$ . Continue till last but one point is fixed.
6. Fix the last point such that offset  $O_n = \frac{C_2(C_2 + C_n)}{2R}$ .
7. Check whether the last point coincides with  $T_2$ . If the closing error is large check all the measurements again. If small, the closing error is distributed proportional to the square of their distances from  $T_1$ .

### Angular Method (Instrumental Method):

The following are the angular methods which can be used for setting circular curves:

- (i) Rankine method of tangential (deflection) angles.
- (ii) Two-theodolite method
- (iii) Tacheometric method

In these methods linear as well as angular measurements are used. Hence, the surveyor needs chain/tape and instruments to measure angles. Theodolite is the commonly used instrument.

### Rankine method of tangential (or Deflection) angles:

A deflection angle to any point on the curve is the angle between the tangent at point of curve ( $PC$ ) and the line joining that point to  $PC$  ( $\Delta$ ). Thus, referring to Fig. 2.13,  $\delta_1$  is the deflection angle of  $A$  and  $\delta_1 + \delta_2$  is the deflection angle of  $B$ .

In this method points on the curve are located by deflection angles and the chord lengths. The formula for calculating deflection angles of various chords can be derived as shown below:

Let  $A, B, C \dots$  be points on the curve. The chord lengths  $T_1A, AB, BC \dots$  be  $C_1, C_2, C_3 \dots$  and  $\delta_1, \delta_2, \delta_3 \dots$  tangential angles, which of the successive chords make with respective tangents.  $\Delta_1, \Delta_2, \Delta_3 \dots$  be deflection angles.

$$\begin{aligned}\angle VA_1A &= \angle A_1T_1A + \angle A_1AT_1 = \delta_1 + \delta_1 \\ &= 2\delta_1\end{aligned}$$

From the property of circular curve,

$$\angle T_1OA = \angle VA_1A = 2\delta_1$$

$$\begin{aligned} \therefore \text{Chord length} &= C_1 = R \times 2\delta_1, \text{ if } \delta_1 \text{ is in radians} \\ &= R \times 2\delta_1 \times \frac{\pi}{180}, \text{ if } \delta_1 \text{ is in degrees.} \end{aligned}$$

$$\begin{aligned} \therefore \delta_1 &= \frac{C_1}{2R} \times \frac{180}{\pi} \text{ degrees} \\ &= \frac{C_1}{2R} \times \frac{180}{\pi} \times 60 \text{ minutes} \\ &= 1718.87 \frac{C_1}{R} \text{ minutes} \end{aligned}$$

Similarly, 
$$\delta_2 = 1718.87 \frac{C_2}{R} \text{ minutes}$$

From Fig.

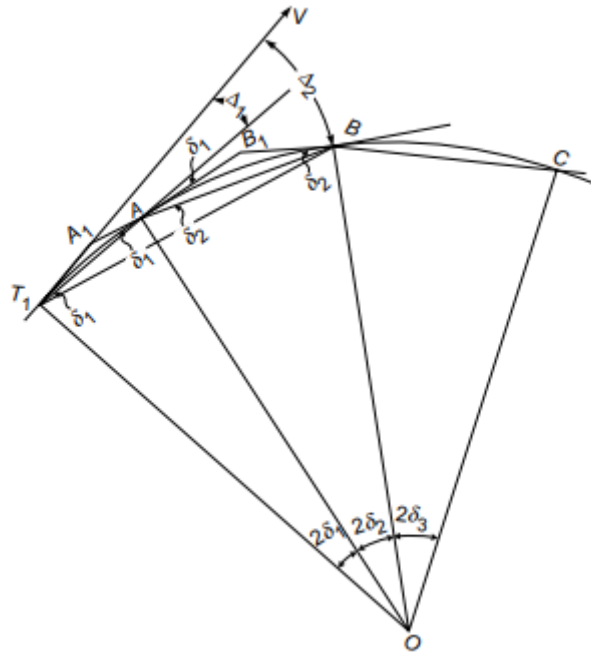

$$\Delta_1 = \text{Deflection angle of } AB = \delta_1$$

For the second chord

$$\Delta_2 = VT_1B = \Delta_1 + \delta_2 = \delta_1 + \delta_2$$

Similarly,

$$\Delta_n = \delta_1 + \delta_2 + \delta_3 + \dots + \delta_n = \Delta_{n-1} + \delta_n$$

Thus, the deflection angle of any chord is equal to the deflection angle for the previous chord plus the tangential angle of that chord.

Note that if the degree of curve is  $D$  for standard length  $s$ ,

$$s = RD \times \frac{\pi}{180} \quad \text{or} \quad R = \frac{s}{D} \times \frac{180}{\pi} \quad \dots(2.20)$$

If the degree of a curve is given, from equations (2.19) and (2.20) deflection angles can be found. Setting the theodolite at point of curve ( $T_1$ ), deflection angle  $\Delta_1$  is set and chord length  $C_1$  is measured along this line to locate  $A$ . Then deflection angle  $\Delta_2$  is set and  $B$  is located by setting  $AB = C_2$ . The procedure is continued to lay the full curve.

### Obstacles in Setting out Simple Circular Curve :

Obstacles in setting out of curves may be classified as due to inaccessibility, due to non-visibility and/or obstacles to chaining of some of the points.

#### Inaccessibility of Points:

This type of obstacles can be further classified as inaccessibility of:

- Point of Intersection (PI)
- Point of Curve (PC)
- Point of Tangency (PT)
- Point of Curve and Point of Intersection (PC and PI).
- Point of Curve and Point of Tangency (PC and PT).

**Point of Intersection is Inaccessible:** It so commonly happens that the intersection point (B) becomes inaccessible due to obstacle like lake, river or wood etc.

Let AB and BC be the two tangents intersection at the point B, and  $T_1$  and  $T_2$  the tangent points. Since the intersections point (B) is used for measuring the deflection angle ( $\phi$ ) and also for locating the tangent points  $T_1$  and  $T_2$ , the field-work be arranged to measure  $\phi$  and to locate  $T_1$  and  $T_2$  without going at B.

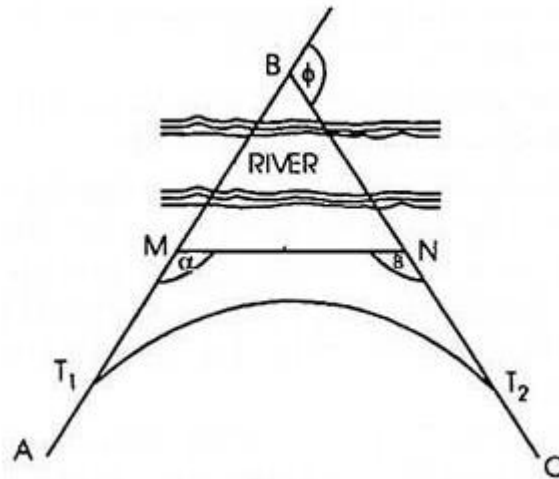

Fig: Point of Intersection is Inaccessible

#### Producers:

- Select two indivisible points M and N suitably on the tangents AB and BC respectively and measure MN accurately.
- Measure the angles AMN ( $\alpha$ ) and CNM ( $\beta$ ) by setting the theodolite at M and N respectively.

Now in  $\Delta BMN$ ,

$$\angle BMN = 180^\circ - \alpha$$

$$\angle BNM = 180^\circ - \beta$$

The deflection angle ( $\phi$ ) =  $\angle BMN + \angle BNM$

$$= (180^\circ - \alpha) + (180^\circ - \beta)$$

$$= 360^\circ - (\alpha + \beta)$$

- Solve the  $\Delta BMN$  by the sine rule for the distance BM and BN.

$$\frac{BM}{\sin \angle BNM} = \frac{BN}{\sin \angle BMN} = \frac{MN}{\sin \angle MBN}$$

(iv) Calculate the tangent lengths  $BT_1 = BT_2 = R \tan \phi/2$

(v) Now the distance  $MT_1 = BT_1 - BM$  and  $NT_2 = BT_2 - BN$

(vi) Measure the distance  $MT_1$  from M along BA, thus locating the first tangent point  $T_1$ . Similarly locate  $T_2$  by measuring  $NT_2$  from N along BC.

When a clear line MN is not available, a traverse is run between M and N to find the length and bearing of the line MN. Then from the known bearings of the tangents and the calculated bearing of the line MN, calculate the angles  $\alpha$  and  $\beta$  and proceed as above.



## BASICS ON SCALE AND BASICS OF MAP

A **map** is almost universally a two-dimensional representation of a piece of three-dimensional space. Only with the advent of modern computer graphics were three-dimensional maps made possible. Maps serve two map functions; they are a spatial database and a communication device. The science of making maps is called **cartography**.

Basic map characteristics tell the reader where an object is (location) and what the object is (its attributes). Maps are also simplified reductions and abstractions of selected real world areas that have attributes of scale, resolution, and are defined onto a projection that distorts the curved surface of the earth onto a flat surface. Different objects represented on the map are classified and symbolized so that the map user can easily use the map as a database of geographic information.

Every map has a scale, determining how large objects on the map are in relation to their actual size. A larger scale shows more detail, thus requiring a larger map to show the same area (a smaller number after the colon means a larger scale: 1:10,000 is a larger scale than 1:25,000).

Map scale refers to the relationship (or ratio) between distance on a map and the corresponding distance on the ground. For example, on a 1:100000 scale map, 1cm on the map equals 1km on the ground.

Map scale is often confused or interpreted incorrectly, perhaps because the smaller the map scale, the larger the reference number and vice versa. For example, a 1:100000 scale map is considered a larger scale than a 1:250000 scale map.

Naturally it is impossible for real world features to be drawn on the map as large as their true size. Therefore in order to represent the real world, maps are made to a specific scale. Map scale is defined as the ratio of the distance between two points on the map to the corresponding distance on the ground. Maps come in a variety of scales. **Large scale maps** cover a small area with great detail and accuracy, while **small scale maps** cover a large area in less detail.

As shown in this image, map scales can be expressed as a verbal statement, as a fraction or ratio and finally as a graphic or bar scale. Such scale expressions can be used to find the ground distance between any features from conversion of the corresponding map distance measurement.



### **Verbal Scale:**

"1 centimetre on the map represents 500m on the ground" is a verbal scale. Clearly here a distance of 1cm on the map corresponds to 500m on the earth's surface. So if you plan a route with a total distance of 22cm on the map, that would imply that you'll be traveling  $(22\text{cm} \times 500\text{m}) / 1\text{cm} = 11000\text{m}$  or 11km on the ground.

### **Representative Fraction (RF) - Fractional Scale - Ratio Scale:**

1:50000 represents the map scale as a mathematical ratio or fraction, thus the name *ratio scale* or *fractional scale*. 1:50000 can be shown as  $1/50000$  as well. Here such a scale means that one unit of measurement on the map is equal to 50000 of the same unit on the ground. Such a unit can be anything such as centimetre, meter, feet, inches, your finger length, half a length of a pencil, etc. Also we can say that any distance on the map is  $1/50000$  of its true value on the ground. Therefore 1cm on the map is equal to 50000cm on the ground, that is 1cm on the map is equal to  $(50000\text{cm} \times 1\text{m}) / 100\text{cm} = 500\text{m}$  or 0.5km on the ground. Again a 22cm route on the map can be calculated to be equal  $22 \times 50000\text{cm} = 1100000\text{cm}$  on the ground or  $(1100000\text{cm} \times 1\text{m}) / 100\text{cm} = 11000\text{m}$ .

### **Bar Scale - Graphic Scale - Linear Scale:**

Bar scale also known as scale bar, linear scale or graphical scale visually shows the relationship between distances on the map and the real world. Usually more than one bar scale is shown on the side of the map, each using a different unit of measurement. To measure distance on Google Maps you can use the bar scale found on the corner of the map. The scale length and numbers get adjusted as the map is zoomed in or out. To see an example of measuring distances using bar scale, check the slope calculation from contour lines section.

Knowing the fractional scale of a map, an engineer's or architect's scale ruler can be used to find the ground distances directly without the above mathematical calculations. The rulers can be found in both metric and English units of measurement. Many compasses have a similar scale ruler on their base plate. Finding distances of meandering features such as trails or rivers can be challenging and time consuming using a straight-edged object such as a ruler; in such cases you can use a string and place it on the map along the length of the feature, then place the string beside the bar scale for a direct measurement (or measure the length of it with a ruler).

### **Small Scale vs. Large Scale Maps**

As mentioned above maps come in variety of scales. Large or small scale maps can be distinguished by the use of fractional or ratio expressions. A map covering a large area (e.g. country or state) with a small scale fraction is a small scale map (e.g. 1:1000000), whereas a map covering a smaller area (town) with a large scale fraction is a large scale map (e.g. 1:10000). Most times the comparison of large scale and small scale maps can be relative. For example a 1:250000 map is smaller scale than a 1:50000 map. When confused, just carry

out the division:  $1/250000 < 1/50000$ ; larger denominator results in a smaller number. The smaller scale the topo map is, there will be less detail with more generalization, and the harder it will be to detect terrain features. Therefore a map at a scale of 1:250000 while adequate for bike touring and car camping will not be useful for hiking or mountaineering trip planning

When dealing with digital maps, it is normal for the map to be resized during printing in order for it to fit the page. A digital map's size might also get altered by saving it to another format (e.g. jpg, png, pdf). The same problem applies when a hard copy map is reproduced by photocopying. Note that in such situations the original ratio scale (or verbal scale) of the map would not be accurate anymore. However the advantage of bar scale is that it would shrink or expand consistently with the map in case of any resizing, and therefore will remain an accurate representation of the map scale. Also differing monitor resolutions and zoom levels make ratio/verbal scales for digital maps unreliable.

Another point worth considering is that while you can view a digital map at any scale by zooming in/out on the computer screen, you should note that when a map is produced at a certain scale with a certain level of accuracy (or level of error), changing its scale would not affect the original level of accuracy. For example when zooming in a 1:50000 topographic map so that its scale changes to 1:25000 or 1:10000, the level of accuracy of the map will remain at the original level designed for the 1:50000 map. In other words your zoomed in map (to 1:10000 scale) would not possess the same level of accuracy as an originally published 1:10000 map.

## **MAP PROJECTION**

Map projection is the method of transferring the graticule of latitude and longitude on a plane surface. It can also be defined as the transformation of spherical network of parallels and meridians on a plane surface. As you know that, the earth on which we live in is not flat. It is geoid in shape like a sphere. A globe is the best model of the earth. Due to this property of the globe, the shape and sizes of the continents and oceans are accurately shown on it. It also shows the directions and distances very accurately. The globe is divided into various segments by the lines of latitude and longitude. The horizontal lines represent the parallels of latitude and the vertical lines represent the meridians of the longitude. The network of parallels and meridians is called graticule. This network facilitates drawing of maps. Drawing of the graticule on a flat surface is called projection.

But a globe has many limitations. It is expensive. It can neither be carried everywhere easily nor can a minor detail be shown on it. Besides, on the globe the meridians are semi-circles and the parallels are circles. When they are transferred on a plane surface, they become intersecting straight lines or curved lines.

## **NEED FOR MAP PROJECTION**

The need for a map projection mainly arises to have a detailed study of a region, which is not possible to do from a globe. Similarly, it is not easy to compare two natural regions on a globe. Therefore, drawing accurate large-scale

maps on a flat paper is required. Now, the problem is how to transfer these lines of latitude and longitude on a flat sheet. If we stick a flat paper over the globe, it will not coincide with it over a large surface without being distorted. If we throw light from the centre of the globe, we get a distorted picture of the globe in those parts of paper away from the line or point over which it touches the globe. The distortion increases with increase in distance from the tangential point. So, tracing all the properties like shape, size and directions, etc. from a globe is nearly impossible because the globe is not a developable surface.

In map projection we try to represent a good model of any part of the earth in its true shape and dimension. But distortion in some form or the other is inevitable. To avoid this distortion, various methods have been devised and many types of projections are drawn. Due to this reason, map projection is also defined as the study of different methods which have been tried for transferring the lines of graticule from the globe to a flat sheet of paper.

### **ELEMENTS OF MAP PROJECTION**

- a. Reduced Earth:** A model of the earth is represented by the help of a reduced scale on a flat sheet of paper. This model is called the “reduced earth”. This model should be more or less spheroid having the length of polar diameter lesser than equatorial and on this model the network of graticule can be transferred.
- b. Parallels of Latitude:** These are the circles running round the globe parallel to the equator and maintaining uniform distance from the poles. Each parallel lies wholly in its plane which is at right angle to the axis of the earth. They are not of equal length. They range from a point at each pole to the circumference of the globe at the equator. They are demarcated as  $0^{\circ}$  to  $90^{\circ}$  North and South latitudes.
- c. Meridians of Longitude:** These are semi-circles drawn in north-south direction from one pole to the other, and the two opposite meridians make a complete circle, i.e. circumference of the globe. Each meridian lies wholly in its plane, but all intersect at right angle along the axis of the globe. There is no obvious central meridian but for convenience, an arbitrary choice is made, namely the meridian of Greenwich, which is demarcated as  $0^{\circ}$  longitudes. It is used as reference longitudes to draw all other longitudes.
- d. Global Property:** In preparing a map projection the following basic properties of the global surface are to be preserved by using one or the other methods: (i) Distance between any given points of a region; (ii) Shape of the region; (iii) Size or area of the region in accuracy; (iv) Direction of any one point of the region bearing to another point.

### **How Maps Convey Location and Extent ?**

A map is a collection of map elements laid out and organized on a page. Common map elements include the map frame with map layers, a scale bar, north arrow, title, descriptive text, and a symbol legend.

The primary map element is the map frame, and it provides the principal display of geographic information. Within the map frame, geographical entities are presented as a series of map layers that cover a given map extent—for example, map layers such as roads, rivers, place names, buildings, political boundaries, surface elevation, and satellite imagery.

The following graphic illustrates how geographical elements are portrayed in maps through a series of map layers. Map symbols and text are used to describe the individual geographic elements.

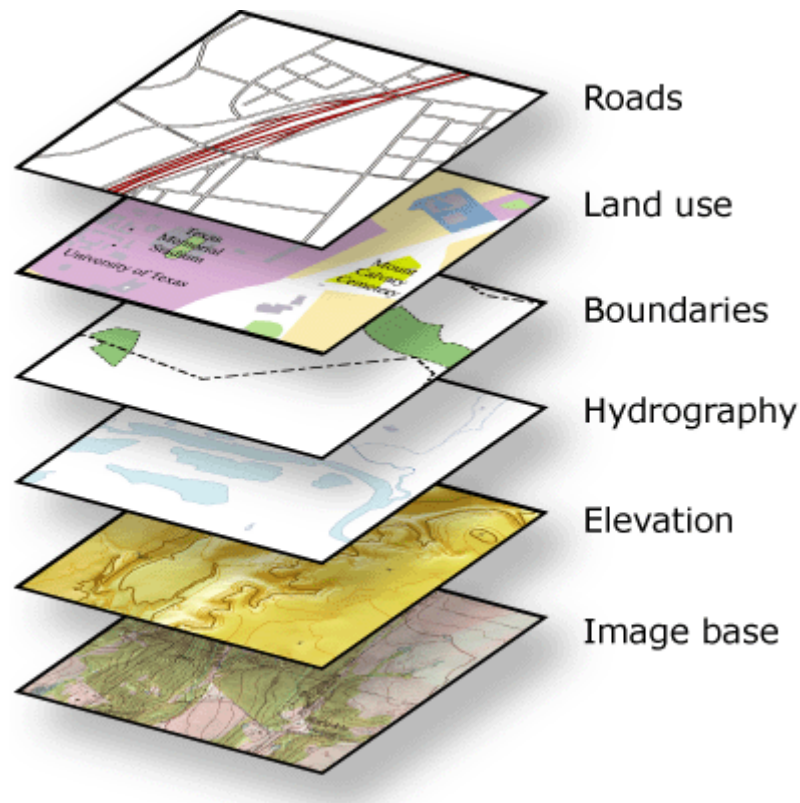

Map layers are thematic representations of geographic information, such as transportation, water, and elevation. Map layers help convey information through:

- Discrete features such as collections of points, lines, and polygons
- Map symbols, colors, and labels that help to describe the objects in the map
- Aerial photography or satellite imagery that covers the map extent
- Continuous surfaces such as elevation which can be represented in a number of ways—for example, as a collection of contour lines and elevation points or as shaded relief

### **Map Layout and composition**

Along with the map frame, a map presents an integrated series of map elements laid out and arranged on a page. Common map elements include a north arrow, a scale bar, a symbol legend, and other graphical elements. These elements aid in map reading and interpretation.

The map layout below illustrates how map elements are arranged on a page.

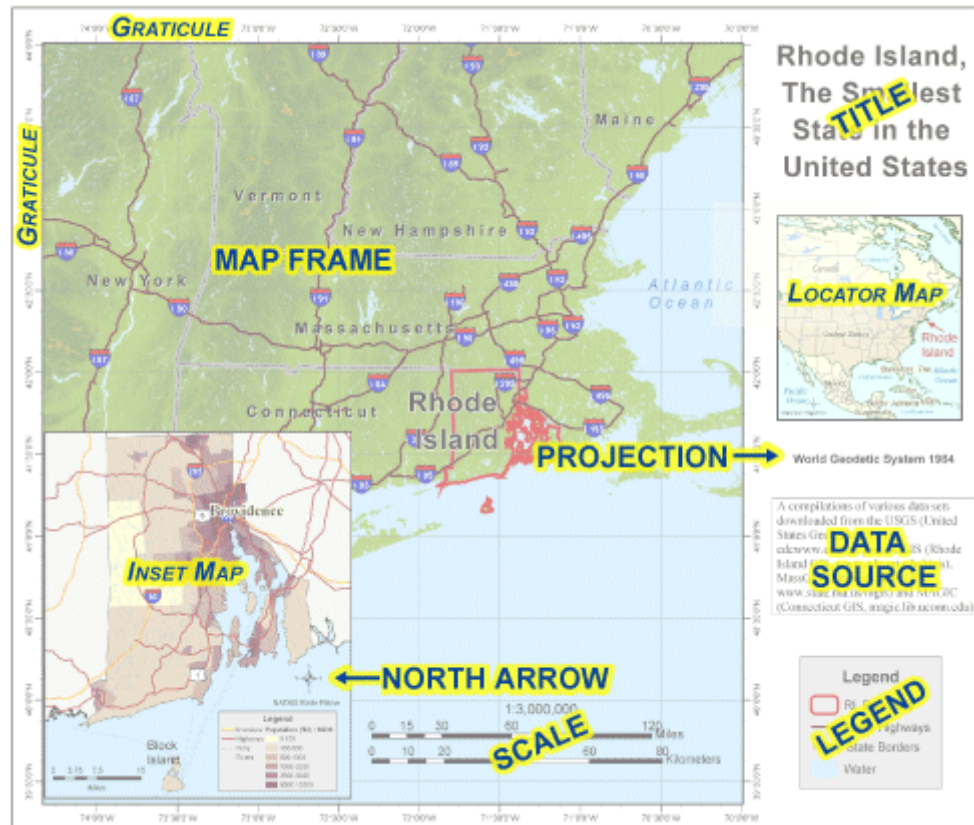

Often, maps include additional elements such as graphs, charts, pictures, and text that help to communicate additional critical information.

### Spatial relationships in a map:

Maps help convey geographic relationships that can be interpreted and analyzed by map readers. Relationships that are based on location are referred to as spatial relationships. Here are some examples.

- Which geographic features *connect* to others (for example, Water Street connects with 18th Ave.)
- Which geographic features are *adjacent* (contiguous) to others (for example, The city park is adjacent to the university.)
- Which geographic features are *contained within* an area (for example, The building footprints are contained within the parcel boundary.)
- Which geographic features *overlap* (for example, The railway crosses the freeway.)
- Which geographic features are *near* others (proximity) (for example, The Courthouse is near the State Capitol.)
- The feature geometry *is equal to* another feature (for example, The city park is equal to the historic site polygon).
- The *difference* in elevation of geographic features (for example, The State Capitol is uphill from the water.)
- The feature is *along* another feature (for example, The bus route follows along the street network.).

Within a map, such relationships are not explicitly represented. Instead, as the map reader, you interpret relationships and derive information from the relative position and shape of the map elements, such as the streets, contours, buildings, lakes, railways, and other features. In a GIS, such relationships can be modeled by applying rich data types and behaviors (for example, topologies and networks) and by applying a comprehensive set of spatial operators to the geographic objects (such as buffer and polygon overlay).

### **Classification of Maps :**

#### **Physical Map :**

The definition of a physical map is a depiction of the geographic features of an area.

- All bodies or occurrences of water are marked on the map in one colour and the map shows whether they are streams, rivers, lakes or larger bodies of water.
- Mountains, deserts and plains all have their own unique colour and designations.
- A topological style of physical map shows the terrain covered on the map as a 3-dimensional representation.



PHYSICAL MAP OF  
INDIA 1st edn 2011 4

#### **Topographic Map**

Topographic maps are detailed, accurate graphic representations of features that appear on the Earth's surface. These features include:

- ❖ **Cultural:** roads, buildings, urban development, railways, airports, names of places and geographic features, administrative boundaries, state and international borders, reserves
- ❖ **Hydrography:** lakes, rivers, streams, swamps, coastal flats
- ❖ **Relief:** mountains, valleys, contours and cliffs, depressions
- ❖ **Vegetation:** wooded and cleared areas, vineyards and orchards.

Topographic maps usually show a geographic graticule and a coordinate grid, so you can determine relative and absolute positions of mapped features.

#### **Road Map**

A map with a visual representation of roads used for automobile travel and navigation. A road map may contain other relevant data, such as terrain or rail roads.

It shows major, some minor highways and roads, airports, railroad tracks, cities and other points of interest in an area. People use road maps to plan trips and for driving directions.



ROAD MAP OF INDIA  
9th edn 2011 2\_5M.p

## **Political map**

Political maps are designed to show governmental boundaries of countries, states, and counties, the location of major cities, and they usually include significant bodies of water. Like the sample above, differing colours are often used to help the user differentiate between nations.

A political map shows the government borders for countries, states and counties, as well as the location of capitals and major cities.

- ❖ Political maps are most often flat and denote country borders in bright colours to help identify the edges of countries.
- ❖ Depending on the scale of the map, political maps may also include highways, roads and cities.
- ❖ Political maps are also used to demark borders to aid people and organizations with giving money and food to the needy.

<http://www.surveyofindia.gov.in/files/Political%20Map%20of%20India.jpg>

## **Economic & Resources Map**

An economic or resource map shows the specific type of economic activity or natural resources present in an area through the use of different symbols or colours depending on what is being shown on the map. These maps are very helpful in finding out where companies should mine and search for particular resources.

An economic or a resource map is a map that outlines the kind of economic activities that take place in a certain region. This kind of map features a variety of colours and symbols that refer to specific economic activities. Economic maps often present natural resources and labour resources as part of an area's economy.

The first economic maps were seen in what is now Russia in the 1600s and were drawn by hand. The publishing of the first printed maps took place in the 1840s. General economic maps serve to outline entire economies. These maps portray a larger area, complete with its economic regions, economic ties, specialization of productions, territorial-production complexes, economic centers, and levels of economic development.

The center of interest of an economic map could be on anything from agriculture, manufacturing, mining, and other economic activities of a region. Shading or colour indicates the land location devoted to particular activities such as farming. Symbols indicate the varieties of natural resources in the region. They frequently show highways, roads, and shipping ports.

An economic map can help manufacturers save time and money with production. Economic maps help in identifying the commodities necessary for production in a region and in determining whether there is a stable availability of raw materials around. They also help to track the leading producers of goods. Economic maps can be used to ease preparation, predicting developments and identifying productive forces.

Economic maps are useful in making better decisions by giving better knowledge into a place and distribution of one's resources. With a resource map, individuals or group of individuals can cooperatively record, track, and



examine resources at a quick look using a live map. It can show people what sort of money places have, or the number of employees in a certain area. Hence, they are used for informing people on economic status or levels.

<https://www.vox.com/2014/8/26/6063749/38-maps-that-explain-the-global-economy>

## **Thematic Map**

A **thematic map** is a type of map specifically designed to show a particular theme connected with a specific geographic area, such as temperature variation, rainfall distribution or population density.

A **thematic map** is a specialized map made to visualize a particular subject or theme about a geographic area. Thematic maps can portray physical, social, political, cultural, economic, sociological, or any other aspects of a city, state, region, nation, continent, or the entire globe. A thematic map is designed to serve a special purpose or to illustrate a particular subject, in contrast to a general map, on which a variety of phenomena appear together, such as landforms, lines of transportation, settlements, and political boundaries.<sup>[2]</sup> This is in direct contrast to a reference map or Topographic map, which are designed to show the location of visible features of the landscape with minimal interpretation and intended to be used for a wide variety of purposes. Thematic maps also portray basic features such as coastlines, boundaries and places, but they are only used as a point of locational reference for the phenomenon being mapped.

Thematic maps also emphasize spatial variation of one or a number of geographic distributions. These distributions may be physical phenomena such as climate or human characteristics such as population density and health issues.

Barbara Petchenik described the difference as "in place, about space." While general reference maps show where something is in space, thematic maps tell a story about that place based on spatial patterns. Thematic maps are sometimes referred to as graphic essays because they display spatial variations and interrelationships of geographical distributions that can be interpreted.

A thematic map will typically consist of three types of information:

1. **Primary theme:** the geographic phenomena that represent the topic being discussed. In a map of population density of a city, this would be population density. Most thematic maps have a single primary theme. Multivariate maps are also possible but are typically more difficult to design well.
2. **Supporting theme:** a layer of information that helps to tell the story, such as those that offer possible explanations for the patterns found in the primary theme. For a city population density map, this could be population attractors such as shopping districts or highways, or exclusionary features such as water bodies or mountains.
3. **Reference theme:** a layer of geographic features that usually have little to do with the theme of the map, but help map readers locate the thematic

information in a context of recognizable geography. Roads, administrative boundaries, terrain, and latitude/longitude reticules are common reference layers.

Because these are in a clear conceptual order of importance to map readers (primary theme most important, reference least important), a well-designed thematic map should reflect this order in the visual hierarchy.



Thematic Map.pdf

## Climate Map

A map is a graphic representation of a feature on the earth's surface. There are several types of maps including thematic maps, topographic maps, road maps, and climate maps among other maps. A climate map is a graphical representation of the distribution of the prevailing weather patterns in a given area that has been observed over a long period. The map can represent an individual climatic variable or a combination of all the variable. A climate map provides an overview of the climatic features over a large region and allows for the comparison of the climatic features in different regions. It can represent the climate of a country, region, continent, or the entire globe. The maps also help scientists track and illustrate climate change in different regions.

The information presented on a climate map often applies to individual months or averages over the entire year. The map represents information that has been gathered over a period that can stretch over decades. The various climate classification systems can be used to produce a world climate map. Specific seasons can also be illustrated on the map. There are two main types of climate maps: temperature maps and precipitation maps. Temperature maps represent the average monthly temperature of a particular area over a period of time while precipitation map show distribution of precipitation variable such as rainfall and snowfall in a given area. Apart from indicating the climatic pattern of an area, climate maps are also be used to predict the future effects of climate change and possible effect of global warming.

Climate maps are overlaid with colours representing the different climatic zones. There are no standard or specific colour for each climate zone as long as different colours are used to differentiate climate zones within the same area. In addition to colours, letter codes are also used to specify differences among zones. Isolines are drawn on the maps to connect points with equal long term mean values of a climatic variable (temperature, atmospheric pressure, and humidity). Isobars are used for pressure, isohyets for precipitation, and isotherm for temperature.



Fig. Map of Climatic Region in India

# **SURVEY OF INDIA MAP SERIES**

## **NATIONAL MAP POLICY - 2005**

### **PREAMBLE**

All socio-economic developmental activities, conservation of natural resources, planning for disaster mitigation and infrastructure development require high quality spatial data. The advancements in digital technologies have now made it possible to use diverse spatial databases in an integrated manner. The responsibility for producing, maintaining and disseminating the topographic map database of the whole country, which is the foundation of all spatial data vests with the Survey of India (SOI). Recently, SOI has been mandated to take a leadership role in liberalizing access of spatial data to user groups without jeopardizing national security. To perform this role, the policy on dissemination of maps and spatial data needs to be clearly stated.

### **OBJECTIVES**

- To provide, maintain and allow access and make available the National Topographic Database (NTDB) of the SOI conforming to national standards.
- To promote the use of geospatial knowledge and intelligence through partnerships and other mechanisms by all sections of the society and work towards knowledgebased society.

### **TWO SERIES OF MAPS**

To ensure that in the furtherance of this policy, national security objectives are fully safeguarded, it has been decided that there will be two series of maps namely

- (a) **Defence Series Maps (DSMs)**- These will be the topographical maps (on Everest/WGS-84 Datum and Polyconic/UTM Projection) on various scales (with heights, contours and full content without dilution of accuracy). These will mainly cater for defence and national security requirements. This series of maps (in analogue or digital forms) for the entire country will be classified, as appropriate, and the guidelines regarding their use will be formulated by the Ministry of Defence.
- (b) **Open Series Maps (OSMs)** – OSMs will be brought out exclusively by SOI, primarily for supporting development activities in the country. OSMs shall bear different map sheet numbers and will be in UTM Projection on WGS-84 datum. Each of these OSMs (in both hard copy and digital form) will become “Unrestricted” after obtaining a one-time clearance of the Ministry of Defence. The content of the OSMs will be as given in Annexure ‘B’. SOI will ensure that no civil and military Vulnerable Areas and Vulnerable Points (VA’s/VP’s) are shown on OSMs.

The SOI will issue from time to time detailed guidelines regarding all aspects of the OSMs like procedure for access by user agencies, further dissemination/sharing of OSMs amongst user agencies with or without value additions, ways and means of protecting business and commercial interests of

SOI in the data and other incidental matters. Users will be allowed to publish maps on hard copy and web with or without GIS database. However, if the international boundary is depicted on the map, certification by SOI will be necessary. In addition, the SOI is currently preparing City Maps. These City Maps will be on large scales in WGS-84 datum and in public domain. The contents of such maps will be decided by the SOI in consultation with Ministry of Defence.

### **NATIONAL TOPOGRAPHICAL DATA BASE (NTDB)**

SOI will continue to create, develop and maintain the National Topographical Data Base (NTDB) in analogue and digital forms consisting of following data sets:

- a. National Spatial Reference Frame,
- b. National Digital Elevation Model,
- c. National Topographical Template,
- d. Administrative Boundaries, and
- e. Toponymy (place names).

Both the DSMs and OSMs will be derived from the NTDB.

### **MAP DISSEMINATION AND USAGE**

Open Series Maps of scales larger than 1:1 million either in analogue or digital formats can be disseminated by SOI by sale or through an agreement to any agency for specific end use. This transaction will be registered in the Registration database with details of the receiving agency, end use etc.

- Through the agreement, SOI will allow a user to add value to the maps obtained (either in analogue or digital formats) and prepare his own value-added maps.
- The user should be able to share these maps with others – the information of all such sharing will also require to be logged in the Map Transaction Registry.

### **APPLICABILITY OF PREVIOUS INSTRUCTIONS:**

The Ministry of Defence has from time to time issued detailed guidelines on various aspects of map access and use. These instructions shall continue to hold good but for the modifications cited herein.

# शीटों का विन्यास LAYOUT OF SHEETS

अनुबंध 'क'  
Annexure 'A'

आधार : विश्व ज्योडीय पद्धति - 84  
DATUM: WORLD GEODETIC SYSTEM (WGS)- 84

प्रक्षेप : यूनिवर्सल ट्रान्सवर्स मर्केटर  
PROJECTION : UNIVERSAL TRANSVERSE MERCATOR (UTM)

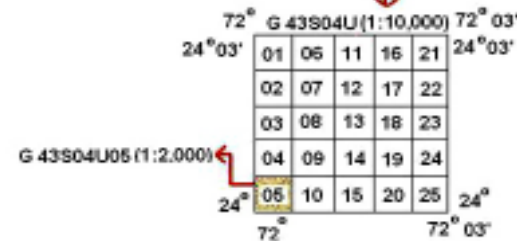
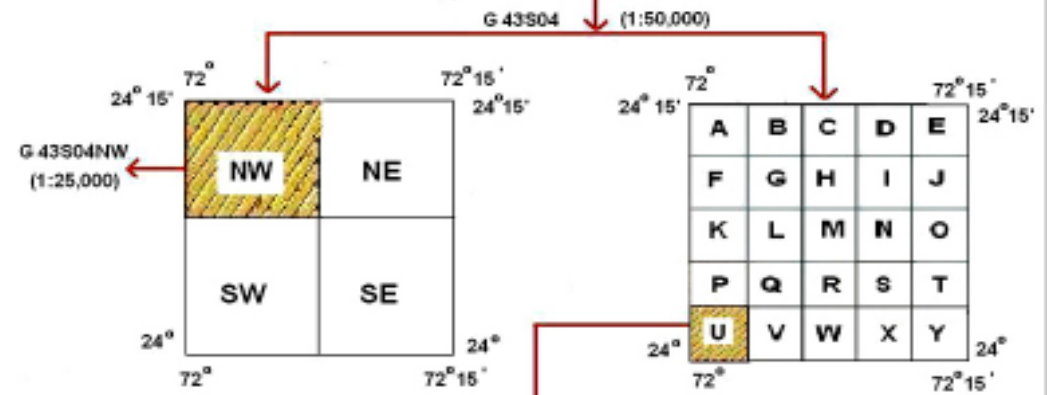
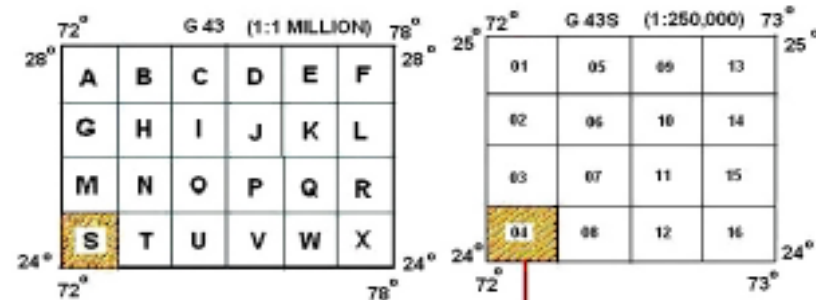
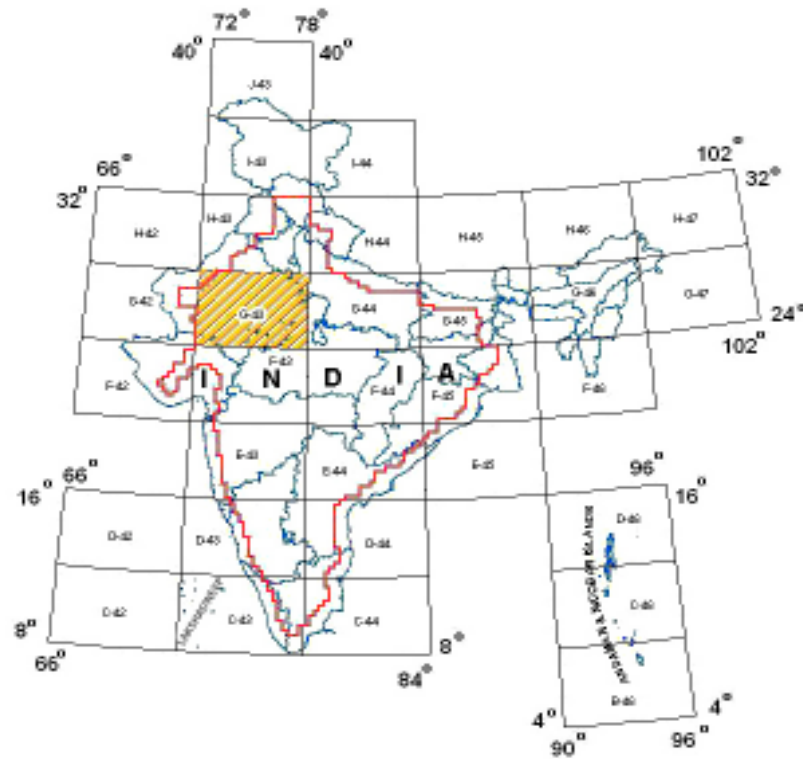

## CONTENTS OF OSM

Annexure 'B'

SL.NO.	CATEGORY/LAYER		SUB DETAILS
1.	GENERAL		Latitude/Longitude Name of State/District/Administrative index Topo sheet Number/Year of Survey/Edition No./Index to topo sheets Magnetic variation from true North direction Map reference Bar scale/Representative Factor
2.	ADMINISTRATIVE BOUNDARIES	Names Boundary Boundary Pillars	Administrative/Locality or tribal International to village, Forest, all boundary pillars, village trijunctions
3.	COMMUNICATIONS/ROADS	Roads Tracks Railways Embankments Other Lines	All Roads All Tracks, pass, footpath All gauges with stations, tunnels Light railways or tramway, All embankments, Road/rail/tank
4.	HYDROLOGY	Stream/Canals Dams Rivers & Banks Wells, Water Features	All streams/canals All earthwork dams All rivers with details, banks, islands All wells/tube wells/springs All Tanks (excluding overhead tanks), Lightship, buoys, anchorages
5.	SETTLEMENT/CULTURAL DETAILS	Towns or Villages Offices Settlements	Village inhabited, deserted and forts Huts, Tower, Antiquities Religious places, tombs/grave All post/telegraphic/Police stations hut All Bungalows
6.	TRANSMISSION LINE		
7.	RELIEF/HYPSOGRAPHY	Contours Sand Features Ice Forms Heights Benchmarks	Contours with sub features All sand features Ice forms (all features) Spot height, Approximate height Bench marks (Geodetic tertiary, canal)
8.	VEGETATION	Plantations, Trees	All trees, Vine on trellis, grass, scrub.
9.	FOREST		Reserved/Protected

\* Contours & heights will not be available in restricted zones as per MOD's instructions.

## Map Nomenclature

In India Topographic maps produced by Survey of India (SOI) offer detailed information on a particular area and are used for several types of activities such as emergency preparedness, urban planning, resource development and surveying to camping, canoeing, adventure racing, hunting and fishing. This guide will help the user understand the basics of topographic maps.

The guide provides an overview of mapping concepts, along with tips on how to use a topographic map, explanations of technical terminology and examples of symbols used to represent topographic features on topographic maps.

**Why?** Topographic maps represent the Earth's features accurately and to scale on a two dimensional surface. Topographic maps are an excellent planning tool and guide and, at the same time, help make outdoor adventures enjoyable and safe.

**What is a topographic map?** A topographic map is a detailed and accurate illustration of man-made and natural features on the ground such as roads, railways, power transmission lines, contours, elevations, rivers, lakes and geographical names. The topographic map is a two-dimensional representation of the Earth's three-dimensional landscape.

**What information is on a topographic map?** Topographic maps identify numerous ground features, which can be grouped into the following categories:

**Relief:** mountains, valleys, slopes, depressions as defined by contours

**Hydrography:** lakes, rivers, streams, swamps, rapids, falls

**Vegetation:** wooded areas.

**Transportation:** roads, trails, railways, bridges, airports/airfield, seaplane anchorages.

**Culture:** buildings, urban development, power transmission line, pipelines, towers

**Boundaries:** international, provincial/territorial, administrative, recreational, geographical

**Toponymy:** place names, water feature names, landform names, boundary names

Refer to the map legend for a complete listing of all features and their corresponding symbols. Information along the map borders provides valuable details to help you understand and use a topographic map. For example, here you will find the map scale and other important information about the map such as the year, the edition and information pertaining to the map data.

## Quadrangle Name

In geology or geography, the word "**quadrangle**" usually refers to a United States Geological Survey (USGS) 7.5-minute quadrangle map, which are usually named after a local physiographic feature. The shorthand "quad" is also used, especially with the name of the map; for example, "the Ranger Creek, Texas quad map". These maps appear rectangular, hence the use of the word "quadrangle" to describe them. On a USGS 7.5-minute quadrangle map, the north and south limits of the quadrangle are not straight lines, but are actually curved to match Earth's



lines of latitude on the standard projection. The east and west limits are usually not parallel as they match Earth's lines of longitude. In the United States, a 7.5 minute quadrangle map covers an area of 49 to 70 square miles.

As a specific surveying term, a quadrangle is the basic subdivision of the United States Public Land Survey System. In this system, a quadrangle is an area that can be subdivided into 16 townships, and has limits generally measuring 24 miles on each side, although this distance is not exact due to the effects of surveying and mapping the curved surface of Earth.

The surfaces of other planets have also been divided into quadrangles by the USGS. Martian quadrangles are also named after local features.

Quadrangles that lie on the pole of a body are also sometimes called "areas" instead, since they are circular rather than four-sided.

### **Latitude, Longitude, UTM's Grid Mapping**

Using Lat/Long is different from using a street address. Instead of having a specific street address, Lat/Long works with a numbered grid system, like what you see when you look at graph paper. It has horizontal lines and vertical lines that intersect. A location can be mapped or found on a grid system simply by giving two numbers which are the location's horizontal and vertical coordinates; or, to say it another way, the "intersection" where the place is located).

#### **Grid Mapping a Globe:**

Latitude and Longitude lines are a grid map system too. But instead of being straight lines on a flat surface, Lat/Long lines encircle the Earth, either as horizontal circles or vertical half circles.

#### **Latitude**

Horizontal mapping lines on Earth are lines of latitude. They are known as "parallels" of latitude, because they run parallel to the equator. One simple way to visualize this might be to think about having imaginary horizontal "hula hoops" around the earth, with the biggest hoop around the equator, and then progressively smaller ones stacked above and below it to reach the North and South Poles.

Latitude lines are a numerical way to measure how far north or south of the equator a place is located. The equator is the starting point for measuring latitude--that's why it's marked as 0 degrees latitude. The number of latitude degrees will be larger the further away from the equator the place is located, all the way up to 90 degrees latitude at the poles. Latitude locations are given as \_\_ degrees North or \_\_ degrees South.

#### **Longitude**

Vertical mapping lines on Earth are lines of longitude, known as "meridians". One simple way to visualize this might be to think about having hula hoops cut in half, vertically positioned with one end at the North Pole and the other at the South Pole.

Longitude lines are a numerical way to show/measure how far a location is east or west of a universal vertical line called the Prime Meridian. This Prime

Meridian line runs vertically, north and south, right over the British Royal Observatory in Greenwich England, from the North Pole to the South Pole. As the vertical starting point for longitude, the Prime Meridian is numbered 0 degrees longitude.

To measure longitude east or west of the Prime Meridian, there are 180 vertical longitude lines east of the Prime Meridian and 180 vertical longitude lines west of the Prime Meridian, so longitude locations are given as \_\_ degrees east or \_\_ degrees west. The 180 degree line is a single vertical line called the International Date Line, and it is directly opposite of the Prime Meridian.

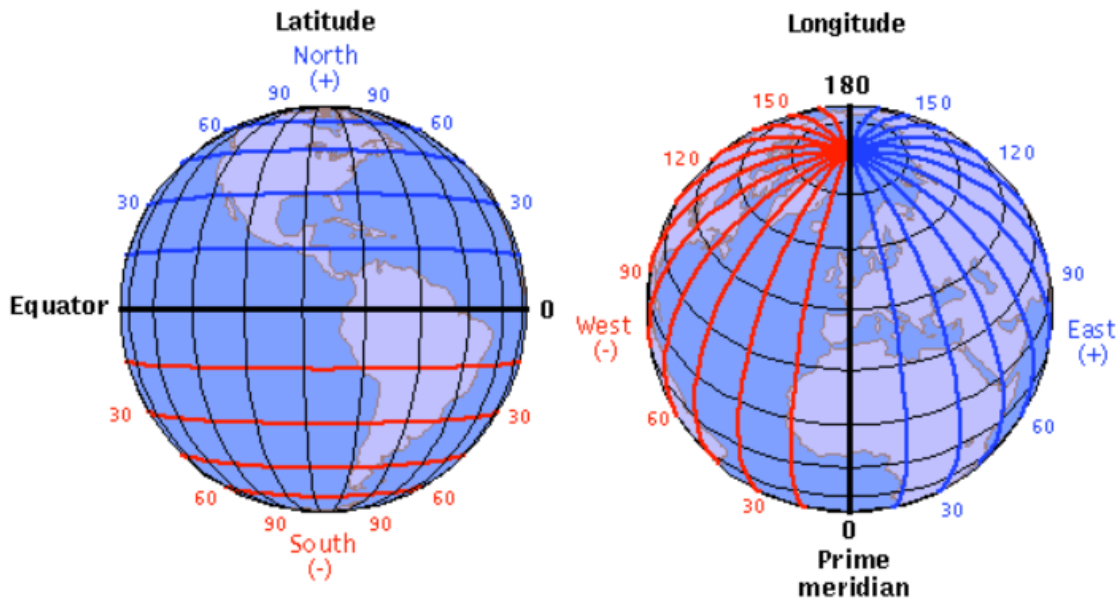

**Fig: Longitude & Latitude**

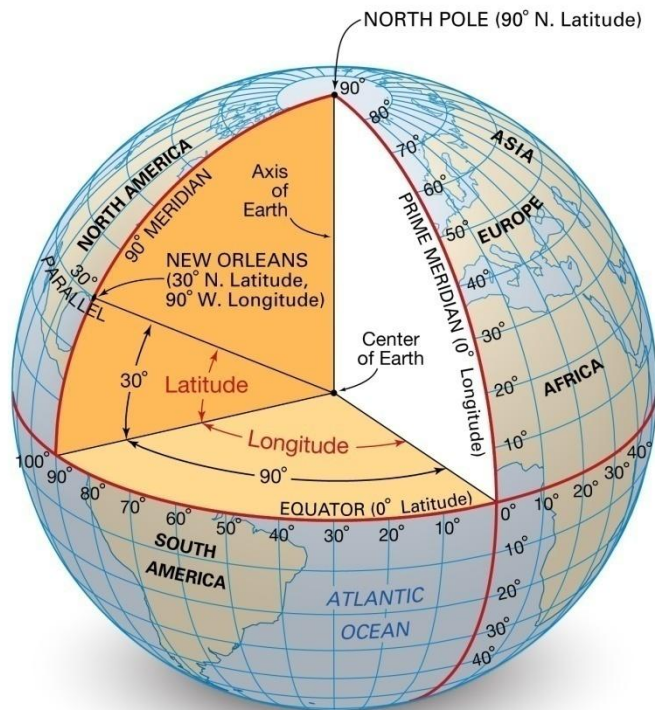

## UTM's

The **Universal Transverse Mercator (UTM)** is a map projection system for assigning coordinates to locations on the surface of the Earth. Like the traditional method of latitude and longitude, it is a horizontal position representation, which means it ignores altitude and treats the earth as a perfect ellipsoid. However, it differs from global latitude/longitude in that it divides earth into 60 zones and projects each to the plane as a basis for its coordinates. Specifying a location means specifying the zone and the  $x$ ,  $y$  coordinate in that plane. The projection from spheroid to a UTM zone is some parameterization of the transverse Mercator projection. The parameters vary by nation or region or mapping system.

Most zones in UTM span 6 degrees of longitude, and each has a designated central meridian. The scale factor at the central meridian is specified to be 0.9996 of true scale for most UTM systems in use.

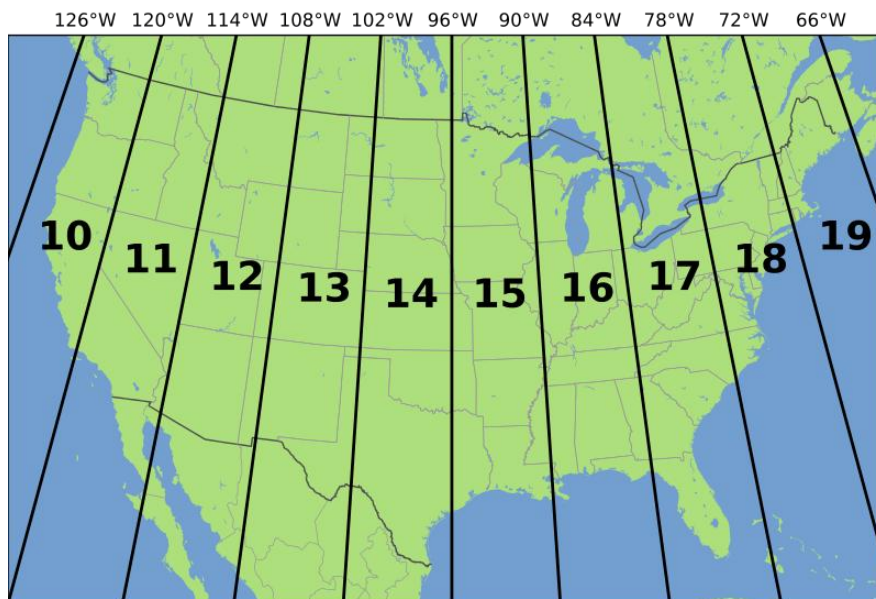

### The Universal Transverse Mercator Grid

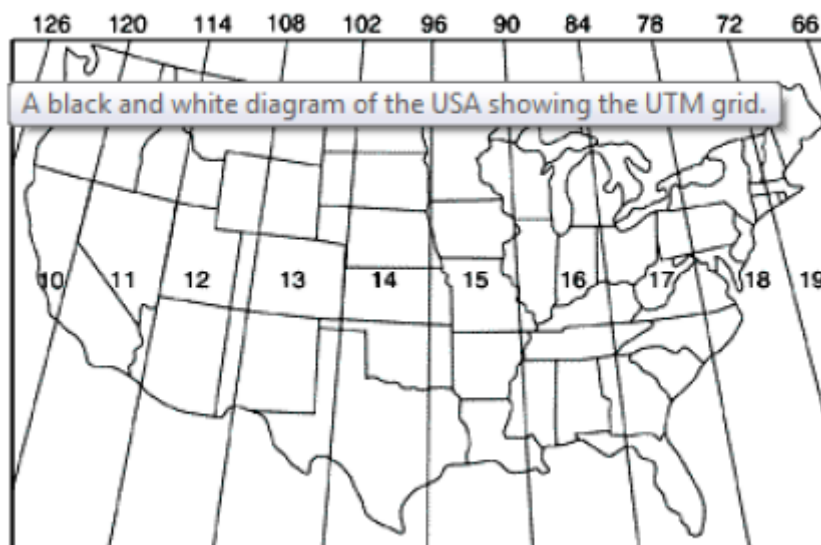

## UTM zone

The UTM system divides the Earth into 60 zones, each 6° of longitude in width. Zone 1 covers longitude 180° to 174° W; zone numbering increases eastward to zone 60, which covers longitude 174°E to 180°. The Polar Regions south of 80°S and north of 84°N are excluded.

Each of the 60 zones uses a transverse Mercator projection that can map a region of large north-south extent with low distortion. By using narrow zones of 6° of longitude (up to 668 km) in width, and reducing the scale factor along the central meridian to 0.9996 (a reduction of 1:2500), the amount of distortion is held below 1 part in 1,000 inside each zone. Distortion of scale increases to 1.0010 at the zone boundaries along the equator.

In each zone the scale factor of the central meridian reduces the diameter of the transverse cylinder to produce a secant projection with two standard lines, or lines of true scale, about 180 km on each side of, and about parallel to, the central meridian ( $\text{Arc cos } 0.9996 = 1.62^\circ$  at the Equator). The scale is less than 1 inside the standard lines and greater than 1 outside them, but the overall distortion is minimized.

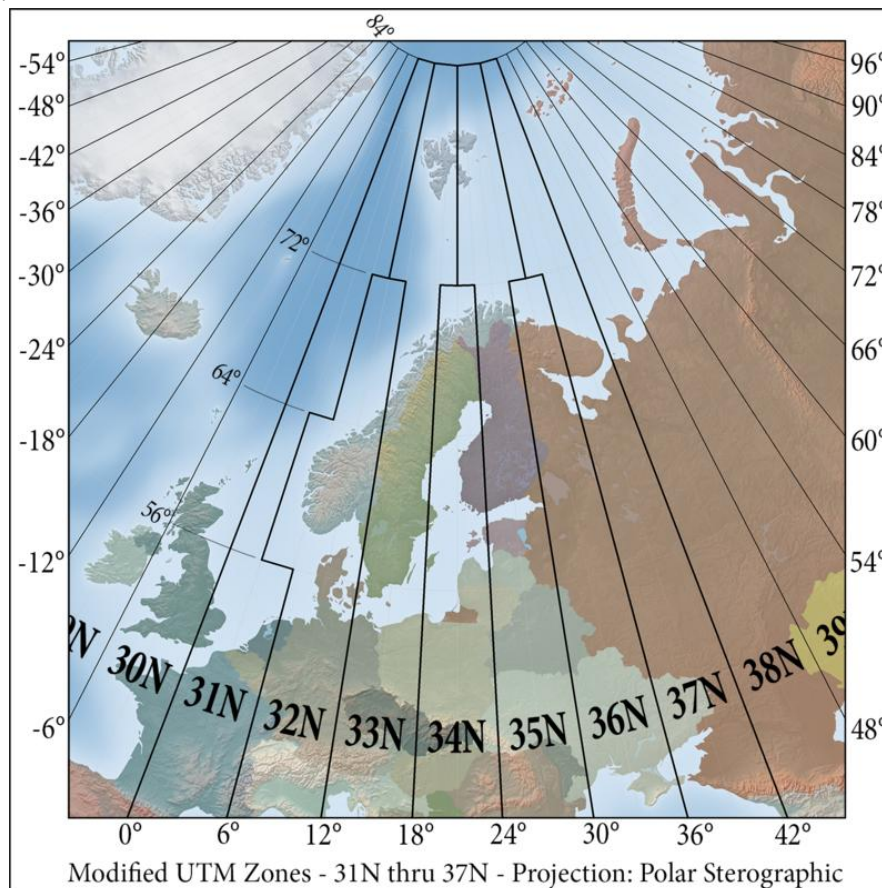

## Contour Lines

A **contour line** (also **isoline**, **isopleth**, or **isarithm**) of a function of two variables is a curve along which the function has a constant value, so that the curve joins points of equal value. It is a plane section of the three-dimensional graph of the function  $f(x, y)$  parallel to the  $(x, y)$ -plane. In cartography, a contour line (often just called a "contour") joins points of equal elevation (height) above a

given level, such as mean sea level. A **contour map** is a map illustrated with contour lines, for example a topographic map, which thus shows valleys and hills, and the steepness or gentleness of slopes. The **contour interval** of a contour map is the difference in elevation between successive contour lines.

Contour lines connect a series of points of equal elevation and are used to illustrate relief on a map. They show the height of ground above mean sea level (MSL) either in metres or feet, and can be drawn at any desired interval. For example, numerous contour lines that are close to one another indicate hilly or mountainous terrain; when further apart they indicate a gentler slope; and when far apart they indicate flat terrain.

More generally, a contour line for a function of two variables is a curve connecting points where the function has the same particular value.

The gradient of the function is always perpendicular to the contour lines. When the lines are close together the magnitude of the gradient is large: the variation is steep. A level set is a generalization of a contour line for functions of any number of variables.

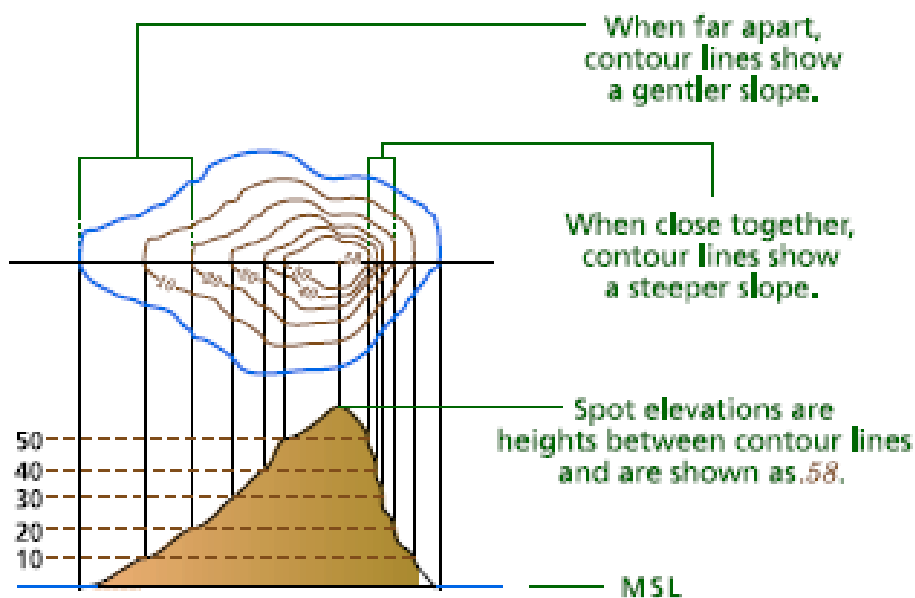

Contour lines are curved, straight or a mixture of both lines on a map describing the intersection of a real or hypothetical surface with one or more horizontal planes. The configuration of these contours allows map readers to infer the relative gradient of a parameter and estimate that parameter at specific places. Contour lines may be either traced on a visible three-dimensional model of the surface, as when a photogrammetrist viewing a stereo-model plots elevation contours, or interpolated from the estimated surface elevations, as when a computer program threads contours through a network of observation points of area centroids. In the latter case, the method of interpolation affects the reliability of individual iso-lines and their portrayal of slope, pits and peaks.

## Magnetic Declination :

**Magnetic declination**, or **magnetic variation**, is the angle on the horizontal plane between magnetic north (the direction the north end of a magnetized compass needle points, corresponding to the direction of the Earth's magnetic field lines) and true north (the direction along a meridian towards the geographic North Pole). This angle varies depending on position on the Earth's surface and changes over time.

Somewhat more formally, Bowditch defines variation as “the angle between the magnetic and geographic meridians at any place, expressed in degrees and minutes east or west to indicate the direction of magnetic north from true north. The angle between magnetic and grid meridians is called **grid magnetic angle**, **grid variation**, or **grivation**.”

By convention, declination is positive when magnetic north is east of true north, and negative when it is to the west.

**Isogonic lines** are lines on the Earth's surface along which the declination has the same constant value, and lines along which the declination is zero are called *agonic lines*. The lowercase Greek letter  $\delta$  (delta) is frequently used as the symbol for magnetic declination.

The term **magnetic deviation** is sometimes used loosely to mean the same as magnetic declination, but more correctly it refers to the error in a compass reading induced by nearby metallic objects, such as iron on board a ship or aircraft. Magnetic declination should not be confused with **magnetic inclination**, also known as **magnetic dip**, which is the angle that the Earth's magnetic field lines make with the downward side of the horizontal plane.

## Declination change over time and location

Magnetic declination varies both from place to place and with the passage of time. As a traveller cruises the east coast of the United States, for example, the declination varies from 16 degrees west in Maine, to 6 in Florida, to 0 degrees in Louisiana, to 4 degrees east (in Texas). The declination at London, UK was one degree west (2014), reducing to zero as of early 2020.

In most areas, the spatial variation reflects the irregularities of the flows deep in the Earth; in some areas, deposits of iron ore or magnetite in the Earth's crust may contribute strongly to the declination. Similarly, secular changes to these flows result in slow changes to the field strength and direction at the same point on the Earth.

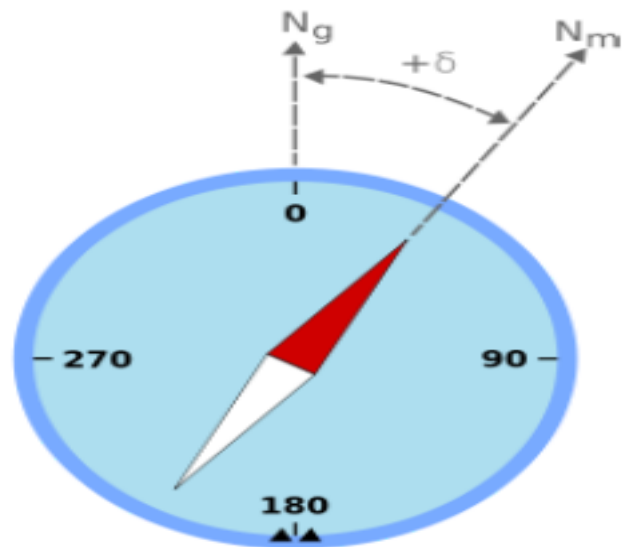

Example of magnetic declination showing a compass needle with a "positive" (or "easterly") variation from geographic north.  $N_g$  is geographic or true north,  $N_m$  is magnetic north, and  $\delta$  is magnetic declination

The magnetic declination in a given area may (most likely will) change slowly over time, possibly as little as 2–2.5 degrees every hundred years or so, depending upon how far from the magnetic poles it is. For a location closer to the pole like Ivujivik, the declination may change by 1 degree every three years. This may be insignificant to most travellers, but can be important if using magnetic bearings from old charts or metes (directions) in old deeds for locating places with any precision. As an example of how variation changes over time, see the two charts of the same area (western end of Long Island Sound), below, surveyed 124 years apart. The 1884 chart shows a variation of 8 degrees, 20 minutes West. The 2008 chart shows 13 degrees, 15 minutes West.

### **Determining declination**

#### **Direct measurement**

The magnetic declination at any particular place can be measured directly by reference to the celestial poles—the points in the heavens around which the stars appear to revolve, which mark the direction of true north and true south. The instrument used to perform this measurement is known as a *declinometer*.

The approximate position of the north celestial pole is indicated by Polaris (the North Star). In the northern hemisphere, declination can therefore be approximately determined as the difference between the magnetic bearing and a visual bearing on Polaris. Polaris currently traces a circle  $0.73^\circ$  in radius around the north celestial pole, so this technique is accurate to within a degree. At high latitudes a plumb-bob is helpful to sight Polaris against a reference object close to the horizon, from which its bearing can be taken.

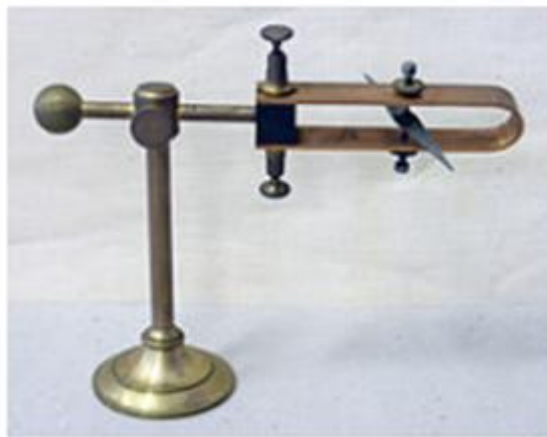

Antique declinometer

#### **Determination from maps and models**

A rough estimate of the local declination (within a few degrees) can be determined from a general isogonic chart of the world or a continent, such as those illustrated above. Isogonic lines are also shown on aeronautical and nautical charts.

Larger-scale local maps may indicate current local declination, often with the aid of a schematic diagram. Unless the area depicted is very small, declination may vary measurably over the extent of the map, so the data may be referred to a specific location on the map. The current rate and direction of change may also be shown, for example in arc minutes per year. The same diagram may show the angle of grid north (the direction of the map's north–south grid lines), which may differ from true north.

On the topographic maps of the U.S. Geological Survey (USGS), for example, a diagram shows the relationship between magnetic north in the area concerned (with an arrow marked "MN") and true north (a vertical line with a five-pointed star at its top), with a label near the angle between the MN arrow and the vertical line, stating the size of the declination and of that angle, in degrees, mils, or both.

A prediction of the current magnetic declination for a given location (based on a worldwide empirical model of the deep flows described above) can be obtained online from a web page operated by the National Geophysical Data Center, a division of the National Oceanic and Atmospheric Administration of the United States. This model is built with all the information available to the map-makers at the start of the five-year period it is prepared for. It reflects a highly predictable rate of change, and is usually more accurate than a map—which is likely months or years out of date—and almost never less accurate.

### 1.3.1 Software

The National Geospatial-Intelligence Agency (NGA) provides source code written in C that is based on the World Magnetic Model (WMM). The source code is free to download and includes a data file updated every five years to account for movement of the magnetic north pole.

### Navigation

On aircraft or vessels there are three types of bearing: true, magnetic, and compass bearing. Compass error is divided into two parts, namely magnetic variation and magnetic deviation, the latter originating from magnetic properties of the vessel or aircraft. Variation and deviation are signed quantities. As discussed above, positive (easterly) *variation* indicates that magnetic north is east of geographic north. Likewise, positive (easterly) *deviation* indicates that the compass needle is east of magnetic north.

Compass, magnetic and true bearings are related by:

$$T = M + V$$

$$M = C + D$$

The general equation relating compass and true bearings is:

$$T = C + D + V$$

Where:

- *C* is Compass bearing
- *M* is Magnetic bearing
- *T* is True bearing
- *V* is magnetic Variation



- $D$  is compass Deviation
- $V < 0, D < 0$  for westerly Variation and Deviation
- $V > 0, D > 0$  for easterly Variation and Deviation

For example, if the compass reads  $32^\circ$ , the local magnetic variation is  $-5.5^\circ$  (i.e. West) and the deviation is  $0.5^\circ$  (i.e. East), the true bearing will be:

$$T = 32^\circ + (-5.5^\circ) + 0.5^\circ = 27^\circ$$

To calculate true bearing from compass bearing (and known deviation and variation):

- ❖ Compass bearing + deviation = magnetic bearing
- ❖ Magnetic bearing + variation = true bearing

To calculate compass bearing from true bearing (and known deviation and variation):

- ❖ True bearing - variation = Magnetic bearing
- ❖ Magnetic bearing - deviation = Compass bearing

These rules are often combined with the mnemonic "West is best, East is least"; that is to say, add W declinations when going from True bearings to Magnetic bearings, and subtract E ones.

**Another simple way to remember which way to apply the correction for continental USA is:**

- ❖ For locations east of the agonic line (zero declination), roughly east of the Mississippi: the magnetic bearing is always bigger.
- ❖ For locations west of the agonic line (zero declination), roughly west of the Mississippi: the magnetic bearing is always smaller.

**Common abbreviations are:**

- TC = true course;
- V = variation (of the Earth's magnetic field);
- MC = magnetic course (what the course would be in the absence of local deviation);
- D = deviation caused by magnetic material (mostly iron and steel) on the vessel;
- CC = compass course.

**Deviation**

Magnetic deviation is the angle from a given magnetic bearing to the related bearing mark of the compass. Deviation is positive if a compass bearing mark (e.g., compass north) is right of the related magnetic bearing (e.g., magnetic north) and vice versa. For example, if the boat is aligned to magnetic north and the compass' north mark points  $3^\circ$  more east, deviation is  $+3^\circ$ . Deviation varies for every compass in the same location and depends on such factors as the magnetic field of the vessel, wristwatches, etc. The value also varies depending on the orientation of the boat. Magnets and/or iron masses can correct for deviation, so that a particular compass accurately displays magnetic bearings. More commonly, however, a correction card lists errors for the compass, which

can then be compensated for arithmetically. Deviation must be added to compass bearing to obtain magnetic bearing.

### **Public Land Survey System**

The **Public Land Survey System (PLSS)** is a method used in the United States to survey and identify land parcels, particularly for titles and deeds of rural, wild or undeveloped land. Its basic units of area are the township and section. It is sometimes referred to as the **rectangular survey system**, although non rectangular methods such as meandering can also be used. The survey was "the first mathematically designed system and nationally conducted cadastral survey in any modern country" and is "an object of study by public officials of foreign countries as a basis for land reform." The detailed survey methods to be applied for the PLSS are described in a series of Instructions and Manuals issued by the General Land Office, the latest edition being the "The Manual of Instructions for the Survey of the Public Lands Of The United States, 1973" available from the U.S. Government Printing Office. The Bureau of Land Management (BLM) announced in 2000 an updated manual is currently under preparation.

The **United States Public Land Survey System** (abbreviated **PLSS** or **USPLS**) is a locational reference system, but not strictly a planar coordinate system. It is different from the systems you have been reading about in a few important ways.

- It is used to locate areas, not points.
- It isn't rigorous enough for spatial analysis like the calculation of distance or direction.
- It is not a grid imposed on a map projection (a system invented in a room), but lines measured on the ground by surveyors.

The **PLSS** was established by Congress in 1785. Its purpose was to partition public lands into small, clearly-defined units so that settlement of the western United States could proceed in an orderly way. It covers about three-quarters of the country—the original thirteen colonies and Texas don't belong to it. There are other exceptions as well.

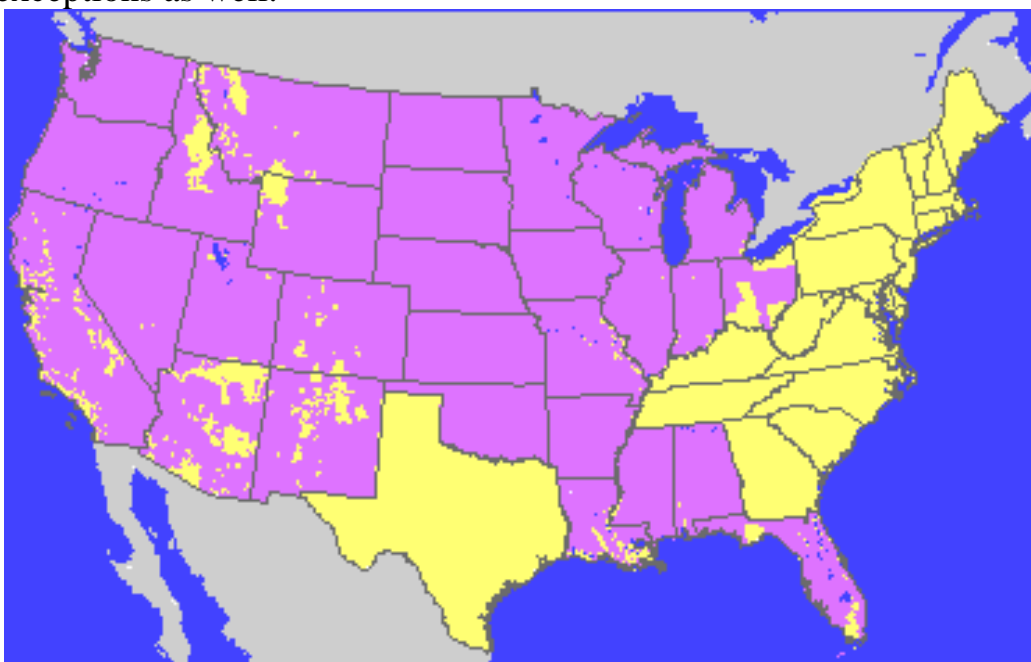

**Fig:** Areas covered by the Public Land Survey system are shown in purple.

### **How it works**

The basic unit of the **PLSS** is the township, an area six miles square. The system as a whole is a vast block of adjacent townships. Although it is not divided neatly into zones, the PLSS is made up of several regions, each with its own origin. Each origin is the intersection of a meridian (called a *principal meridian*) and a parallel (called a *baseline*). These more or less arbitrarily chosen locations define the starting point of the survey for a given region and the numbering scheme of the townships it includes. The principal meridians and baselines are shown in the following graphic. Each separate patch of color is a different region.

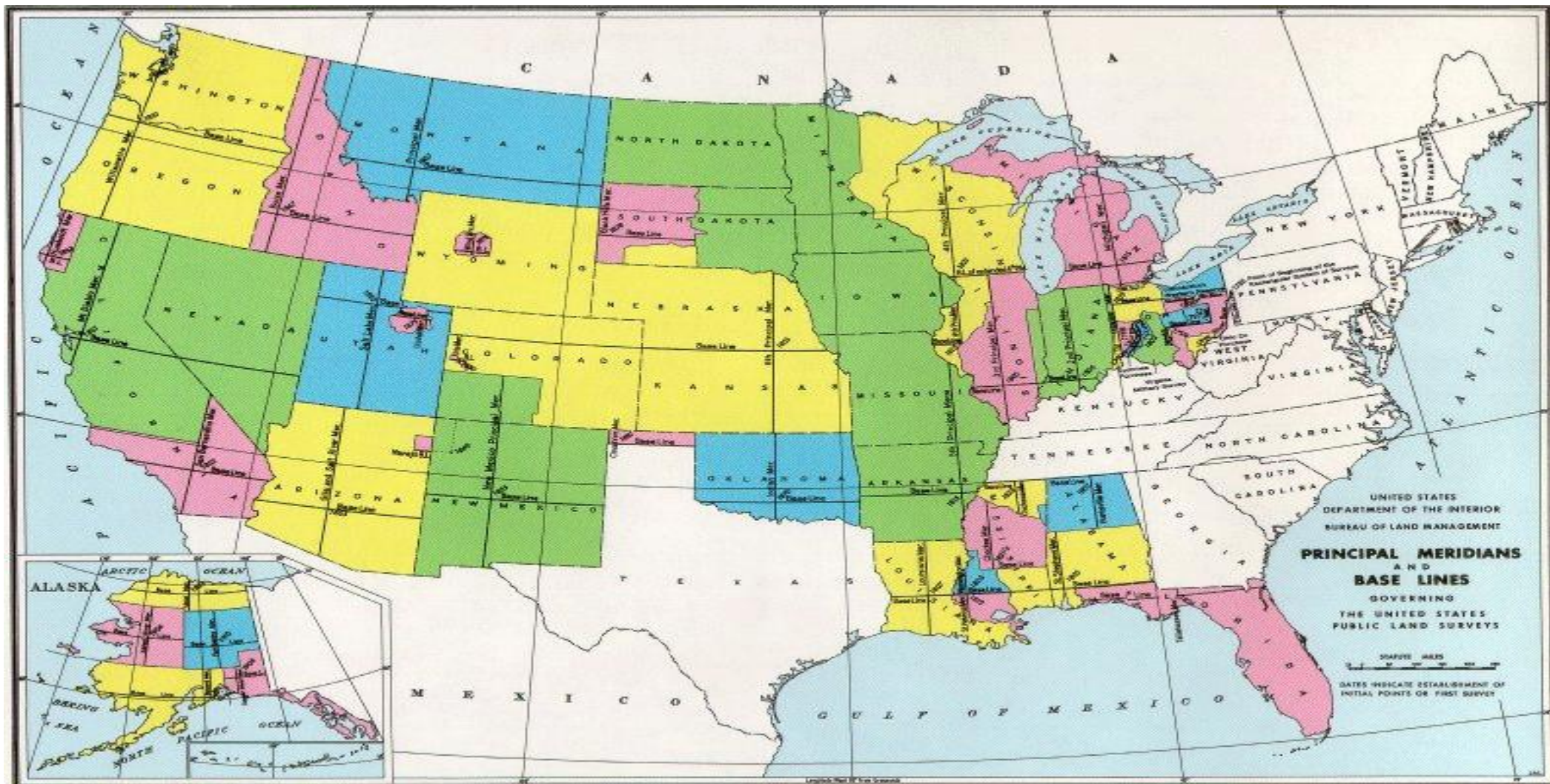

**Fig:** Principal meridians and baselines of the Public Land Survey system. This map was downloaded from the Web site of the Bureau of Land Management in California, Geographic Services department. See the module references for the URL.

The system divides into smaller and smaller units, always based on squares, as shown in the following graphics.

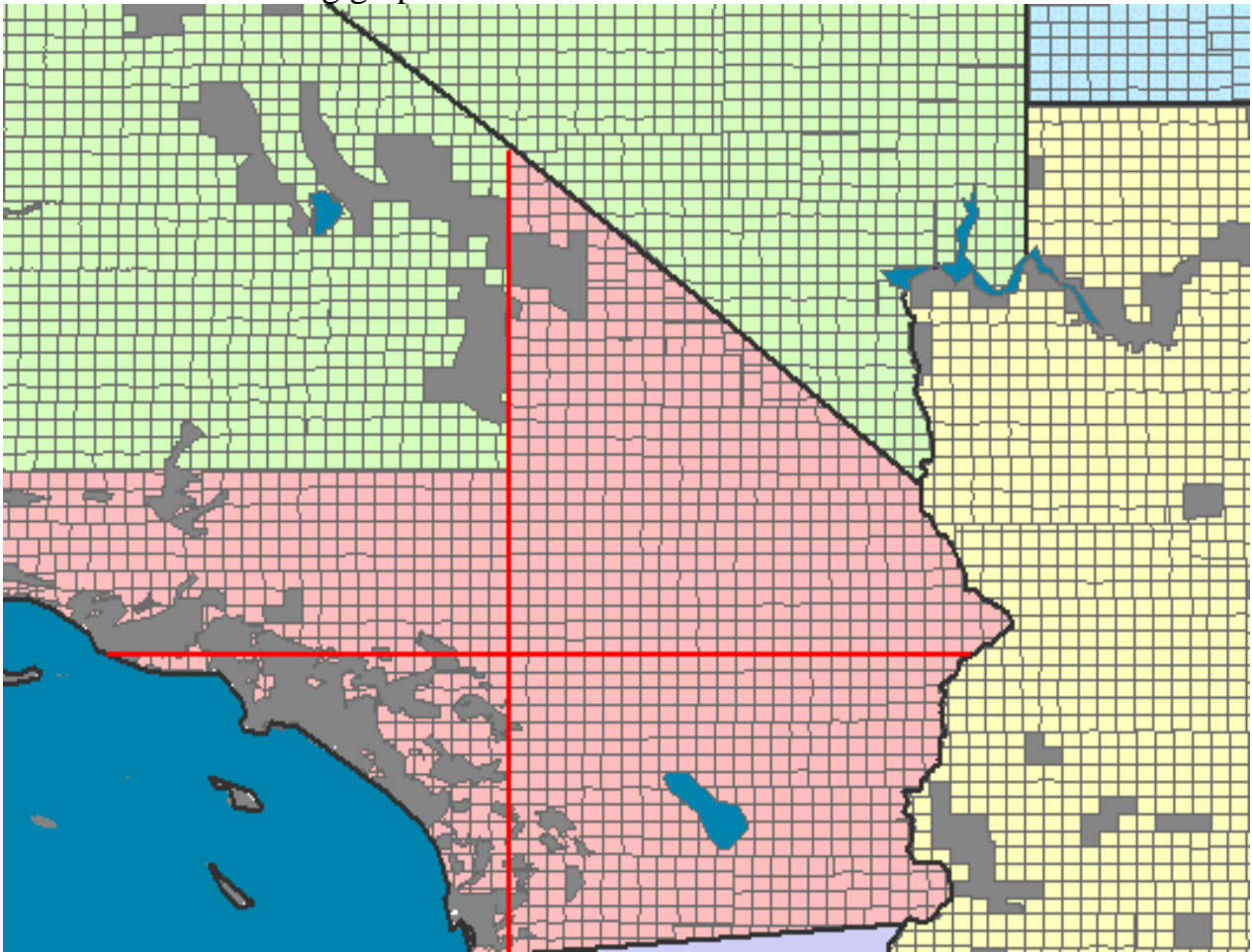

**Fig:** PLSS townships in southern California. Townships colored pink have been surveyed from the San Bernardino Principal Meridian and its baseline (red lines). The extent of a survey is often limited by state boundaries, as is the case here.

The gray areas are not part of the system. Some are unsurveyed because of difficult terrain, others are special land grants.

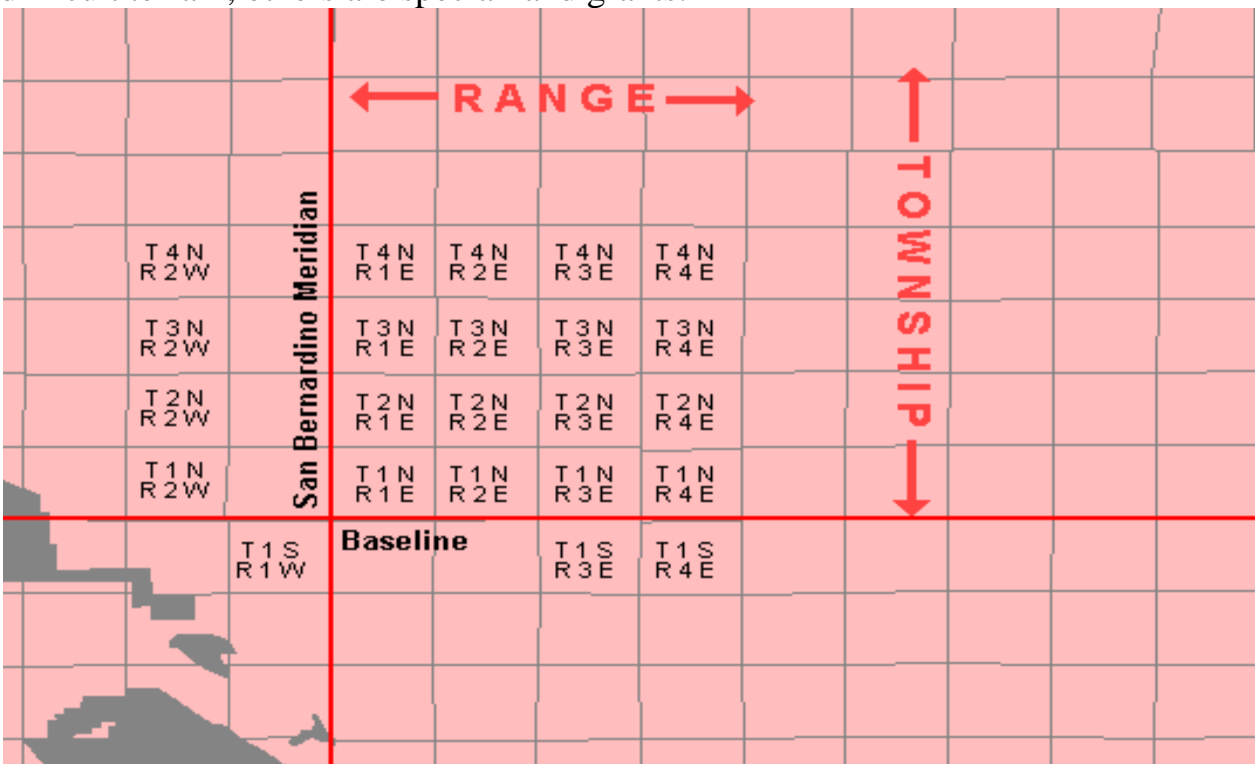

**Fig:** Each township, or six-square-mile block, is identified by a Township and Range label. The labels start at the intersection of the principal meridian and baseline. Township values (rows) increment north and south of the baseline. Range values (columns) increment east and west of the principal meridian. The numbering scheme continues to the boundary of an adjacent survey.

6	5	4	3	2	1
7	8	9	10	11	12
18	17	16	15	14	13
19	20	21	22	23	24
30	29	28	27	26	25
31	32	33	34	35	36

**Fig:** A township is divided into 36 sections, each a square mile (640 acres). Sections are numbered by row, beginning in the upper right corner. The numbers reverse direction with each row.

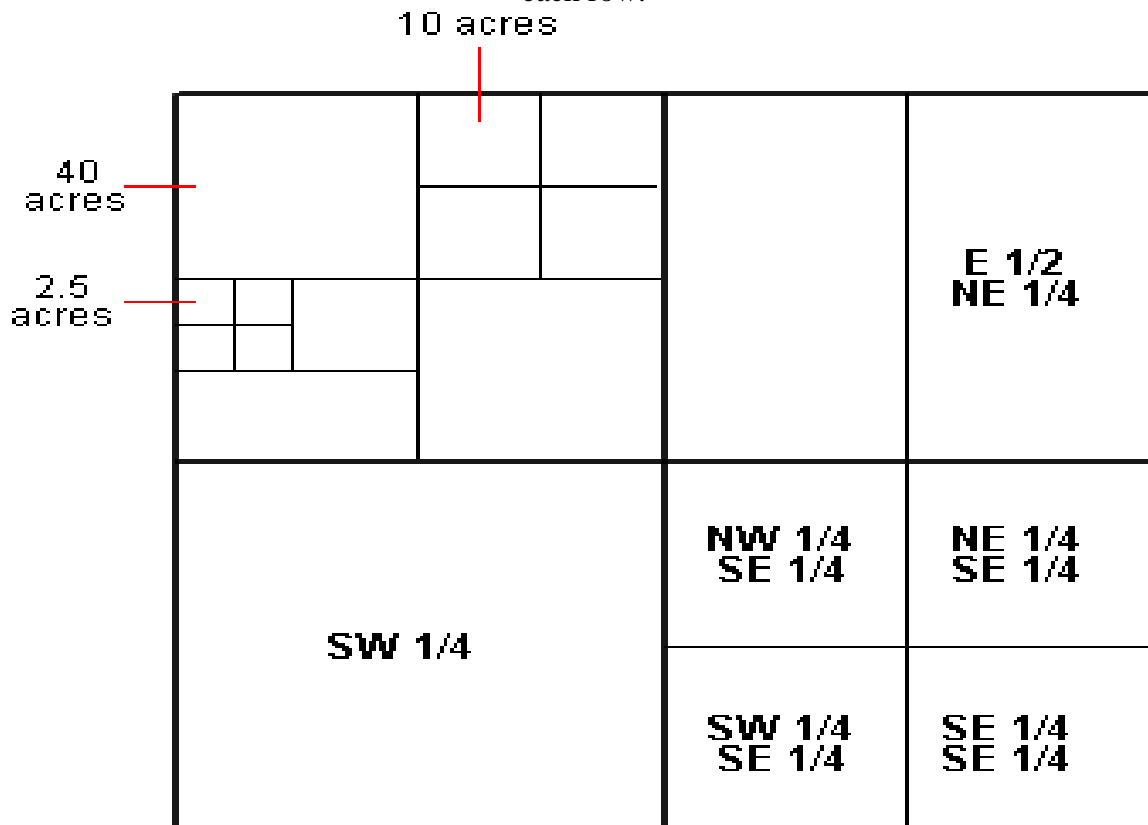

**Fig:** A section, in turn, is divided into 160-acre quarters, identified by quadrant (NW, NE, SW, SE). These quarters can be further divided into halves, quarters, and so on, with each piece identified by its geographic position. For example, the ten-acre square labeled in the graphic is the northwest quarter of the northeast quarter of the northwest quarter of the section.

To identify a location in PLSS, you start at the most detailed level and work your way out. In the graphic below, the location (indicated by blue squares) is: SW1/4, NE 1/4, Section 28, T.4N.-R.2E., San Bernardino P.M.

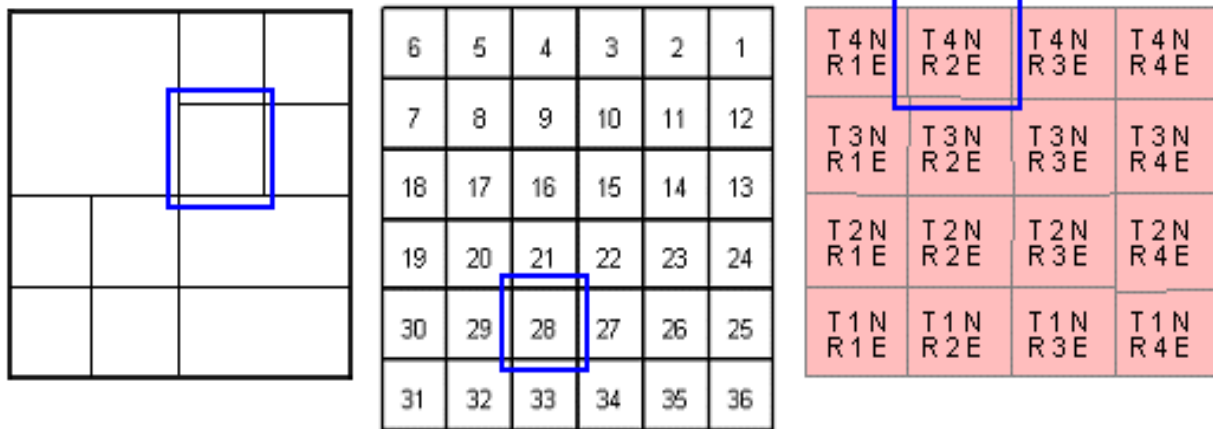

**Fig:** How a sample location is identified in the PLSS.

Since the PLSS framework is constructed from ground surveys, it has plenty of irregularities. In the first place, you can't lay out a grid of perfect squares over a large distance on the round earth. The PLSS makes corrections at every fourth township line and every fourth range line, so that townships are slightly offset from one another every 24 miles. In addition, many practical problems occur in the course of such a huge project and many surveying errors are made. Nonetheless, the PLSS is a very successful system and remains the basis for most land ownership documents in the United States.

### Field Notes

Field notes are written records of field work *made at the time the work is done*. Obviously, this means while you are in the field, not when you get back to camp or your office. Notes made after a field exercise, of just-remembered details or hypotheses you forgot to record on site, may be useful but they are not field notes. Notes other than field notes should be clearly labeled as such.

Field notes must be as complete, neat and accurate as possible, for the most careful and reliable field work will be of little or no value if the record of that work is unreliable or illegible. Making truly valuable, understandable field notes may be the most difficult thing that you will have to do while working in the field. It will require all of the alertness, care, accuracy, neatness, intelligence and geological knowledge you can muster.

Field notes should be records of the best possible pertinent field data available. Thus, the value of field reconnaissance should never be underestimated. To paraphrase the distinguished Tom Freeman (University of Missouri), before taking pencil and notebook in hand and digging into note-taking, invest some time in investigating your study area. All of us have had the experience of spending valuable time measuring and recording data at a particular location only to later find a much better outcrop (more complete, easier to measure, better fossils, etc...) just around the corner. Don't let this happen to you!

# BASICS OF AERIAL PHOTOGRAPHY, PHOTOGRAMMETRY, DEM AND ORTHO IMAGE GENERATION:

## Aerial Photography :

An aerial photograph, in broad terms, is any photograph taken from the air. Normally, air photos are taken vertically from an aircraft using a highly-accurate camera. There are several things you can look for to determine what makes one photograph different from another of the same area including type of film, scale, and overlap. Other important concepts used in aerial photography are stereoscopic coverage, fiducial marks, focal length, roll and frame numbers, and flight lines and index maps. The following material will help you understand the fundamentals of aerial photography by explaining these basic technical concepts.

### 1.3.2 Basic Concepts of Aerial Photography

**Film:** most air photo missions are flown using black and white film, however colour, infrared, and false-colour infrared film are sometimes used for special projects.

**Focal length:** the distance from the middle of the camera lens to the focal plane (i.e. the film). As focal length increases, image distortion decreases. The focal length is precisely measured when the camera is calibrated.

**Scale:** the ratio of the distance between two points on a photo to the actual distance between the same two points on the ground (i.e. 1 unit on the photo equals "x" units on the ground). If a 1 km stretch of highway covers 4 cm on an air photo, the scale is calculated as follows:

$$\frac{\text{PHOTO DISTANCE}}{\text{GROUND DISTANCE}} = \frac{4 \text{ cm}}{1 \text{ km}} = \frac{4 \text{ cm}}{100\,000 \text{ cm}} = \frac{1}{25\,000} \quad \text{SCALE: } 1/25\,000$$

Another method used to determine the scale of a photo is to find the ratio between the camera's focal length and the plane's altitude above the ground being photographed.

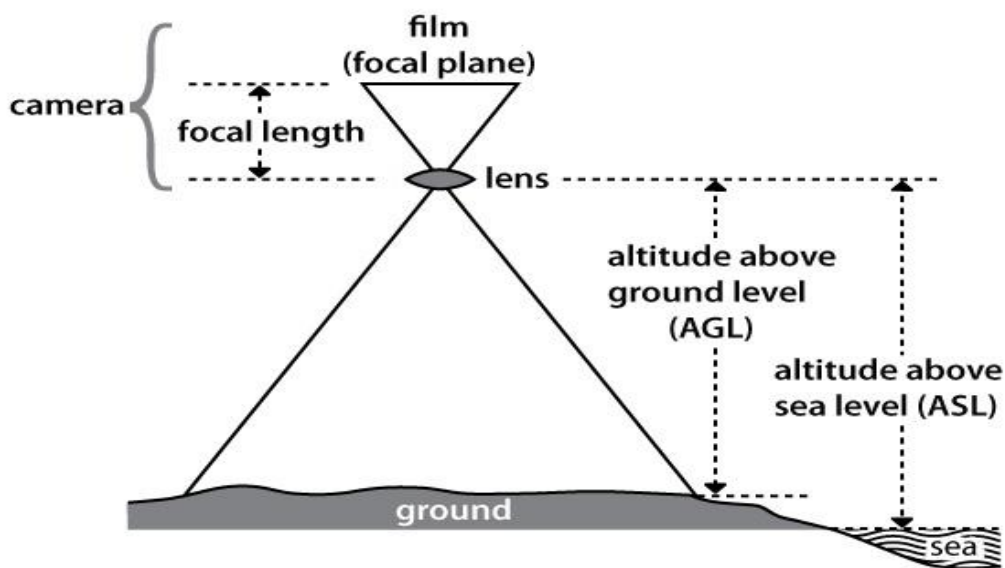

If a camera's focal length is 152 mm, and the plane's altitude Above Ground Level (AGL) is 7 600 m, using the same equation as above, the scale would be:



$$\frac{\text{FOCAL LENGTH}}{\text{ALTITUDE (AGL)}} = \frac{152 \text{ mm}}{7\,600 \text{ m}} = \frac{152 \text{ mm}}{7\,600\,000 \text{ mm}} = \frac{1}{50\,000} \quad \text{SCALE: } 1/50\,000$$

Scale may be expressed three ways:

- Unit Equivalent
- Representative Fraction
- Ratio

A photographic scale of 1 millimetre on the photograph represents 25 metres on the ground would be expressed as follows:

- Unit Equivalent - 1 mm = 25 m
- Representative Fraction - 1/25 000
- Ratio - 1:25 000

Two terms that are normally mentioned when discussing scale are:

**Large Scale** - Larger-scale photos (e.g. 1:25 000) cover small areas in greater detail. A large scale photo simply means that ground features are at a larger, more detailed size. The area of ground coverage that is seen on the photo is less than at smaller scales.

**Small Scale** - Smaller-scale photos (e.g. 1:50 000) cover large areas in less detail. A small scale photo simply means that ground features are at a smaller, less detailed size. The area of ground coverage that is seen on the photo is greater than at larger scales.

The National Air Photo Library has a variety of photographic scales available, such as 1:3 000 (large scale) of selected areas, and 1:50 000 (small scale).

**Fiducial marks:** small registration marks exposed on the edges of a photograph. The distances between fiducial marks are precisely measured when a camera is calibrated, and this information is used by cartographers when compiling a topographic map.

**Overlap:** is the amount by which one photograph includes the area covered by another photograph, and is expressed as a percentage. The photo survey is designed to acquire 60% forward overlap (between photos along the same flight line) and 30% lateral overlap (between photos on adjacent flight lines).

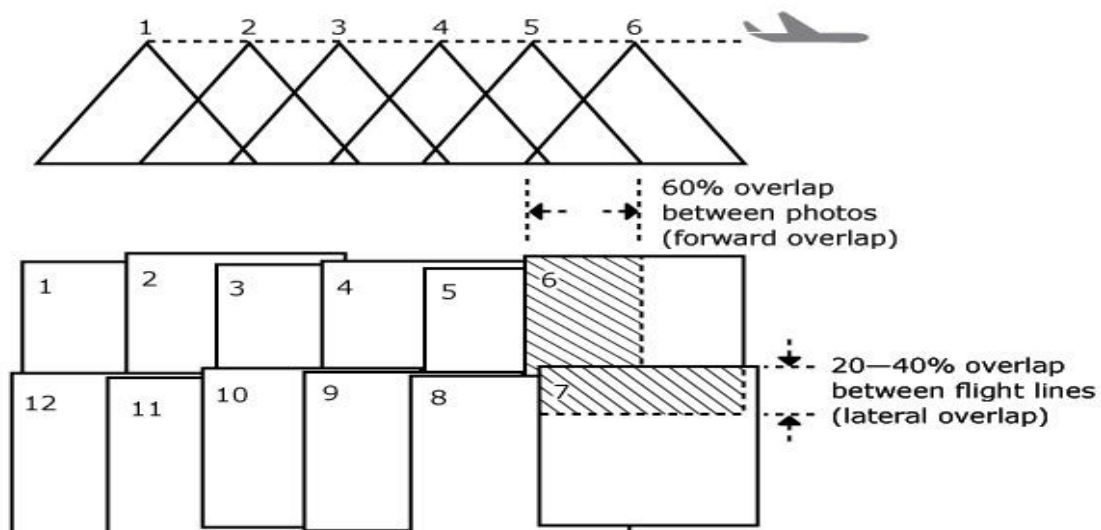

**Stereoscopic Coverage:** the three-dimensional view which results when two overlapping photos (called a stereo pair), are viewed using a stereoscope. Each photograph of the stereo pair provides a slightly different view of the same area, which the brain combines and interprets as a 3-D view.

**Roll and Photo Numbers:** each aerial photo is assigned a unique index number according to the photo's roll and frame. For example, photo A23822-35 is the 35th annotated photo on roll A23822. This identifying number allows you to find the photo in NAPL's archive, along with metadata information such as the date it was taken, the plane's altitude (above sea level), the focal length of the camera, and the weather conditions.

**Flight Lines and Index Maps:** at the end of a photo mission, the aerial survey contractor plots the location of the first, last, and every fifth photo centre, along with its roll and frame number, on a National Topographic System (NTS) map. Photo centres are represented by small circles, and straight lines are drawn connecting the circles to show photos on the same flight line.

This graphical representation is called an air photo index map, and it allows you to relate the photos to their geographical location. Small-scale photographs are indexed on 1:250 000 scale NTS map sheets, and larger-scale photographs are indexed on 1:50 000 scale NTS maps.

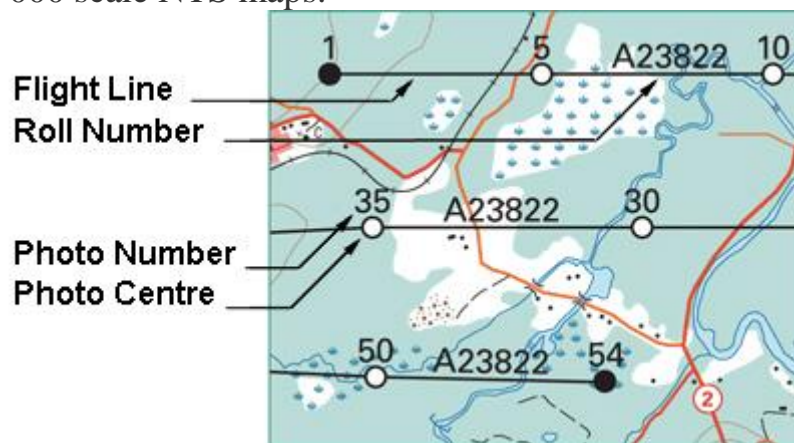

### **Types of Aerial Photographs :**

On the basis of the position of the camera axis, aerial photographs are classified into the following types: (A) **Vertical Aerial Photography** (B) **Oblique Aerial Photography**

(A) **Vertical aerial photography** is an aerial photography technique where the shots are taken from directly above the subject of the image. Allowable tolerance is usually  $+ 3^\circ$  from the perpendicular (plumb) line to the camera axis. This method of aerial photography is also referred as “overhead aerial photography.” In vertical aerial photograph, the lens axis is perpendicular to the surface of the earth. In vertical photograph, we may see flat and map-like image of the rooftops and canopies of the building and structure being photographed. There are three common ways that vertical aerial photography can be conducted: (i) Low Altitude – For this particular shot, the resulting images will show bigger and closer shots of the subject and its surroundings, (ii) Medium Altitude – Here, the resulting images of the subject and the surroundings are smaller than those produced in low altitude vertical aerial photography, (iii) High Altitude – The images of the subject and its surroundings produced from high altitude vertical

aerial photography are way smaller than those produced from low altitude and medium altitude vertical aerial photography. Nonetheless, they are able to cover a wider section of the land.

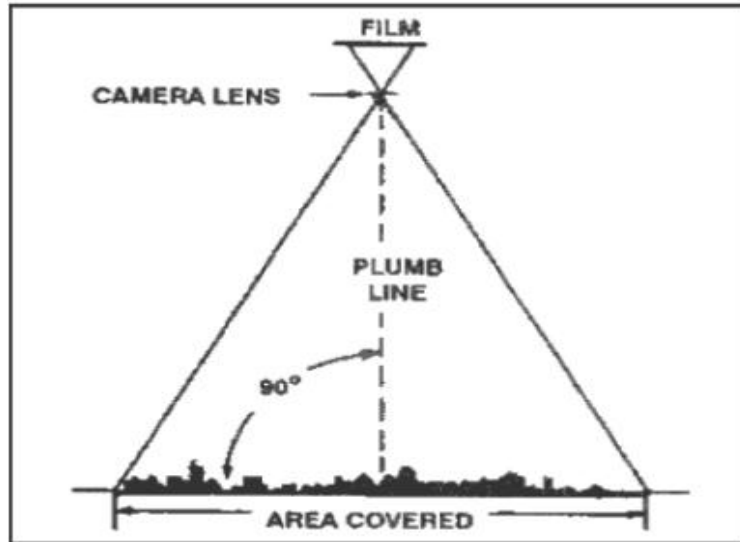

Vertical aerial photographs have no tilt in the camera axis.

### (B) Oblique Photography:

The word oblique means having a sloping direction or angular position. Therefore, Photographs taken at an angle are called oblique photographs. Oblique Photography is of two types.

(i) **Low Oblique Aerial Photography:** Low oblique aerial photograph is a photograph taken with the camera inclined about  $30^\circ$  from the vertical. In this type of photograph horizon is not visible. The ground area covered is a trapezoid, although the photo is square or rectangular. No scale is applicable to the entire photograph, and distance cannot be measured. Parallel lines on the ground are not parallel on this photograph; therefore, direction (azimuth) cannot be measured. Relief is detectable but distorted.

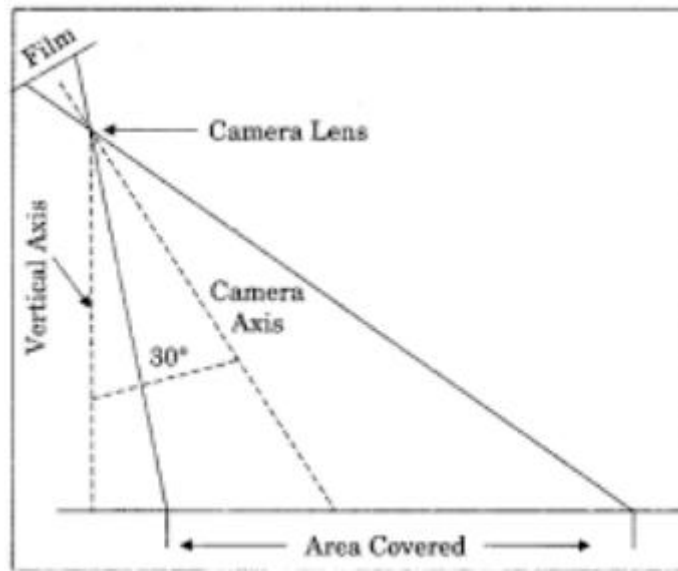
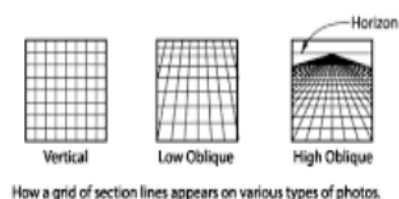
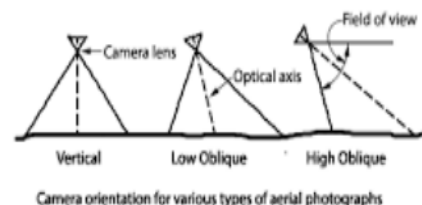
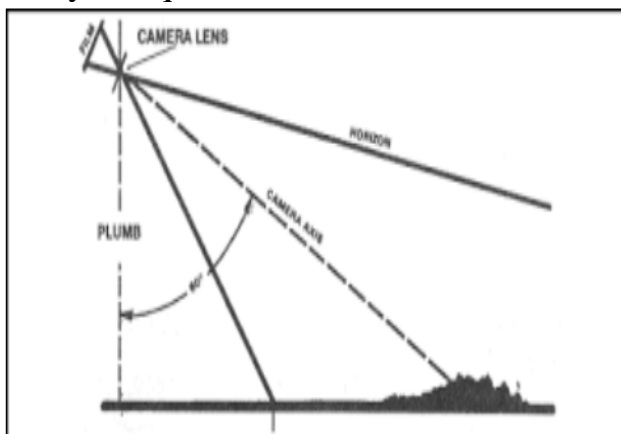

**Fig. Low Oblique Photograph**



Low oblique aerial photographs don't show the horizon.

(ii) **High Oblique Aerial Photography:** The high oblique is a photograph taken with the camera inclined about  $60^\circ$  from the vertical. In this type of aerial photograph horizon is visible. It covers a very large area. The ground area covered is a trapezoid, but the photograph is square or rectangular. Distances and directions are not measured on this photograph for the same reasons that they are not measured on the low oblique. Relief may be quite detectable but distorted as in any oblique view.





High oblique aerial photographs show the horizon.

### Comparison of photographs

Type of photo	Vertical	Low oblique	High oblique
Characteristics	Tilt <math>< 3^\circ</math>	Horizon does not appear	Horizon appears
Coverage	Least	Less	Greatest
Area	Rectangular	Trapezoidal	Trapezoidal
Scale	Uniform if flat	Decreases from foreground to background	Decreases from foreground to background
Difference with map	Least	Less	Greatest
Advantage	Easiest to map	-	Economical and illustrative

## Types of photographs

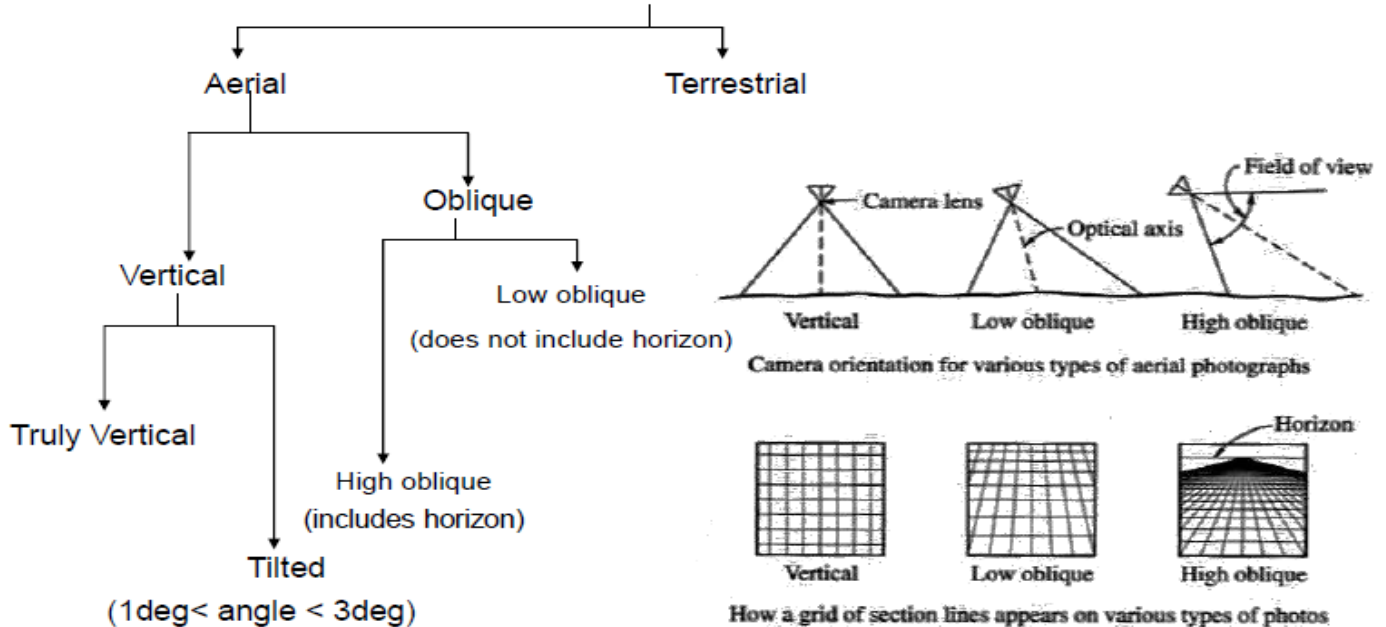

**FIGURE 1-6**  
Camera orientation for various types of aerial photographs.

### Photogrammetry:

❖ The photogrammetry has been derived from three Greek words:

**Photos:** means light

**Gramma:** means something drawn or written

**Metron:** means to measure

**Photo** = "Picture", **Grammetry** = "Measurement",  
therefore **Photogrammetry** = "Photo-Measurement"

- ❖ Objects are measured WITHOUT TOUCHING.
- ❖ It is a REMOTESENSING technique.
- ❖ It is a close range method of measuring objects.
- ❖ It is a 3-dimensional coordinate measuring technique that uses PHOTORAPHS as the fundamental medium for measurement.

### **Photogrammetric Surveying:**

- It is the branch of surveying in which maps are prepared from photographs taken from ground or air stations. Photographs are also being used for interpretation of geology, classification of soils, crops, etc.
- The art, science, and technology of obtaining reliable information about physical objects and the environment through process of recording, measuring, and interpreting photographic images and patterns of recorded radiant electromagnetic energy and phenomenon.
- Originally photogrammetry was considered as the science of analysing only photographs.

### **Advantages and Disadvantages:**

- Some advantages of photogrammetry over conventional surveying and mapping methods are:
- It provides a permanent photographic record of conditions that existed at the time the aerial photographs were taken. Since this record has metric characteristics, it is not only a pictorial record but also an accurate measurable record.
- If information has to be re-surveyed or re-evaluated, it is not necessary to perform expensive field work. The same photographs can be measured again and new information can be compiled in a very timely fashion. Missing information, such as inadequate offsets for cross sections, can be remedied easily.
- It can provide a large mapped area so alternate line studies can be made with the same data source can be performed more efficiently and economically than other conventional methods.
- It provides a broad view of the project area, identifying both topographic and cultural features.
- It can be used in locations that are difficult, unsafe, or impossible to access. Photogrammetry is an ideal surveying method for toxic areas where field work may compromise the safety of the surveying crew.
- An extremely important advantage of photogrammetry is that road surveys can be done without closing lanes, disturbing traffic or endangering the field crew. Once a road is photographed, measurement of road features, including elevation data, is done in the office, not in the field.
- Intervisibility between points and unnecessary surveys to extend control to a remote area of a project are not required. The coordinates of every point in the mapping area can be determined with no extra effort or cost.

- The aerial photographs can be used to convey or describe information to the public, State and Federal agencies, and other divisions within the Department of Transportation.

Some disadvantages are:

- Weather conditions (winds, clouds, haze etc.) affect the aerial photography process and the quality of the images.
- Seasonal conditions affect the aerial photographs, i.e., snow cover will obliterate the targets and give a false ground impression. Therefore, there is only a short time normally November through March that is ideal for general purpose aerial photography. A cleared construction site or a highway that is not obstructed by trees, is less subjected to this restriction. These types of projects can be flown and photographed during most of the year.
- Hidden grounds caused by man-made objects, such as an overpass and a roof, cannot be mapped with photogrammetry. Hidden ground problems can be caused by tree canopy, dense vegetation, or by rugged terrain with sharp slopes. The information hidden from the camera must be mapped with other surveying methods.
- The accuracy of the mapping contours and cross sections depends on flight height and the accuracy of the field survey.

### **Classification of Photogrammetry:**

Photogrammetry is divided into different categories according to the types of photographs or sensing system used or the manner of their use as given below:

#### **I. On the basis of orientation of camera axis:**

##### **a. Terrestrial or ground photogrammetry**

When the photographs are obtained from the ground station with camera axis horizontal or nearly horizontal.

Terrestrial Photogrammetry is that branch of photogrammetry where photographs are taken from a fixed, and usually known, position on or near the ground and with the camera axis horizontal or nearly so. The position and orientation of the camera are often measured directly at the time of exposure. The instrument used for exposing such photograph is called photo theodolite.

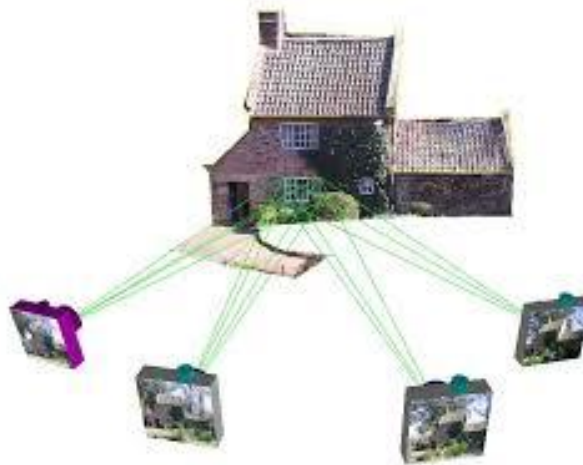

**Fig:** Terrestrial Photogrammetry

## b. Aerial photogrammetry

If the photographs are obtained from an airborne vehicle. The photographs are called vertical if the camera axis is truly vertical or if the tilt of the camera axis is less than  $3\sigma$ . If tilt is more than (often given intentionally), the photographs are called oblique photographs.

The camera is mounted in an aircraft and is usually pointed vertically towards the ground. Aerial photographs are taken from the air by special camera mounted in an aircraft flying over the area with the camera axis vertical or nearly so. Multiple overlapping photos of the ground are taken as the aircraft flies along a flight path. These photos are processed in a stereo-plotter (an instrument that lets an operator see two photos at once in a stereo view). These photos are also used in automated processing for Digital Elevation Model (DEM) creation.



**Fig:** Aerial Photogrammetry

## II. On the basis of sensor system used:

Following names are popularly used to indicate type of sensor system used:

- ❖ Radargrammetry: Radar sensor
- ❖ X-ray photogrammetry: X-ray sensor
- ❖ Hologrammetry: Holographs
- ❖ Cine photogrammetry: motion pictures
- ❖ Infrared or colour photogrammetry: infrared or colour photographs

## III. On the basis of principle of recreating geometry:

When single photographs are used with the stereoscopic effect, if any, it is called **Monoscopic Photogrammetry**.

If two overlapping photographs are used to generate three dimensional view to create relief model, it is called **Stereo Photogrammetry**. It is the most popular and widely used form of photogrammetry.

## IV. On the basis of procedure involved for reducing the data from photographs:

Three types of photogrammetry are possible under this classification:

- a. **Instrumental or Analogue photogrammetry:** It involves photogrammetric instruments to carry out tasks.
- b. **Semi-analytical or analytical:** Analytical photogrammetry solves problems by establishing mathematical relationship between coordinates on photographic image and real world objects. Semi-



analytical approach is hybrid approach using instrumental as well analytical principles.

- c. **Digital Photogrammetry or softcopy photogrammetry:** It uses digital image processing principle and analytical photogrammetry tools to carry out photogrammetric operation on digital imagery.

#### **V. On the basis of platforms on which the sensor is mounted:**

If the sensing system is space borne, it is called **Space Photogrammetry, Satellite Photogrammetry or Extra-terrestrial Photogrammetry**. Out of various types of the photogrammetry, the most commonly used forms are **Stereo Photogrammetry** utilizing a pair of vertical aerial photographs (stereo pair) or terrestrial photogrammetry using a terrestrial stereo pair.

#### **Application of Photographic Survey:**

Photogrammetry has been used in several areas. The following description give an overview of various applications areas of photogrammetry

- a. **Geology:** Structural geology, investigation of water resources, analysis of thermal patterns on earth's surface, geomorphological studies including investigations of shore features.
  - Stratigraphic studies
  - General geologic applications
  - Study of luminescence phenomenon
  - Recording and analysis of catastrophic events
  - Earthquakes, floods, and eruption.
- b. **Forestry:** Timber inventories, cover maps, acreage studies
- c. **Agriculture:** Soil type, soil conservation, crop planting, crop disease, crop-acreage.
- d. **Design and construction:** Data needed for site and route studies specifically for alternate schemes for photogrammetry. Used in design and construction of dams, bridges, transmission lines.
- e. **Planning of cities and highways:** New highway locations, detailed design of construction contracts, planning of civic improvements.
- f. **Cadastral:** Cadastral problems such as determination of land lines for assessment of taxes. Large scale cadastral maps are prepared for reapportionment of land.
- g. Environmental Studies:
- h. **Land-use studies.**
- i. **Urban area mapping.**
- j. **Exploration:** To identify and zero down to areas for various exploratory jobs such as oil or mineral exploration.
- k. **Military intelligence:** Reconnaissance for deployment of forces, planning manoeuvres, assessing effects of operation, initiating problems related to topography, terrain conditions or works.
- l. **Medicine and surgery:** Stereoscopic measurements on human body, X-ray photogrammetry in location of foreign material in body and location and examinations of fractures and grooves, biostereometrics.
- m. Mountains and hilly areas can be surveyed easily.
- n. **Miscellaneous**

## **Photogrammetry Process:**

### **Acquisition of Imagery using aerial and satellite platform**

For most photogrammetric mapping purposes, the goal is to image as much of the actual ground surface as possible. For this reason, it is customary to fly projects when deciduous trees are without leaves, when the ground is clear of snow and ice, when lakes and streams are within their normal banks, and when the sun is high overhead, minimizing shadows. In many parts of the world, this limits the optimal season for mapping to early spring, when days are getting long but trees are relatively bare. Add the need for cloud-free skies to all these other requirements, and you can see why the flight operations of most photogrammetric mapping companies are not a big profit center. For any given location, there are a relatively small number of days per year when all the conditions are right for image acquisition.

By the way, these requirements are no different for space-based image acquisition. You already know that the orbits of passive imaging satellites are designed to follow local noon. That takes care of the time of day requirement. Add in all the other requirements, plus the constraints of orbital parameters and revisit times, and you can easily see why large-scale state and county mapping projects are still accomplished with aircraft. I'm sure we'll eventually see seamless coverage of states and nations with large-scale (1 meter/pixel GSD or better) satellite imagery, but it won't all be taken in the same season or even in the same year. Not until there are many, many more high-resolution imaging satellites circling the globe.

Several key computations related to flight planning are identified in these documents. These are:

- flight altitude above the ground required to achieve specified photo scale
- number of flightlines required to cover project area
- distance between (and total number of) flightlines required to achieve specified sidelap
- distance between (and total number of) successive exposures to achieve specified overlap
- total number of exposures required to complete project

### **Control Survey:**

The second element of the photogrammetric process is control, which is used to establish the position and orientation of the camera at the instant of exposure. The necessity, accuracy and the rigor of photogrammetric control depends on the particular product sought. Photo mosaics used for annotation, cultural studies, public meetings, and other varied purposes may not require any control. Rectified aerial photographs, used mainly for photo plan sheets, may require partial control in the form of measured distances. Field measured distances are scaled down to match corresponding distances on the photograph. However, most common photogrammetric products, such as mapping and orthophotography, require full control information. The minimum full control to establish a stereo model is two points with known horizontal positions (for scaling) and three points with known elevations (for orientation). Using this bare minimum is unacceptable; therefore, additional control is required for a processing a stereo model. Photographs can be controlled using three different methods:

1. Ground control points that were surveyed on the ground using ordinary surveying techniques.
2. Bridging control through aerial triangulation. Bridging is accomplished by measuring on the photographs common points that appear in three consecutive photographs or in two adjacent strips and computing their 3 D coordinate values.
3. Aerial photography control through kinematic GPS technique in which the position and the attitude of the camera are computed without ground control.

In most photogrammetric projects, a combination of all or some of these methods are utilized.

#### **1.3.2.1.1.1 Ground Control:**

Ground control can be classified as targeted and photo-identifiable (picked) control points, and can also be classified as horizontal control, vertical only control, or as 3-D control. Horizontal and vertical controls require different configurations to make them serve their intended purposes. The use of only ground control is now limited to small projects, such as bridge sites, borrow areas and where only one or two models are needed. Photo identifiable control points are rarely needed. The surveyor needs to know what type of control is called for when he or she attempts to pick or photo-identify the point. Accessibility for surveying should also be considered when selecting the locations for control points.

#### **1.3.2.1.1.2 Field Survey of Photogrammetric Control**

Field surveys for photogrammetric control should be treated as ordinary surveys. The methods and procedures that are described in this manual must be applied to photogrammetric control field work. The key issue here is to select suitable survey procedures that address the project requirements.

Photogrammetric control points are usually spaced widely around the project area. For large projects, this spacing could be extensive enough to require a significant surveying effort. Therefore, GPS is the better suited surveying method for most large photogrammetric projects.

Ground control that is to be used in successive photogrammetric projects or field surveys should be monumented accordingly

#### **1.3.2.1.1.3 GPS as Control for Photogrammetry**

In recent years, GPS has been demonstrated to be able to replace, partially or entirely, the need for ground control. The basic concept of GPS controlled photogrammetry is to use GPS equipment to determine the position and orientation of the camera at the instant of exposure. Remember that the only reason for using ground control in photogrammetry is to recover the position and orient a photograph in space at the time that the photograph was taken. If the values of these parameters can be resolved at the time of photography with GPS and/or additional instruments, there is no need for ground control to compute them. Even if GPS controlled photography is not yet at a level of maturity to be able to completely replace the need for ground control, it does reduce the number of field surveyed control points in a given project.

## Geometric Distortion in Imagery

Any remote sensing image, regardless of whether it is acquired by a multispectral scanner on board a satellite, a photographic system in an aircraft, or any other platform/sensor combination, will have various geometric distortions. This problem is inherent in remote sensing, as we attempt to accurately represent the three-dimensional surface of the Earth as a two-dimensional image. All remote sensing images are subject to some form of geometric distortions, depending on the manner in which the data are acquired. These errors may be due to a variety of factors, including one or more of the following, to name only a few:

- ❖ The perspective of the sensor optics,
- ❖ The motion of the scanning system,
- ❖ The motion and (in)stability of the platform,
- ❖ The platform altitude, attitude, and velocity,
- ❖ The terrain relief, and
- ❖ The curvature and rotation of the earth.

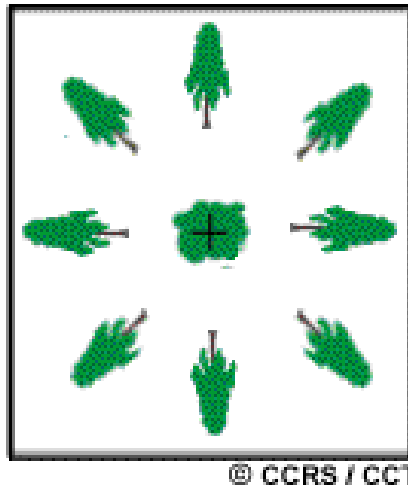

Framing systems, such as cameras used for aerial photography, provide an instantaneous "snapshot" view of the Earth from directly overhead. The primary geometric distortion in vertical aerial photographs is due to **relief displacement**. Objects directly below the centre of the camera lens (i.e. at the **nadir**) will have only their tops visible, while all other objects will appear to lean away from the centre of the photo such that their tops and sides are visible. If the objects are tall or are far away from the centre of the photo, the distortion and positional error will be larger.

The geometry of along-track scanner imagery is similar to that of an aerial photograph for each scan line as each detector essentially takes a "snapshot" of each ground resolution cell. Geometric variations between lines are caused by random variations in platform altitude and attitude along the direction of flight.

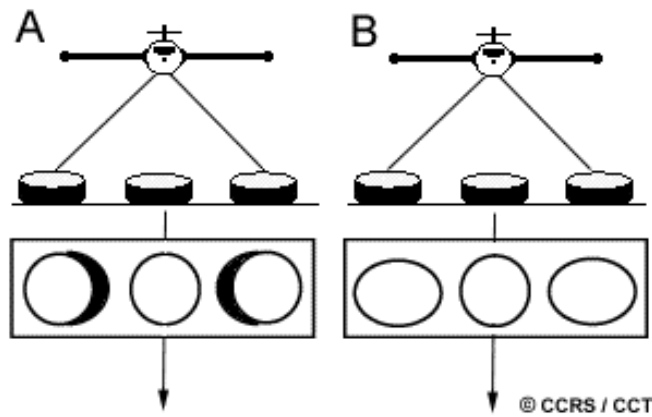

Images from across-track scanning systems exhibit two main types of **geometric distortion**. They too exhibit relief displacement (A), similar to aerial photographs, but in only one direction parallel to the direction of scan. There is no displacement directly below the sensor, at nadir. As the sensor scans across the swath, the top and side of objects are imaged and appear to lean away from the nadir point in each scan line. Again, the displacement increases, moving towards the edges of the swath. Another distortion (B) occurs due to the rotation of the scanning optics. As the sensor scans across each line, the distance from the sensor to the ground increases further away from the centre of the swath. Although the scanning mirror rotates at a constant speed, the IFOV of the sensor moves faster (relative to the ground) and scans a larger area as it moves closer to the edges. This effect results in the compression of image features at points away from the nadir and is called **tangential scale distortion**.

All images are susceptible to geometric distortions caused by variations in platform stability including changes in their speed, altitude, and attitude (angular orientation with respect to the ground) during data acquisition. These effects are most pronounced when using aircraft platforms and are alleviated to a large degree with the use of satellite platforms, as their orbits are relatively stable, particularly in relation to their distance from the Earth. However, the eastward rotation of the Earth, during a satellite orbit causes the sweep of scanning systems to cover an area slightly to the west of each previous scan. The resultant imagery is thus skewed across the image. This is known as **skew distortion** and is common in imagery obtained from satellite multispectral scanners.

The sources of geometric distortion and positional error vary with each specific situation, but are inherent in remote sensing imagery. In most instances, we may be able to remove, or at least reduce these errors but they must be taken into account in each instance before attempting to make measurements or extract further information.

### **Application of Imagery and its support data**

Photogrammetry is used in fields such as topographic mapping, architecture, engineering, manufacturing, quality control, police investigation, cultural heritage, and geology. Archaeologists use it to quickly produce plans of large or complex sites, and meteorologists use it to determine the wind speed of tornados when objective weather data cannot be obtained.

Photogrammetry is also commonly employed in collision engineering, especially with automobiles. When litigation for accidents occurs and engineers need to determine the exact deformation present in the vehicle, it is common for

several years to have passed and the only evidence that remains is accident scene photographs taken by the police. Photogrammetry is used to determine how much the car in question was deformed, which relates to the amount of energy required to produce that deformation. The energy can then be used to determine important information about the crash (such as the velocity at time of impact).

### **Orientation and Triangulation**

Aerial triangulation, or aerotriangulation, is the process of determining X, Y, and Z ground coordinates of individual points based on measurements from photographs. Aerial triangulation is used extensively for many purposes. One of the principal applications is densifying ground control through strips or a block of photos to be used in subsequent photogrammetric operations. When used for this purpose it is often called bridging, because it allows the computation of necessary control points between those measured in the field. In a large project, with dozens of photographs, the effort and cost of providing the needed control using field surveys is prohibitive. Aerial triangulation is used to provide the necessary control for each stereo model with only a limited number of field surveyed control point. Other advantages of aerial triangulation are:

- ❖ The control densification is done in the office, thus minimizing delays and hardships due to adverse weather conditions.
- ❖ Field surveys in difficult or unsafe areas are minimized.
- ❖ Access to much of the (private or public) property within a project area is not required.
- ❖ The aerial triangulation process provides accuracy and consistency checks for the field surveyed control points.

### **Stereoscopic Measurement**

The term parallax refers to the **apparent change in relative position of stationary objects caused by a change in viewing position**. As applied to aerial photos, the parallax of a point is the apparent difference in position of the point on two consecutive photographs.

This phenomenon is observable when one looks at objects through a side window of a moving vehicle. With the moving window as a frame of reference, objects such as mountains at a relatively great distance from the window appear to move very little within the frame of reference. In contrast, objects close to the window, such as roadside trees, appear to move through a much greater distance. In the same way terrain features close to an aircraft (i.e. at higher elevation) will appear to move relative to the lower elevation features when the point of view is changes between successive exposures. These relative displacements form the basis of three-dimensional viewing of overlapping photography. In addition, they can be measured and used to compute the elevations of terrain points.

The parallax can be resolved in two components one in the direction of flight and is known as **X-parallax or absolute parallax** and the other perpendicular to the flight direction known as **Y-parallax**.

Y- parallax is zero if the photos are tilt free and have taken from the same altitude.

The absolute stereoscopic parallax is the algebraic difference, in the direction of the flight, of the distance of the two images of the object from their respective principal points.

The parallax difference can be used to determine the height of the objects and the dip and slope from the stereo pairs.

Parallax is an apparent shift in the position of an object due to shift in the position of the observer camera (in aerial surveying). We experience this phenomenon when a moving body ( a shift in position when compared to a static object considering camera as eye). This is depended on the distance between the observer and the object. Nearer object move faster than that of the far distanced object, similar is the case of an aerial camera exposed to overlapping photographs which is caused by the movement of the aircraft is termed as **stereoscopic parallax**.

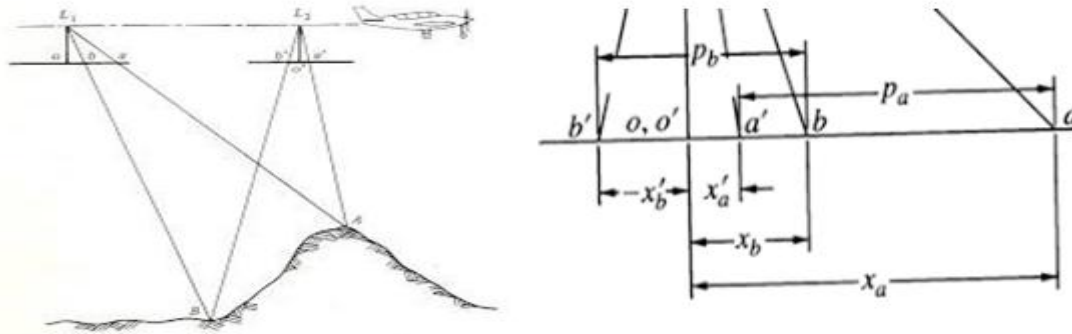

Fig. The images explain the parallax of the area.

The above figure determine the images of object at points A and B; is considered as the part of the overlapping area within the two successive imagery vertical aerial images taken from the camera at the position in the space. Camera focus on point parallel to the flight line. In the side image they appear as a' and b'. Point A movement is greater because it occurs at higher position than that of the point B. The stereoscopic parallax at A and B are parallax a(Pa) and parallax b(Pb).

$$P_a = X_a - X_b'$$

This is consider as the x direction parallax, similarly, to the x, y is also calculated to the relative position of the object in the imagery. As explained in the second figure  $X_a$  and  $X_a'$  are the measuring photo coordinates of object A an the left and right respectively. These coordinates are not from the fiduciary system but are based on the flight direction of point X and X' for measuring the parallax. It can be along the flight line for every imagery which is captured during the data acquisition of a stereoscopic pair.

### DTM(Digital Terrain Models and even)/DEM(Digital Elevation Models ) Generation

A **digital elevation model (DEM)** is a 3D computer graphics representation of elevation data to represent terrain, commonly of a planet, moon, or asteroid. A "global DEM" refers to a discrete global grid. DEMs are used often in geographic information systems, and are the most common basis for digitally produced relief maps. While a digital surface model (DSM) may be useful for landscape modeling, city modeling and visualization applications, a digital terrain model (DTM) is often required for flood or drainage modeling, land-use studies, geological applications, and other applications, and in planetary science.

There is no universal usage of the terms *digital elevation model (DEM)*, *digital terrain model (DTM)* and *digital surface model (DSM)* in scientific

literature. In most cases the term *digital surface model* represents the earth's surface and includes all objects on it. In contrast to a DSM, the *digital terrain model* (DTM) represents the bare ground surface without any objects like plants and buildings (see the figure on the right).

DEM is often used as a generic term for DSMs and DTMs, only representing height information without any further definition about the surface. Other definitions equalise the terms DEM and DTM, equalise the terms DEM and DSM,[8] define the DEM as a subset of the DTM, which also represents other morphological elements, or define a DEM as a rectangular grid and a DTM as a three-dimensional model (TIM). Most of the data providers (USGS, ERSDAC, CGIAR, Spot Image) use the term DEM as a generic term for DSMs and DTMs. Some data sets such as SRTM or the ASTER GDEM are originally DSMs, although in forested areas, SRTM reaches into the tree canopy giving readings somewhere between a DSM and a DTM). It is possible to estimate a DTM from higher solution DSM datasets with complex algorithms (Li *et al.*, 2005). In the following, the term DEM is used as a generic term for DSMs and DTMs.

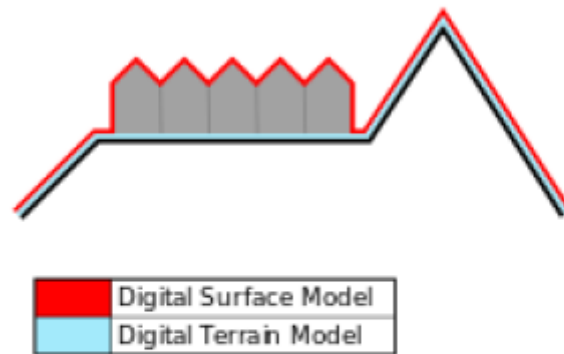

Surfaces represented by a Digital Surface Model include buildings and other objects. Digital Terrain Models represent the bare ground.

DEM generation contains four important steps, (i) geometric modelling using photogrammetric collinearity conditions (ii) automatic conjugate point identification using hierarchical matching technique (iii) three dimensional ground co-ordinate determination of identified conjugate points and (iv) height interpolation & DEM editing. Using these concepts a software package is developed and well tested using IRS-1 C data sets.

The DEM/Orthoimage generation software, which is developed at Space Applications Centre for IRS-1C stereo data is purely in digital mode, using the softcopy photogrammetric workstation based on R- 10000 Silicon Graphics workstation. This system has a capability of generating stereo pairs (more than one, if map sheet falls between two successive strips of same 70 km PAN scene) for a given 1:25000 scale Survey of India (SOI) map sheet. Generation of stereo pair products, are done through a scheduler and DEM and orthoimage generation are done using a separate package. At the end mosaicing of orthoimages can be performed if the map sheet lies between two successive strips of same 70 km



PAN scene. This package uses a semi-automatic mode of operation for deriving DEM. Various functionalities involved in DEM generation are as follows:

- (a) Input Work order Entry
- (b) Scene Selection
- (c) Data Downloading and Pre-processing
- (d) GCP collection
- (e) Model Setup
- (f) Conjugate Point Identification
- (g) Determination of 3D Ground co-ordinates
- (h) DEM interpolation
- (i) DEM editing

### Ortho Image Generation

An **orthophoto**, **orthophotograph** or **orthoimage** is an aerial photograph or satellite imagery geometrically corrected ("orthorectified") such that the scale is uniform: the photo or image follows a given map projection. Unlike an uncorrected aerial photograph, an orthophoto can be used to measure true distances, because it is an accurate representation of the Earth's surface, having been adjusted for topographic relief, lens distortion, and camera tilt.

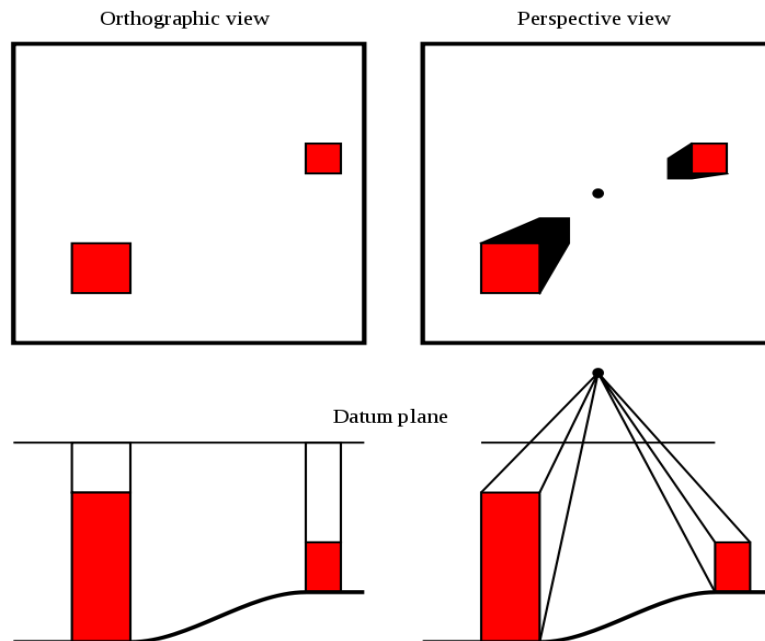

Orthographic views project at a right angle to the data plane. Perspective views project from the surface onto the datum plane from a fixed location.

Once the DEM, updated orientation parameters and image are available, the important steps in orthoimage generation process are as follows:

**(a) Grid Generation:** The geometric correction grid in a given map projection is prepared at regular intervals using ground to image mapping generated with the collinearity condition equations [Stereo Products Design Team, 1993; RebantaMitra et al, 1994b]. This transformation relates the input coordinates in one of the stereo images corresponding to the geodetic output co-ordinate on the basis of satellite orientation parameters.

**(b) Resampling:** Once the correction grid is generated, using a cubic convolution image resampling on the input image, output corrected grey

level image is generated. Freedman resampling algorithm is implemented in this case. The coordinates within the grid are approximated using a bilinear transformation.

**(c) Tickmark and Product Generation:** Tickmarks are generated for every 2' interval of tile 7.5' x 7.5' area (corresponds to 1:25000 scale map) and are appended along with other relevant product information.

# MODERN SURVEYING METHODS

## **Introduction:**

The measurement of angles and distances is the focus of all land surveying jobs. In your earlier courses, you have been introduced to the use of a number of field equipment for a variety of surveying works such as control establishment, route surveying, construction and mapping surveys. Over the years, due to the advancement in electronics and computer technologies, ranges of electronic equipment have been developed in the field of surveying and levelling. With the introduction of these equipment, not only the efficiency of the work has increased but the jobs can now be performed with more precision and accuracy within much lesser time than before. Further, with the inclusion of data recording facilities in these equipment, a large amount of data can be stored in proper format which can then be analysed with the computer. Some of the modern equipment are Electronic Distance Measuring (EDM) equipment, Optical and Electronic Theodolites, Auto and Digital Levels, Total Stations and Global Positioning System (GPS). These equipment can provide accurate data in no time that can be recorded in suitable media which can then be connected to a computer to generate quality map products.

In this unit, an introduction to some important modern surveying equipment and their use has been explained. The first section deals with the angle measuring equipment such as micro-optic and electronic theodolites. In the next section, the EDM has been discussed. This is followed by a discussion on electronic and auto levels. The penultimate section provides details on the Total Station that can be used for angle, distance and height measurements in one go. In the last section, an introduction to the latest technology, namely GPS, has been provided.

## **Principles, features and use of (i) Micro-optic theodolite, digital theodolite**

### **Micro-Optic and Electronic Theodolites:**

As you know that the survey field measurements include distances (horizontal and sloping) and angles (horizontal and vertical) measurement. The latter can be measured with a transit, or theodolite. You have already studied the use of vernier theodolites that are designed to read angles to the closest minute, 20 seconds or 10 seconds. Over the years, the vernier theodolites have been in practice for conducting surveys of ordinary precision. For very precise surveys, these have been superseded by modern theodolites. The modern theodolites can be categorised as micro-optic and electronic theodolites. Unlike vernier theodolite, the observations are taken through an auxiliary eyepiece (i.e. through optics) in the micro-optic theodolites and hence the name. In electronic theodolites, the observations are taken from the visual displays. These can read, record, display and store horizontal and vertical angles in the electronic recorder attached to them.

### **Micro-optic Theodolites:**

The design of these instruments is such that these become compact and light-weight. These are generally characterised by a three-foot screw levelling head and an optical plummet. There is a circular level for approximate levelling and a plate level for precise levelling. Optical plummet is provided for accurate centering particularly in windy climatic conditions. The plummet consists of a small eyepiece generally built into the tribach. The graduations are marked on

horizontal and vertical circles made up of glass. The observations are read through an optical reading system that consists of a series of prisms. The vertical circle is normally graduated such that 0° corresponds to the telescope pointing upwards towards the zenith. The graduations increase clockwise with 90° and 270° marked on the horizontal line and 180° on the vertical line pointing downwards towards the nadir. The glass circles are read with the aid of an eyepiece adjacent to the telescope. The angles can be read to a least count of 1". Many manufacturers have developed a variety of micro-optic theodolites each having a particular optical system such as circle microscope system, optical scale system, single reading optical micrometer and double reading optical micrometer etc.

A list showing the performance of some of the direction measuring equipment is given in Table

**Table : Some Micro-optic Theodolites for Angle Measurement**

Sl. No.	Name of Instrument	Make	Least Count	
			Direct (Seconds)	Estimation (Seconds)
1.	T2 (Universal)	Leica, Switzerland	1.0	0.5
2.	T3 (Precision)	Leica, Switzerland	0.2	0.1
3.	T4 (Astronomy)	Leica, Switzerland	0.1	0.05
4.	Theo 010	Zeiss, Germany	1.0	0.1

Wild T3 theodolite is used for geodetic triangulation and all other precise surveys whereas Wild T4 theodolite is commonly used for astronomical determination of co-ordinates and azimuth. Wild T2 and Zeiss Theo 010 are commonly used for engineering surveys.

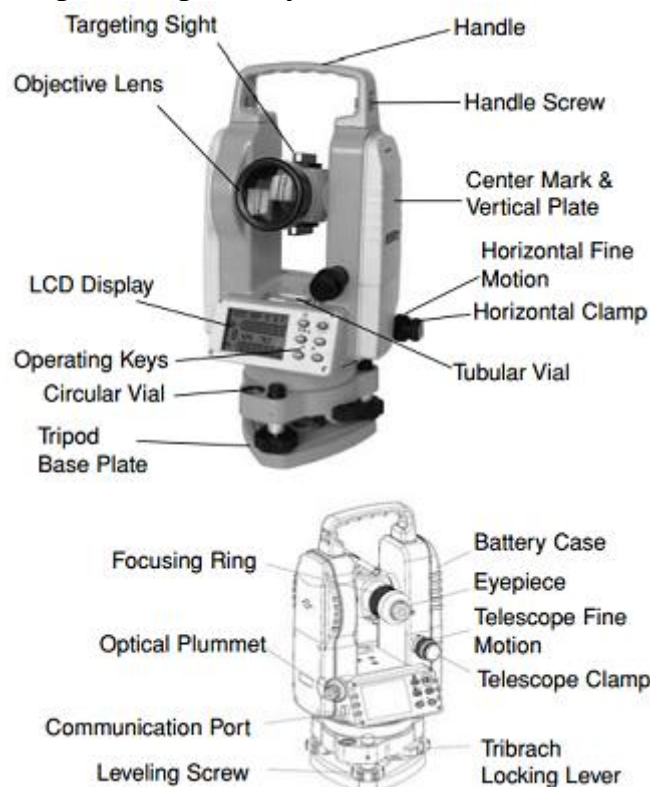

**Fig: Parts of a Theodolite**

## Electronic Theodolites:

A major change in the design of theodolites has occurred in recent years with the introduction of electronic circle reading systems to their design. The electronic theodolites are similar to micro-optic theodolites in their design and operation. However, the difference lies in the system of taking reading. Here, the observations are taken through digital readouts or displays. The commonly used displays are Light-Emitting Diodes (LED) and Liquid Crystal Displays (LCD). The direct display of angular readings eliminates the guessing and interpolations associated with the vernier scale and micrometer readings in other theodolites. The angles can be measured to a least count of 1" with precision ranging from 0.5" to 10". One of the significant characteristics of these theodolites is that the data can be recorded in a data collector attached with the theodolite. The data can then be processed in a computer for subsequent analyses. The theodolites have a zero set button for initial setting of the readings. Once attached with EDM, it can then be used as a Total Station . A typical electronic theodolite is shown in Figure.



**Fig :** An Electronic Theodolite

## Working of Micro-optic and Electronic Theodolites

The working of these theodolites is more or less similar to that of a vernier theodolite. The major difference is in the centering procedure, which is through optical plummet instead of the conventional plumb bob centering. For an easy and quick set up, following steps may be followed :

- a. Place the instrument over the point with the tripod plate as horizontal as possible.
- b. From a distance of 1 to 2 meter, check if the instrument appears to be set over the station. If not, adjust the location and check again. Move in the direction 90o to the original setting and repeat the steps.
- c. Through the optical plummet, look the station mark and then firmly push in the tripod legs into the ground.
- d. Manipulate the levelling screws while simultaneously looking through the optical plummet until its cross hair is exactly over the station mark.
- e. Level the theodolite with the circular bubble in the usual fashion.

- f. Look into the optical plummet to confirm that its cross hair is quite close to the station mark.
- g. The circular bubble can now be brought into centre by turning one or more levelling screws.
- h. The tripod clamp is now loosened to slide the instrument on the flat tripod top till the optical plummet cross hair is exactly centered over the station mark.
- i. The instrument can now be precisely levelled using longitudinal bubble in the usual fashion as we do in vernier theodolite.
- j. Start measuring the horizontal and vertical angles.

The instrument can be used for various surveying operations such as laying off angles, prolonging a straight line, balancing in, intersection of two lines etc.

### **ELECTRONIC DISTANCE MEASUREMENT (EDM)**

For providing precise horizontal control using trilateration, it is necessary that the distances be measured as accurately as possible. The advent of EDM has made this possible. The EDM was first introduced in the late 1950. Since then, many refinements to these equipment have been made. The earlier EDMs were very big, heavy and expensive. With the advancements in electronic and computer technologies, these have become smaller, simpler and less expensive. The EDMs come in two parts : the instrument and the reflector.

#### **The Instrument**

The EDMs are generally of two types : electro-optical systems and electronic systems. The electro-optical systems use either light and laser waves or infrared waves whereas electronic systems use microwaves. The microwave systems require transmitter/receiver at both ends of the line to be measured. The infrared system requires a transmitter at one end and a reflector at the other end. The microwave systems are capable of measuring distances up to a limit of 100 kms whereas the infrared EDMs come in three different ranges, long range (10-20 km), medium range (3-10 km) and short range (0.5-3 km) equipment. A typical EDM is shown in Figure.

#### **The Reflector**

The reflector is usually a prism or a set of prisms (Figure ). Generally, a cube corner prism is used that has the characteristic of reflecting light rays precisely back in the same direction as they are received. This means that even if the prism is somewhat misaligned with respect to the EDM, it can still be effective. These prisms can be mounted on a tripod or a pole held vertical on the point. For higher accuracy, the prisms should be mounted on a tripod. The height of the prism is normally set equal to the height of the instrument.



**Fig:** An EDM fitted on Total Station



**Fig:** Reflector used with EDM and Total Station

Recently, some EDMs have been introduced that can measure the distances without reflectors. In these situations, the surface itself behaves as a reflector. However, the EDMs without reflectors can only be used for the measurement of shorter distances within 1 km and also with reduced accuracy.

The EDM when mounted on a precise theodolite can be used to determine both slope and vertical distances. This arrangement has given rise to another category of surveying instrument known as Total Station or Field Station.

### **Principle of EDM**

The EDM systems are based on the principle of distance travelled between the transmitted wave from one end and its reception at the other end. Thus, the basic relationship between time, speed and distance is applied. The instrument transmitting the infrared or microwaves is kept at one end whereas the reflector is kept at the other end. The instrument sends the waves, which are reflected by the reflector to be received by the instrument. Figure 5.3 shows a wave of wavelength  $\lambda$  travelling along the  $x$ -axis with a velocity  $v$ . The relationship between wavelength ( $\lambda$ ), frequency ( $f$ ) and velocity ( $v$ ) can be given as,

$$\lambda = \frac{v}{f}$$

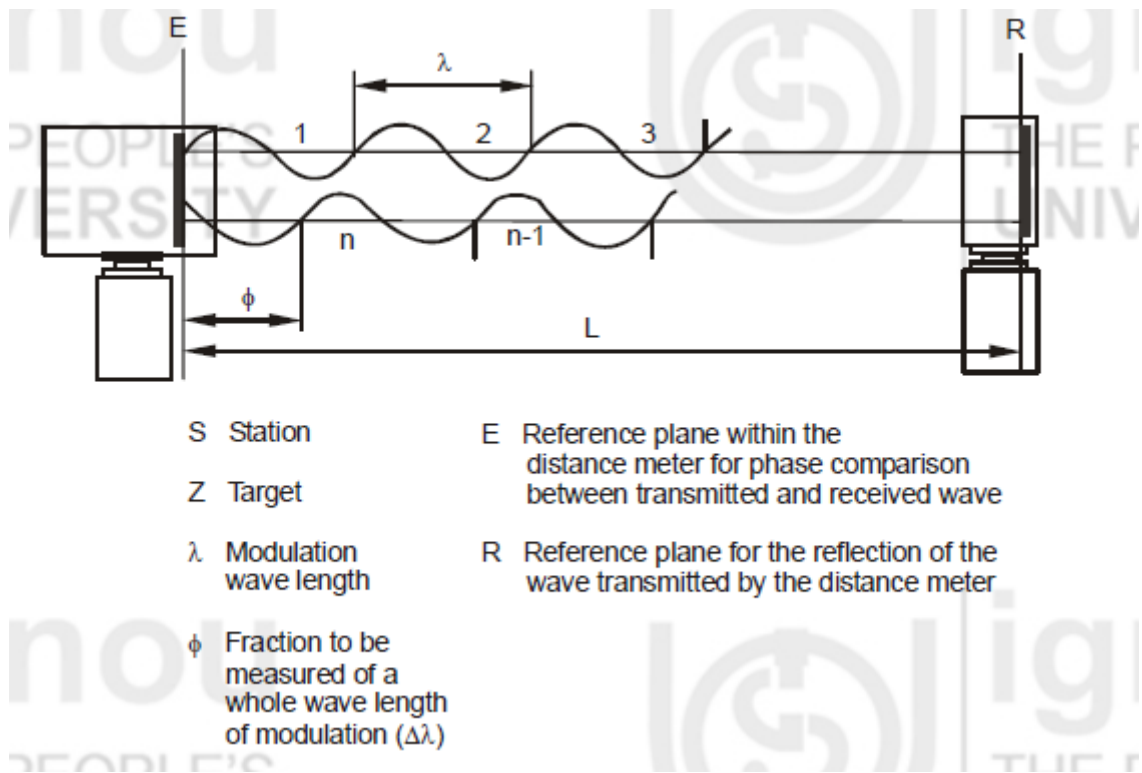

**Fig :** Principle of EDM Measurement

In Figure , a modulated wave transmitted by the instrument and its reflection back to it is shown. It can be seen that the double distance  $2L$  can be determined by knowing the total number of wavelengths plus the fraction of wavelength reaching the EDM. Thus,

$$L = \frac{(n\lambda + \phi)}{2}$$

The fraction wavelength  $\phi$  can be determined in the instrument by noting the phase delay required to precisely match the transmitted and reflected waves. The instruments are designed to determine the number of wavelengths ( $n$ ) within seconds and compute the distance in no time.

### Corrections

Since the wave travels through the atmosphere, the velocity of the wave may be affected by temperature, pressure and water vapour content. Therefore, the appropriate corrections for these must be applied. Normally, the provision for these corrections is made in the instruments themselves by supplying the required values of the prevailing atmospheric quantities on the day of measurement.

Alternatively, these corrections can be applied manually by looking at the charts and graphs (showing the relationships between the quantities and the corrections) provided by the manufacturers of the instrument. It may, however, be mentioned that the effect of atmosphere is more pronounced in long distances of the order of kilometers. For short distances, less than a kilometer, the atmospheric corrections are less significant and may not be required.

### Working of EDM

Before using EDM in the field, these are normally checked for their accuracy and proper adjustment. EDM instruments are calibrated against the known distances. The zero error (distances between electronic and physical centre), if



any, is determined. This activity requires several measurements on different known lengths.

Once zero error is found out, the measurements can be taken. The typical operation of any EDM involves four basic steps of setting up, bisection, observing and recording.

### **Setting Up**

The EDM instrument is first inserted into the tribrach on the tripod, which is centered exactly over the station mark through optical plummet. Reflector is set over the other point of the line whose distance is to be measured. The power of the instrument is turned on and certain initial checks are made. For example, to examine proper working of the battery and the display.

### **Bisection**

The instrument is unclamped to bisect the reflector through the built-in sighting device. There are horizontal and vertical tangent motion screws for exact bisection of the reflector.

### **Observing**

The distances are measured by simply pressing the measurement key and waiting for a few seconds. The result appears on the LCD panels. If there is no display, the user should check the previous steps. Repeated measurements are often made to observe the distances with more precision by pressing the repeat mode key. Some of the corrections normally applied on the distances measured by EDM instruments are atmospheric and zero error correction, slope to horizontal distance conversion etc. Since the measurements obtained are slope distances, some EDM have built-in calculators to compute horizontal and vertical distances if the vertical angles are fed manually through the keypad.

### **Recording**

These days, all the EDMs are supplied with an electronic field book wherein the measurements can be recorded directly or by manual entry. The observations must be accompanied with all relevant atmospheric and instrumental correction data.

### **Accuracy Considerations**

In general, the accuracy of an EDM is expressed in terms of a constant instrumental error and a measuring error proportional to the distance being measured. Thus, an accuracy value of  $\pm (5 \text{ mm} + 5 \text{ parts per million (ppm)})$  signifies that 5 mm is the constant instrument error (independent of the length of the measurement), whereas the 5 ppm (5 mm/km) represents the distance related error. For example, if the distance to be measured is 10 km then the total error in the measurement shall be  $5\text{mm} + (5 \times 10) \text{ mm}$  which works out to be 55 mm or 5.5 cm. This is equivalent to an accuracy of 55 in 1,00,00,000 (or 1 in 181818). Now-a-days, EDM equipment are being manufactured by various companies throughout the world. The specifications of these vary in terms of the distance range and accuracy. A list of some EDMs manufactured by Sokkia Geosystems (earlier Wild) with their salient features is given in Table .

**Table : Some Models of EDM**

Sl. No.	Name	Distance Range	Accuracy
1.	DI1001	800 m with 1 prism	$\pm (5 \text{ mm} + 5 \text{ ppm})$
2.	DI1600	2500 m with 1 prism	$\pm (3 \text{ mm} + 2 \text{ ppm})$
3.	DI2002	2500 m with 1 prism	$\pm (1 \text{ mm} + 1 \text{ ppm})$
4.	DI300S	19 km	$\pm (3 \text{ mm} + 1 \text{ ppm})$

The criterion for the selection of an EDM depends upon the range and accuracy achievable. The instrument capable of taking measurements to an error of 1 to 2 ppm is the best suited for geodetic control establishment. For civil engineering works, where accuracy requirement may not be high, short range EDM with 5 ppm error can be used.

**Total Station:**

In the previous sections, you have been introduced to electronic theodolites and EDMs. When these instruments are combined into one assembly, these give rise to another category of surveying instruments known as Electronic Tacheometers. These are also referred to with other names such as Total Stations and Field Stations.

**Concept of Total Station**

The basic idea behind the development of Total Station is the fact that the equipment can be used to perform all surveying operations in one go from a station (or point) and hence the name. Thus, a total station is an equipment that can electronically measure both angles and distances and perform limited computational tasks using an internal micro-processor such as reduction of slope to horizontal distance, computations of coordinates from a bearing and distance etc. Often, these are provided with built-in facility for atmospheric and instrumental corrections. The data are recorded by the instrument in internal memory or in external memory cards. The advantage with these cards is that these can be directly inserted into the computer for easy data transfer. Moreover, these cards come in different memory sizes and, thus, the data for many days and months can be recorded.

There are two basic designs of a Total Station : integrated design; and modular design. In integrated design (Figure ), both the electronic theodolite and the EDM are assembled in a single unit, whereas in the modular design these act as separate units. The latter arrangement is more flexible, since the theodolites and EDM units with varying precision can be combined to form a suitable design as per the requirement of the project.

One important feature of any total station is the provision of data recorder or collector in it. A data recorder is basically a hand-held computer. It can record all the measurements in suitable format and can perform some basic computations such as figure closures and adjustments. Also, many total stations can record all measurements (i.e., slope distance, horizontal and vertical angles) of a point by just pressing a button. The point number and its description may also be recorded.



**Fig:** A Total Station (Sokkia ix 500 Series)

### **Working of Total Station**

There are many surveying tasks where Total Station can be used effectively. These include preliminary control and construction surveys etc. However, these have mostly been used for topographic surveys where the three coordinates of a point (i.e., Northings, Eastings and Heights above msl) are required. Typical steps in the operation of a Total Station for a traverse computation can be listed as below.

#### **(i) Entry of Initial Data**

After switching on the equipment, at first instance, some initial data are fed to it through the controller. These data include the description of the project, date and survey team, atmospheric pressure and temperature values, prism constant, sea level, curvature and refraction corrections, choice of measurement units etc. It is likely that you may bypass feeding of certain data as the default values may themselves be sufficient.

#### **(ii) Entry of Traverse Station (Occupied Point) and Feature (Sighted Point) Code**

All the traverse stations and features to be plotted must be given a suitable coding system for their recognition. The coding system varies from one model of Total Station to the other. These codes may be entered through the keypad on most of the equipment. Some models now have the provision of bar codes to enter the codes. For the traverse station, in addition to the station codes, the data such as height of instrument, station name and number, coordinates of traverse station (forward and backward), azimuth of reference line etc. may also be entered. Similarly, for the sighted point, besides its code, the other data to be supplied are height of prism or reflector, point name and number etc.

#### **(iii) Measurement of Angles and Distances**

After entering the required data, an observer may start taking measurements using the following steps (refer Figure ) :

- (a) Centre the Total Station over the traverse station 11.
- (b) Sight at station 14, zero the horizontal circle.

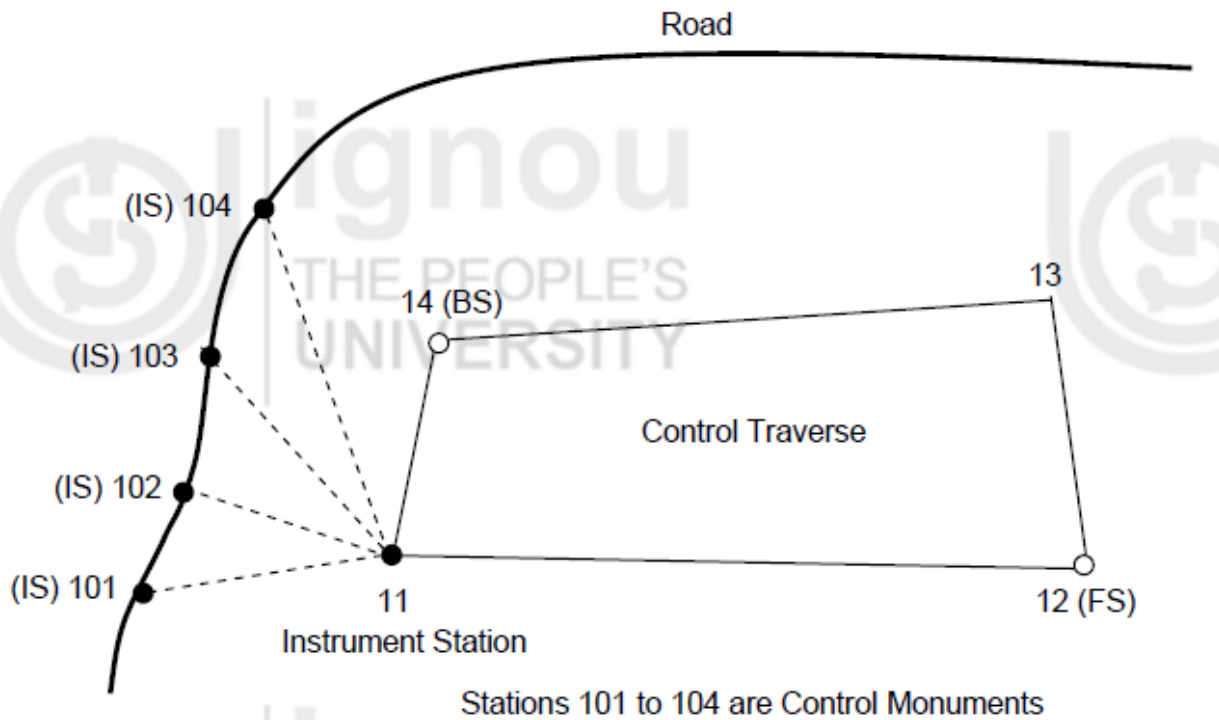

**Fig :** Sketch Showing Intermediate Road Ties to a Control Traverse

- (c) Enter code of sighted station 14.
- (d) Measure and enter the height of prism/reflector.
- (e) Press appropriate measure key as there may be different keys for different measurements such as horizontal and vertical angles, horizontal and vertical distances etc.
- (f) Press record button.
- (g) From this traverse station, any number of points signifying the topographical features such as 101, 102, 103 are sighted and their measurements recorded. For doing this, the prism mounted on a pole has to be moved to the respective points.
- (h) Once measurement and recording of all the points is completed, the Total Station is moved to the next traverse station (i.e., 12) and the procedure is repeated till all the stations are covered.

### **Transfer of Data and Its Processing**

All the models of the Total Station are supplied with software for processing the data stored in the data collector or electronic field book. The processing may require operations such as preliminary analysis, adjustments and coordinate computations. For example, to process the data from Sokkia models, the software Sokkia may be used. However, the software supplied with other model may also be used to process the data captured by Sokkia model through some manipulations. For any data processing, first the data have to be downloaded from the electronic field book to computer where the software is installed. It is possible to connect the field book directly to the computer through a cable. Otherwise, the data stored in the memory card of the field book can be inserted into appropriate slot in the computer for its transfer. The data transfer is followed by desired processing operation for the computation of coordinates of points and features.

## Plotting of Details

After processing the field data in the desired form (i.e., the coordinates), the data required for plotting may be assembled and the survey can be quickly plotted at any scale on a printer or a plotter. The symbols necessary for plotting different topographical features can be extracted from the symbol library provided in the software. Some software have the provision of generating your own symbols, if these are not available in the software.

## Accuracy Considerations

The accuracy of a Total Station is generally referred in terms of distance measuring accuracy and angle measurement accuracy. Since the distance measurement is through EDM, all the accuracy standards of EDMs apply to Total Station. Similarly, all the accuracy standards of digital theodolites apply to the angle measurement accuracy of the Total Station. A number of Total Stations are available in the market these days. Some of them (e.g., manufactured by Nikon and Leica) along with their accuracy standards are mentioned in Table .

**Table : A List of Some Total Stations**

Sl. No.	Name	Distance Range with 1 Prism	Distance Accuracy	Angular Accuracy
1.	DTM850 (Nikon)	2400 m	$\pm (2 \text{ mm} + 2 \text{ ppm})$	1''
2.	DTM550 (Nikon)	2400 m	$\pm (4 \text{ mm} + 2 \text{ ppm})$	1''
3.	DTM310 (Nikon)	1000 m	$\pm (5 \text{ mm} + 5 \text{ ppm})$	5''
4.	TCA1101 (Leica)	1000 m	$\pm (3 \text{ mm} + 1 \text{ ppm})$	1.5''
5.	TC303 (Leica)	3000 m	$\pm (2 \text{ mm} + 2 \text{ ppm})$	3''
6.	TC905 (Leica)	2500 m	$\pm (2 \text{ mm} + 2 \text{ ppm})$	2''
7.	TCA2003 (Leica)	2500 m	$\pm (1 \text{ mm} + 1 \text{ ppm})$	0.5''

## **BASICS ON GPS & DGPS AND ETS**

### **GPS: - Global Positioning**

The Global Positioning Satellite (GPS) system was established by the United States Department of Defense (DoD) to provide a real-time navigation system for the US military. Since its inception it has grown to provide not only world-wide, all-weather navigation, but precise position determination capabilities to all manner of users. The resulting precision available exceeds any previously attainable without large expenditures of time and resources.

The Global Positioning System (GPS) is a satellite-based radio-navigation system established by the U.S. Department of Defense for military positioning applications and as a by-product, has been made available to the civilian community. Navigation, surveying and integration with Geographic Information Systems (GIS) are just a few of the fields which have seen the successful application of GPS technology.

GPS is a complex system which can be used to achieve position accuracies ranging from 100 m to a few millimeters depending on the equipment used and procedures followed. In general, higher accuracies correspond with higher costs and more complex observation and processing procedures. Therefore it is important for users to understand what techniques are required to achieve desired accuracies with the minimal cost and complexity. The objective of these guidelines is to provide the background and procedural information needed to effectively apply GPS technology.

### **Definition of GPS:**

- The GPS is a satellite-based navigation system made up of a network of 24 satellites placed into orbit by the U.S. Department of Defense. GPS was originally intended for military applications, but in the 1980s, the government made the system available for civilian use. GPS works in any weather conditions, anywhere in the world, 24 hours a day. There are no subscription fees or setup charges to use GPS.
- The global positioning system is a satellite-based navigation system consisting of a network of 24 orbiting satellites that are eleven thousand nautical miles in space and in six different orbital paths. The satellites are constantly moving, making two complete orbits around the Earth in 24 hours i.e. 2.6 kilometers per second.
- The Global Positioning System (GPS), originally NAVSTAR GPS, is a satellite-based radio navigation system owned by the United States government and operated by the United States Space Force (USSF). It is one of the Global Navigation Satellite Systems (GNSS) that provides geo location and time information to a GPS receiver anywhere on or near the Earth where there is an unobstructed line of sight to four or more GPS satellites. Obstacles such as mountains and buildings block the relatively weak GPS signals.
- The Global Positioning System is a space-based navigation and positioning system that was designed by the U.S. Military to allow a single soldier or group of soldiers to autonomously determine their position to within 10 to 20 meters of truth. The concept of autonomy was important in that it was necessary to design a system that allowed the soldier to be able to determine where they were without any other radio (or otherwise) communications.

- The GPS project was started by the U.S. Department of Defense in 1973, with the first prototype spacecraft launched in 1978 and the full constellation of 24 satellites operational in 1993. Originally limited to use by the United States military, civilian use was allowed from the 1980s following an executive order from President Ronald Reagan. The system provides critical capabilities to military, civil and commercial users around the world. It is maintained by the United States government and is freely accessible to anyone with a GPS receiver.

### **DOP (Dilution of Precision)**

DOP is a value that shows the degree of degradation of the GPS positioning accuracy. The smaller the value is, the higher the positioning accuracy is. This value depends upon the positions of the GPS satellites tracked for positioning. If the tracked satellites spread evenly over the earth, the positioning accuracy would become higher, and if the positions of tracked satellites are disproportionate, the positioning accuracy would become lower.

### **Working Principle of GPS, GPS Signals**

The Global Positioning System consists of three major segments: the Space Segment, the Control Segment, and the User Segment. The space and control segments are operated by the United States Military and administered by the U.S. Space Command of the U.S. Air Force. Basically, the control segment maintains the integrity of both the satellites and the data that they transmit. The space segment is composed of the constellation of satellites as a whole that are currently in orbit, including operational, backup and inoperable units. The user segment is simply all of the end users who have purchased any one of a variety of commercially available receivers. While the user segment obviously includes military users, this book will concentrate on the civilian uses only. Each of the segments will be examined more closely in the following pages.

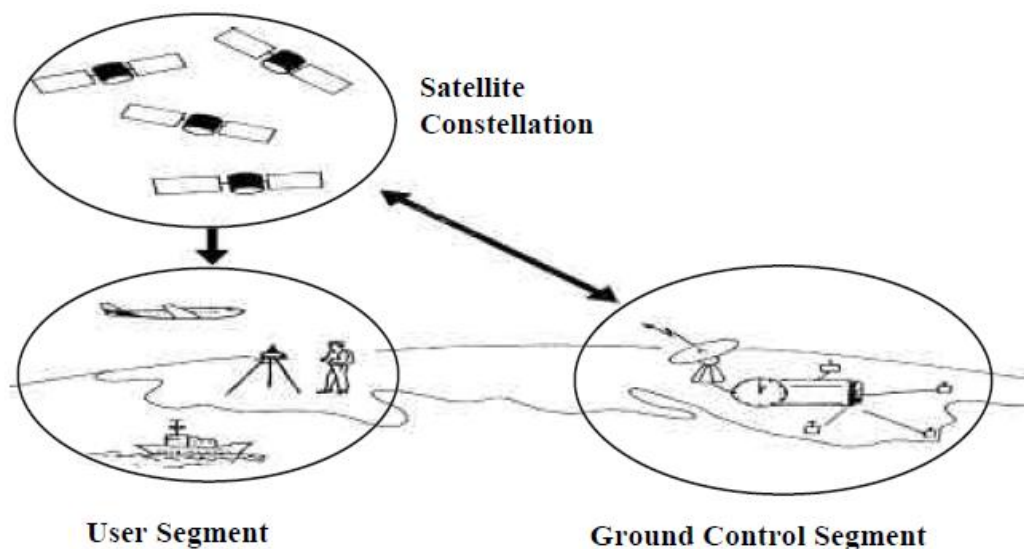

**Fig:** Three Segments of GPS

### **The Control Segment**

- The control segment of the Global Positioning System consists of one Master Control Station (MCS) located at Falcon Air Force Base in Colorado Springs, Colorado, and four unmanned monitor stations located

strategically around the world e.g. Hawaii Monitor Station, Ascension Monitor Station, Diego Garcia Monitor Station, Kwajalein Monitor Station.

- In addition, the Air Force maintains three primary ground antennas, located more or less equidistant around the equator.
- Observation and controlling the satellite system regularly.
- To check the satellite functions and its accurate position in the space.
- To determine the time of GPS.
- Update periodically navigation messages for each satellite.
- In the event of some catastrophic failure, there are also two backup Master Control Stations, one located in Sunnyvale, California, and the other in Rockville, Maryland.
- The unmanned monitor stations passively track all GPS satellites visible to them at any given moment, collecting signal (ranging) data from each. This information is then passed on to the Master Control Station at Colorado Springs via the secure DSCS (Defense Satellite Communication System) where the satellite position (“ephemeris”) and clock-timing data (more about these later) are estimated and predicted.
- The Master Control Station then periodically sends the corrected position and clock-timing data to the appropriate ground antennas which then upload those data to each of the satellites.
- Finally, the satellites use that corrected information in their data transmissions down to the end user.
- This sequence of events occurs every few hours for each of the satellites to help insure that any possibility of error creeping into the satellite positions or their clocks is minimized.
- The CS is responsible for maintaining the satellites and their proper functioning. This includes maintaining the satellites in their proper orbital positions (called station keeping) and monitoring satellite subsystem health and status.
- The CS also monitors the satellite solar arrays, battery power levels, and propellant levels used for maneuvers. Furthermore, the CS activates spare satellites (if available) to maintain system availability.
- The CS updates each satellite’s clock, ephemeris, and almanac and other indicators in the navigation message at least once per day. Updates are more frequently scheduled when improved navigation accuracies are required. (Frequent clock and ephemeris updates result in reducing the space and control contributions to range measurement error.
- Depending on the satellite block, the navigation message data can be stored for a minimum of 14 days to a maximum of a 210-day duration in intervals of 4 hours or 6 hours for uploads as infrequent as once per two weeks and intervals of greater than 6 hours in the event that an upload cannot be provided for over 2 weeks.
- Furthermore, the CS resolves satellite anomalies, controls SA and AS, and collects pseudo range and carrier phase measurements at the remote monitor stations to determine satellite clock corrections, almanac, and ephemeris. To accomplish these functions, the CS is comprised of three



different physical components: the master control station (MCS), monitor stations, and the ground antennas.

- Newly added control stations after 2005 are Washington DC England, Ecuador, Argentina, Bahrain and Australia.
- These Monitor stations measure signals from the SVs, which are incorporated into orbital models for each satellites.
- Master stations collect the data about the satellites of this system continuously from the other tracking stations. MCS process the tracking data for computation of satellite ephemerides (or co-ordinate) & satellite clock parameters.
- The Master control station uploads ephemeris and clock data to the SVs. The SVs then send subsets of the orbital ephemeris data to GPS receivers over radio signals. The MCS also monitor the position of satellites at any instant of time, the functional capacity of the satellites & variation of the navigation data. The computation of satellite's Ephemeris & Clock errors are most important tasks of control stations, as both variables are important to get high accuracy.

Peter H. Dana 5/27/95

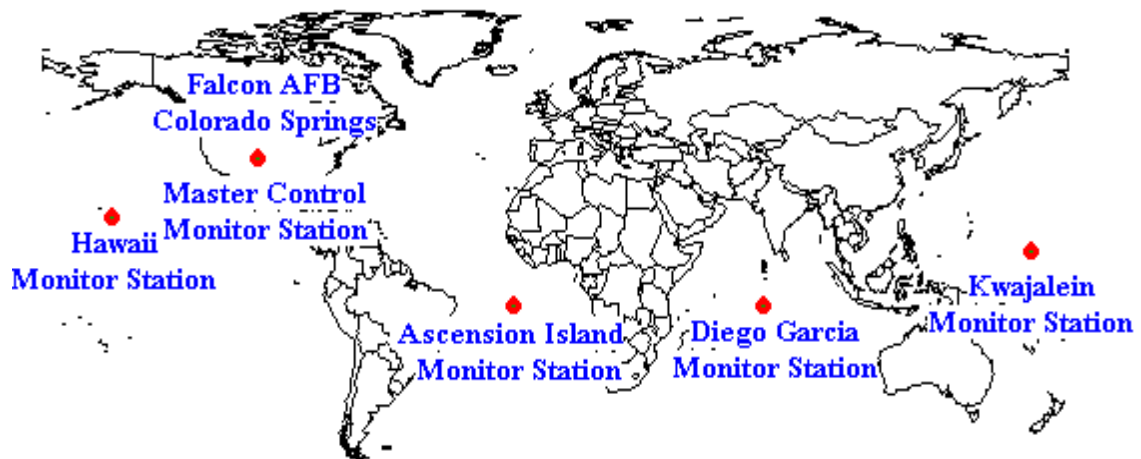

Global Positioning System (GPS) Master Control and Monitor Station Network

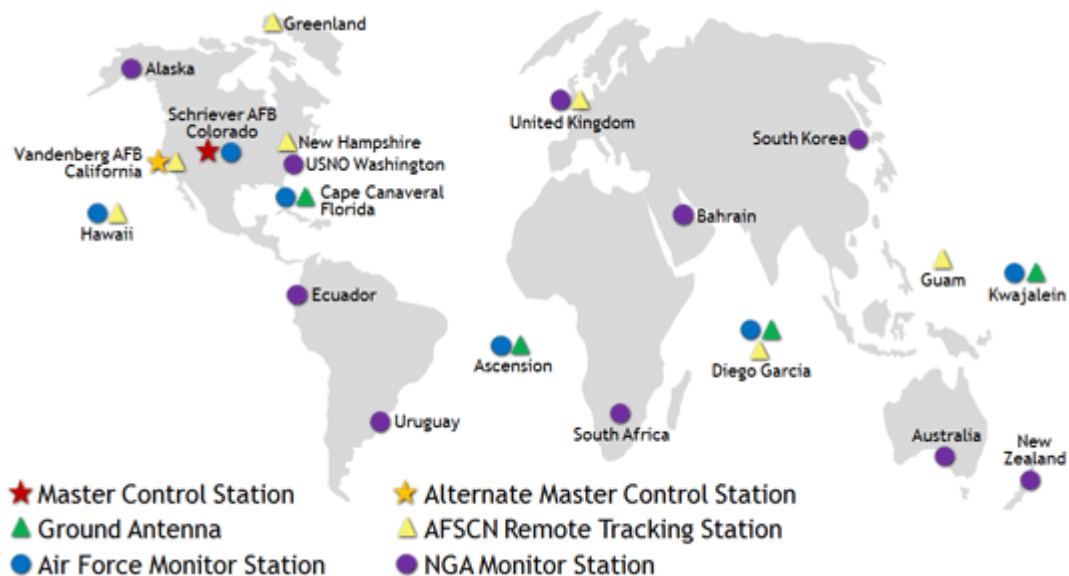

Fig. GPS Control Segment

## **The Space Segment**

- The space segment consists of the complete constellation of orbiting NAVSTAR GPS satellites. The current satellites are manufactured by Rockwell International and cost approximately \$40 million each.
- To each satellite must be added the cost of the launch vehicle itself which may be as much as \$100 million. To date, the complete system has cost approximately \$10 billion. Each satellite weights approximately 900 kilograms and is about five meters wide with the solar panels fully extended. There were 11 Block I prototype satellites launched (10 successfully), followed by 24 Block II production units. Currently, only one of the Blocks I satellites is still operational, while four Block II backups remain in ground storage. The base size of the constellation includes 21 operational satellites with three orbiting backups, for a total of 24. They are located in six orbits at approximately 20,200 kilometers altitude.
- Each of the six orbits is inclined 55 degrees up from the equator, and is spaced 60 degrees apart, with four satellites located in each orbit. The orbital period is 12 hours, meaning that each satellite completes two full orbits each 24-hour day.
- The space segment is the constellation of satellites from which users make ranging measurements. The SVs (i.e., satellites) transmit a PRN-coded signal from which the ranging measurements are made. This concept makes GPS a passive system for the user with signals only being transmitted and the user passively receiving the signals.
- The Space Segment of the system consists of the GPS satellites. These Space Vehicles (SVs) send radio signals from space. The Space Segments - consists of the group of minimum 24 Satellites & the signals -that are broadcast by them, which allow user to determine position velocity & time. The basic functions of satellites are - To receive & store data uploaded by Control Segment. Maintain accurate time by means of on board ATOMIC CLOCKS & Transmit information & signals to users on TWO L- band frequencies. Out of 52 constellations of GPS Satellites, the 11 were launched as an experimental satellite in Feb 1978 under so-called Block 1 Phase, Block 2 & Block 2 A were launched from 1989 onwards. Full operational capability was declared on 17 July in 1995.
- Currently 12 of these satellites are re-designed as the part of GPS Modernisation Programme.



### ***GPS Satellite Details***

- ❖ *Name: NAVSTAR (The Navigation Satellite Timing and Ranging-USA)*
- ❖ *Galaxy: consist of 24 satellites.*
- ❖ *Manufacture: Rockwell International*
- ❖ *Altitude: 20200 km*
- ❖ *Weight: 845 kg*
- ❖ *Number of path or orbit: 6*
- ❖ *Number of satellite per path: 4*
- ❖ *Orbital inclination: 55 degree to equatorial plane*
- ❖ *Orbital spacing: 60 degree (360/6)*
- ❖ *Orbital period: 12 hours*
- ❖ *Planned life span: 7.5 years*

### **The User Segment**

- Information that comes from space and sends to satellites is the most important part of GPS.
- The part that does this work is User Segment. It has the GPS receiver section.
- GPS collect and stored the all information that has come from space. For this, 4 satellites are required.
- The GPS user segment consists of the GPS receivers and the user community. GPS receivers convert SV signals into position, velocity and time estimates. Four satellites are required to compute the four dimensions of X (latitude), Y (longitude), Z (altitude) and T (time). GPS receivers are used for navigation, positioning, time dissemination and other research
- The user receiving equipment comprises the user segment. Each set of equipment is typically referred to as a GPS receiver, which processes the L-band signals transmitted from the satellites to determine user PVT (Position, Velocity and Time).
- While PVT determination is the most common use, receivers are designed for other applications, such as computing user platform attitude (i.e., heading, pitch, and roll) or as a timing source.

- Navigation in three dimensions is the primary function of GPS. Navigation receivers are made for aircraft, ships, and ground vehicles and for hand carrying by individuals. Precise positioning is possible using GPS receivers at reference locations providing corrections and relative positioning, geodetic control and plate tectonic studies are example.
- Time and frequency dissemination, based on the precise clocks on board the SVs and controlled by the monitor stations, is another use for GPS, Astronomical observatories, telecommunications facilities, and laboratory standards can be set to precise time signals or controlled to accurate frequencies by special purpose GPS receivers. Research projects have used GPS signals to measure atmospheric parameters.

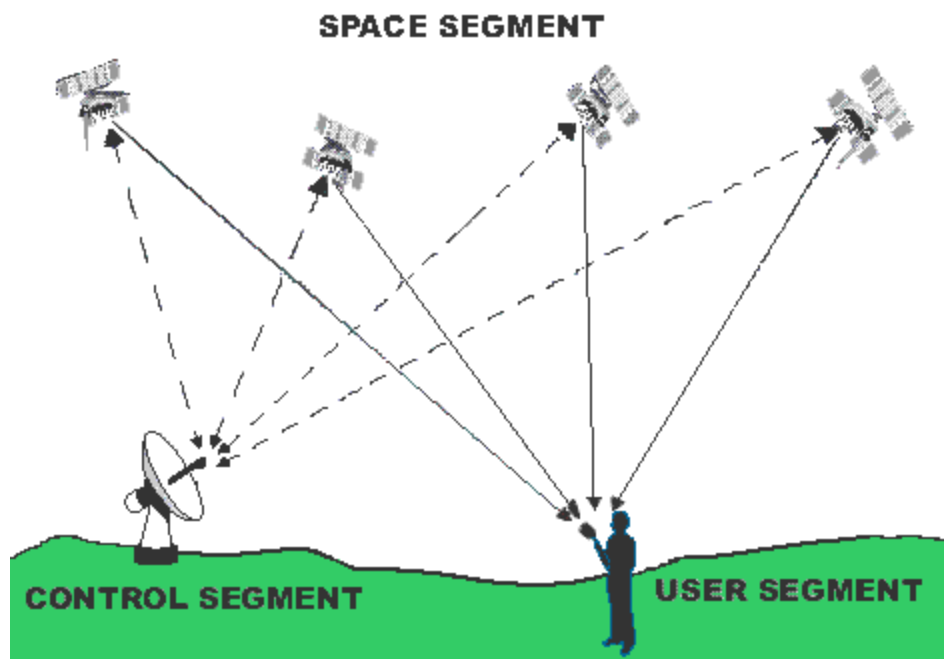

### Working Functions of GPS

Generally the functions of a GPS are completed with 5 steps.

#### Step -1: Triangulating from Satellites:

- GPS operation is based on the concept of ranging and Trilateration from a group of satellites, which act as precise reference points. Each satellite broadcasts a Navigation Message that contains the following information;
- A pseudo-random code called a Course Acquisition (CA) code, which contains orbital information about the entire satellite constellation (Almanac).
- Detail of the individual satellite's position (Ephemeris) that includes information used to correct the orbital data of satellites caused by small disturbances.
- The GPS system time, derived from an atomic clock installed on the satellite, with clock correction parameters for the correction of satellite time due to differences between UTC and GPS time (the occasional 'leap' second added to a year) and delays (predicted by a mathematical ionospheric model) caused by the signal travelling through the ionosphere.
- A GPS health message that is used to exclude unhealthy satellites from the position solution.

- The GPS receiver in the aircraft takes 12.5 minutes to receive all of the data frames in the navigational message. Once obtained, the receiver starts to match each satellite's CA code with an identical copy of the code contained in the receiver's database. By shifting its copy of the satellite's code, in a matching process, and by comparing this shift with its internal clock, the receiver can calculate how long it took the signal to travel from the satellite to the receiver. The distance derived from this method of computing distance is called a Pseudo-range because it is not a direct measure of distance, but a measurement based on time. Pseudo-range is subject to several error sources, including atmospheric delays and multipath errors, but also due to the initial differences between the GPS receiver and satellite time references.
- Using a process called Trilateration, the GPS receiver then mathematically determines its position by using the calculated pseudo-ranges and the satellite position information that has been supplied by the satellites. GPS\_3D-Trilateration.
- If only one satellite is visible, position location is impossible as the receiver location can be anywhere on the surface of a sphere with the satellite at its centre.
- If two satellites are visible the receiver location can be anywhere on a circle where the surfaces of the two spheres intercept. So position location is also impossible.
- When a third satellite becomes visible, the GPS receiver can establish its position as being at one of two points on the previously derived circle where the third satellite sphere intercepts it. So, whilst position fixing is possible, it is unreliable unless it is assumed that the receiver is at sea level on the surface of the Earth, because it is almost certain that only one of the two derived points would be near the surface of the Earth. So fixing is possible, but only in two dimensions (2D fixing): in latitude and longitude.
- With at least four satellites visible, and their alignment good, the four spheres will intersect at only one point in space, so receiver position can be accurately fixed in three dimensions (3D fixing): in latitude, longitude and altitude.
- With five satellites visible, it is possible for the system to automatically detect an erroneous signal.
- With six satellites visible, it is possible for the system to automatically detect an erroneous signal, identify which satellite is responsible and exclude it from consideration.
- Altitudes derived from GPS positions are known as Geodetic altitudes and were not initially used for aircraft navigation; PBN requires that they, and the navigational information presented by the system, are based on the World Geodetic System established in 1984, the WGS 84 coordinate system.
- As the GPS satellites provide a very accurate time reference as well as precise 3D position fixes, they can also calculate and provide accurate speed data.

## Step-2: Measuring distance from a Satellite:

- Normally distances are calculated on GPS is based on signals of a Satellite ranging.
- The easy formula to calculate the distance is:  
Distance (d) = Speed of satellite ranging ( $3 \times 10^8$  m/second) x time  
Time ( $\Delta t$ ) =  $t_2 - t_1$  where,  $t_1$  = sending time,  $t_2$  = receiving time

## Step- 3: Getting Perfect Timing:

- If travel time measures through the radio signal are the basics of GPS, then stopwatch are very working instrument in this case. If their time is stopped for one thousandths of a second, then it will wrong at 200 miles.
- In terms of Satellites, timing is perfect because the Atomic clock is the compulsory element of Satellite systems.
- The key to accurate scheduling is to measure the distance to an extra satellite.
- If the three exact measurements can identify the three-dimensional position, then the fourth incorrect measure does the same thing.

## Step-4: Knowing where a Satellite is in Space:

- We assume that we know the exact position of Satellites, for which we can used that satellites as a reference point.
- But how can we know that exactly where they are? After all, they float in the space of 11,000 miles.

## Step-5: Correcting Errors:

- So far, the calculation we are pointing to a GPS, that is sporadically. As if the whole thing was happening in a vacuum.
- But in reality, there are a lot of things which can be disrupt the GPS signals. To get the accurate results, this error likely to be corrected.
- For example, the ionosphere and atmosphere may be a reason for delay the whole function. Some error can be factored out by using arithmetic calculation and model.
- The relative position of the satellites in the sky can give rise to other errors.

## Signals of GPS

GPS system sends their information through microwave signal. The signal systems are as below:

### Pseudo Random Code (PRC):

- It is the prime part of GPS.
- It physically complicated digital number or complicated sequence of 'on' and 'off' pulse.
- There are 2 types of PRC signals generally found.
  - ❖ *Coarse Acquisition Code (C/A)*: (a) This contains L1 signals. (b) It repeats every 1023 bits & modulates at a 1 MHz rate. (c) C/A code is the basis for civilian GPS uses.
  - ❖ *Precise Code (P)*: (a) Modulate both L1 & L2 carries at a 10 MHz rate. (b) Used for Military purpose. (c) It is more complicated than C/A code.

There are 2 types of Signals: L1 & L2

- ❖ **L1 carries:** (a) L1 carries 1575.42 MHz. (b) L1 carries both the status message and a pseudo random code for timing.
- ❖ **L2 carries:** (a) L2 carries 1227.60 MHz. (b) Use for the more precise military pseudo random code.

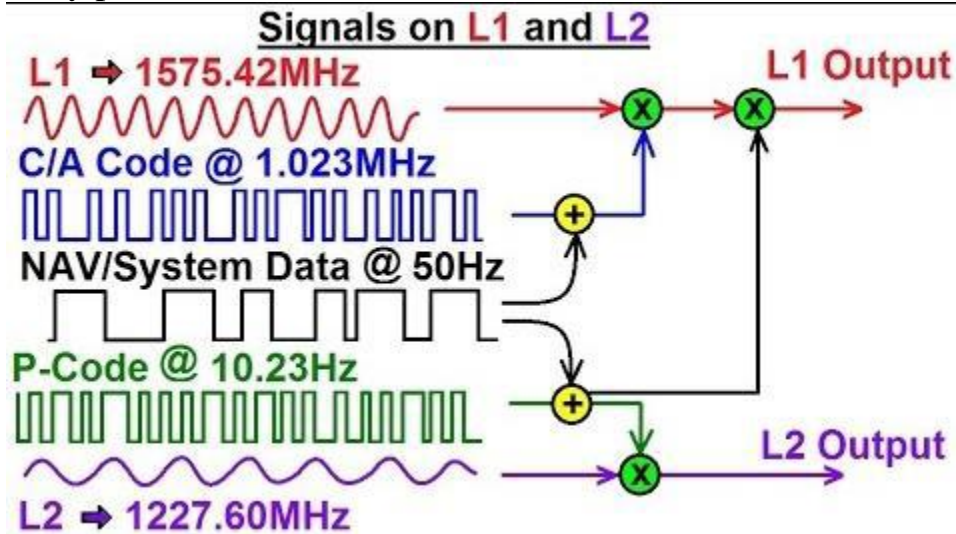

## Measurement of Errors of GPS

There are a number of sources of error that corrupt these measurements. An examination of these error sources is presented within this section.

### 1. Satellite Clock Error

The satellites contain atomic clocks that control all on board timing operations, including broadcast signal generation. Although these clocks are highly stable, the clock correction fields in the navigation data message are sized such that the deviation between SV time and GPS time may be as large as 1 ms. (An offset of 1 ms translates to a 300-km pseudo range error.) The MCS determines and transmits clock correction parameters to the satellites for rebroadcast in the navigation message. These correction parameters are implemented by the receiver using the second-order polynomial since these parameters are computed using a curve-fit to predicted estimates of the actual satellite clock errors, some residual error remains. This residual clock error,  $\delta t$ , results in ranging errors that typically vary from 0.3–4m, depending on the type of satellite and age of the broadcast data. Range errors due to residual clock errors are generally the smallest following a control segment uploads to a satellite, and they slowly degrade over time until the next upload (typically daily). At zero age of data (ZAOD), clock errors for a typical satellite are on the order of 0.8m. Errors 24 hours after an upload are generally within the range of 1–4m. It is expected that residual clock errors will continue to decrease as newer satellites are launched with better performing clocks and as improvements are made to the control segment. Errors were observed to be statistically independent from satellite to satellite with significant correlation over time.

### 2. Ephemeris Error

Estimates of ephemerides for all satellites are computed and uplinked to the satellites with other navigation data message parameters for rebroadcast to the user. As in the case of the satellite clock corrections, these corrections are generated using a curve fit of the control segment's best prediction of each satellite's position at the time of upload. The residual satellite position error is a

vector with typical magnitudes in the range of 1–6m. The effective pseudo range and carrier-phase errors due to ephemeris prediction errors can be computed by projecting the satellite position error vector onto the satellite-to-user LOS vector. Ephemeris errors are generally smallest in the radial (from the satellite toward the center of the Earth) direction. The components of ephemeris errors in the along-track (the instantaneous direction of travel of the satellite) and cross track (perpendicular to the along-track and radial) directions are much larger. Along-track and cross-track components are more difficult for the control segment to observe through its monitors on the surface of the Earth, since these components do not project significantly onto LOSs toward the Earth. Fortunately, the user does not experience large measurement errors due to the largest ephemeris error components for the same reason.

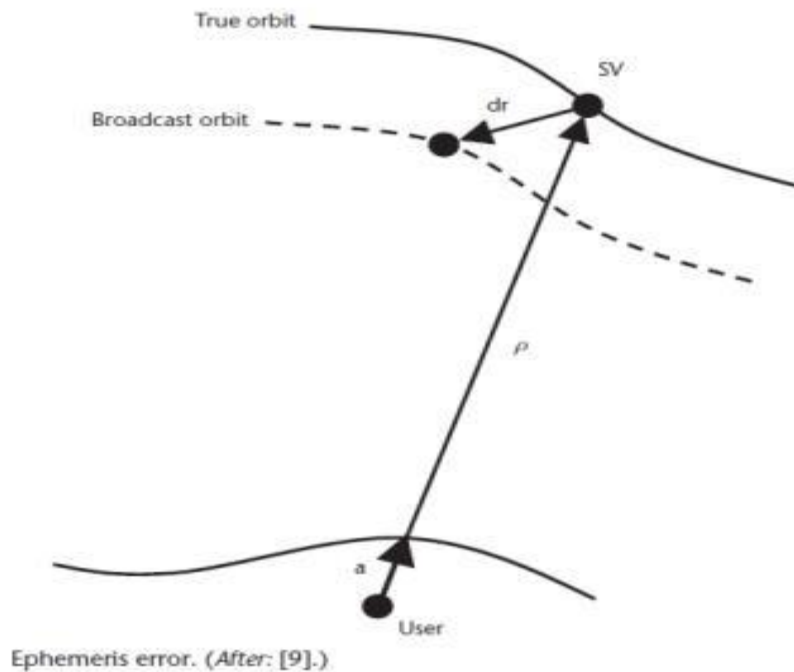

### 3. Relativistic Effects

Both Einstein's general and special theories of relativity are factors in the pseudo range and carrier-phase measurement process. The need for Special Relativity (SR) relativistic corrections arises any time the signal source (in this case, GPS satellites) or the signal receiver (GPS receiver) is moving with respect to the chosen isotropic light speed frame, which in the GPS system is the ECI frame. The need for general relativity (GR) relativistic corrections arises any time the signal source and signal receiver are located at different gravitational potentials. The satellite clock is affected by both SR and GR. In order to compensate for both of these effects, the satellite clock frequency is adjusted to 10.22999999543 MHz prior to launch. The frequency observed by the user at sea level will be 10.23 MHz; hence, the user does not have to correct for this effect. The user does have to make a correction for another relativistic periodic effect that arises because of the slight eccentricity of the satellite orbit. Exactly half of the periodic effect is caused by the periodic change in the speed of the satellite relative to the ECI frame and half is caused by the satellite's periodic change in its gravitational potential. Due to rotation of the Earth during the time of signal transmission, a relativistic error is introduced, known as the **Sagnac Effect**, when computations for the satellite positions are made in an ECEF coordinate system.



During the propagation time of the SV signal transmission, a clock on the surface of the Earth will experience a finite rotation with respect to an ECI coordinate system. Figure illustrates clearly, if the user experiences a net rotation away from the SV, the propagation time will increase, and vice versa. If left uncorrected, the Sagnac Effect can lead to position errors on the order of 30m. Corrections for the Sagnac Effect are often referred to as Earth rotation corrections.

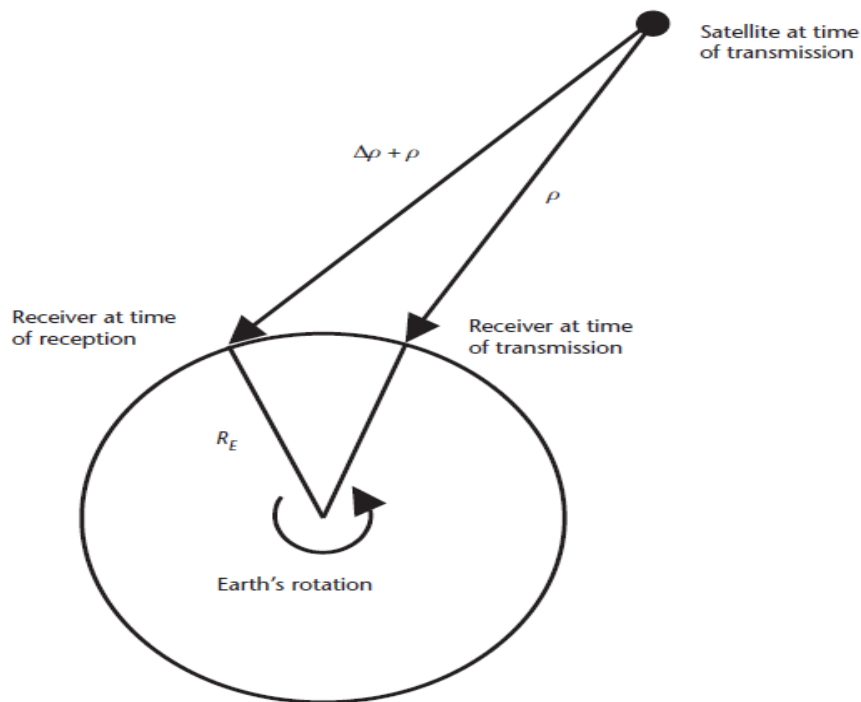

3 The Sagnac effect.

#### 4. Atmospheric Effects

The propagation speed of a wave in a medium can be expressed in terms of the index of refraction for the medium. The index of refraction is defined as the ratio of the wave's propagation speed in free space to that in the medium by the formula  $n = c/v$  Where  $c$  is the speed of light equal to 299,792,458 m/s as defined within the WGS-84 system. The medium is dispersive if the propagation speed (or, equivalently, the index of refraction) is a function of the wave's frequency.

##### 4.1 Ionospheric Effects

The ionosphere is a dispersive medium located primarily in the region of the atmosphere between about 70 km and 1,000 km above the Earth's surface. Within this region, ultraviolet rays from the sun ionize a portion of gas molecules and release free electrons. These free electrons influence electromagnetic wave propagation, including the GPS satellite signal broadcasts.

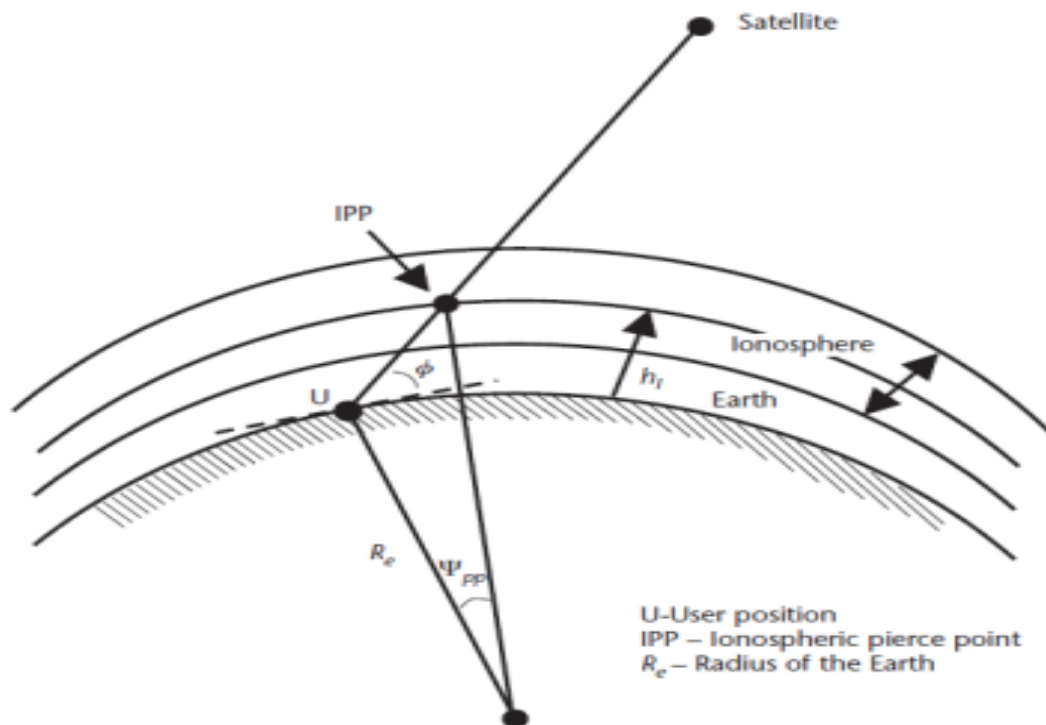

↓ Ionospheric modeling geometry.

## 4.2 Tropospheric Delay

The troposphere is the lower part of the atmosphere that is non dispersive for frequencies up to 15 GHz. Within this medium, the phase and group velocities associated with the GPS carrier and signal information (PRN code and navigation data) on both L1 and L2 are equally delayed with respect to free-space propagation. This delay is a function of the tropospheric refractive index, which is dependent on the local temperature, pressure, and relative humidity. Left uncompensated, the range equivalent of this delay can vary from about 2.4m for a satellite at the zenith and the user at sea level to about 25m for a satellite at an elevation angle of approximately  $5^\circ$ .

## 5. Receiver Noise and Resolution

Measurement errors are also induced by the receiver tracking loops. In terms of the DLL, dominant sources of pseudo range measurement error (excluding multipath) are thermal noise jitter and the effects of interference. The C/A code composite receiver noise and resolution error contribution will be slightly larger than that for P(Y) code because the C/A code signal has a smaller RMS bandwidth than the P(Y) code. Typical modern receiver  $1\sigma$  values for the noise and resolution error are on the order of a decimeter or less in nominal conditions (i.e., without external interference) and negligible compared to errors induced by multipath. Receiver noise and resolution errors affect carrier phase measurements made by a PLL.

## 6. Multipath and Shadowing Effects

One of the most significant errors incurred in the receiver measurement process is multipath. Multipath errors vary significantly in magnitude depending on the environment within which the receiver is located, satellite elevation angle, receiver signal processing, antenna gain pattern, and signal characteristics.

## **7. Hardware Bias Errors**

### **7.1 Satellite Biases**

Upon signal transmission, the GPS signals on each carrier frequency and among frequencies are imperfectly synchronized due to the different digital and analog signal paths corresponding to each signal. The timing bias between the L1 and L2 P(Y) code signals is inconsequential for most dual-frequency users since the broadcast clock corrections compensate for this bias under the presumption that the user is combining L1 and L2 pseudo range measurements via the Ionospheric-free pseudo range equation. Single-frequency users (L1 or L2) employing the broadcast clock corrections, however, must correct for the L1-L2 timing bias by using a broadcast correction, TGD, contained in word 7 of sub frame 1 of the GPS navigation message. The absolute value of the uncorrected L1-L2 group delay bias is specified to be less than 15 ns with random variations about the mean less than 3 ns (2 sigma). Observed values are generally less than 8 ns in magnitude. Until 1999, broadcast TGD values were derived from factory measurements. Since April 1999, the broadcast TGD values have been provided to the Air Force by JPL. At present, the accuracy of the broadcast values is limited by a nearly 0.5-ns message quantization error. C/A code users have an additional timing bias of the transmitted signals to account for, which is the bias between the L1 C/A code and P(Y) code signals. This bias is specified to be less than 10 ns (2 sigma). Typical observed magnitudes are less than 3 ns. Although various organizations, including JPL, routinely estimate this bias, the present GPS navigation message does not include a field for this data. Future GPS navigation messages, however, will disseminate corrections for the L1 C/A code to P(Y) code bias, as well as a number of additional group delay corrections, referred to as inter signal corrections (ISCs) that will be introduced on future satellites (i.e., Blocks IIR-M and beyond) that will broadcast the new L2C,M code, and L5 signals.

### **7.2 User Equipment Biases**

User equipment bias errors introduced by the receiver hardware are often ignored because they are relatively small in comparison to other error sources, especially when cancellation is considered. GPS signals are delayed as they travel through the antenna, analog hardware (e.g., RF and IF filters, low-noise amplifiers, and mixers) and digital processing until the point where pseudo range and carrier-phase measurements are physically made within the digital receiver channels. Although the absolute delay values for propagation from the antenna phase center until the digital channels may be quite large (over 1  $\mu$ s with long antenna-receiver cable runs or when SAW filters are employed), for similar signals on the same carrier frequency the delays experienced for the set of visible signals are nearly exactly equal. The absolute delay is important for timing applications and must be calibrated out. For many applications, however, the common delay does not affect performance, since it does not influence positioning accuracy, but rather directly appears only in the least-squares estimate of receiver clock bias.

## **8. Pseudo range Error Budgets**

Based on the earlier discussion regarding error constituents, we can develop pseudo range error budgets to aid our understanding of stand-alone GPS

accuracy. These budgets are intended to serve as guidelines for position error analyses. Position error is a function of both the pseudo range error (UERE) and user/satellite geometry (DOP).

### **Applications or Uses of GPS:**

The United States government created the system, maintains it and makes it freely accessible to anyone with a GPS receiver. The global positioning system provides critical capabilities to military, civil and commercial users around the world.

- ❖ **GPS and Satellite Image:** GPS has been widely used to prepare map from Satellite images especially topographic surveys and thematic mapping.
- ❖ **Road Traffic Congestion:** A navigation device has a GPRS receiver for receiving real time information about or slow average speed on a stretch of motorway, indicating congestion. The device calculates a new itinerary to avoid the congestion, based on historically record speeds on secondary roads weighed by the current average speed in the congestion area.
- ❖ **GPS and Defense:** Corps use GPS as a modern defensive purpose like trending and rescued.
- ❖ **Accidental Purpose:** To find and rescue any crashes ship and airplanes, GPS Plays very important role.
- ❖ **Tectonics:** GPS enables direct fault motion measurement of earthquake between earthquake GPS can be used to measure crustal motion and deformation to estimate seismic strain build up for creating seismic hazard maps.
- ❖ **GPS and Terrorism:** GPS is very important to determine the location of terrorist attacks. For example, on the surgical strike, Indian intelligence agencies had using the GPS and Indian Army carried out surgical strike against terror launch pads on and along the Line of Control (LoC) on 2016.
- ❖ **GPS of Mining:** The use of RTK GPS has significantly improved several mining operations such as drilling, shoveling, vehicle tracking and surveying, RTK GPS provides centimetre-level positioning accuracy.
- ❖ **GPS and Climatology:** GPS plays very important role to prepare weather map and computerized map.
- ❖ **GPS and Tours:** Location determines what content to display, for instance, information about an approaching point of interest.
- ❖ **Navigation:** Navigators value digitally precise velocity and orientation measurements. With the help of GPS roads or paths available, traffic congestion and alternative routes, roads or paths that might be taken to get to the destination. If some roads are busy then the best route to take, The location of food, banks, hotels, fuel, airports or other places of interests, the shortest route between the two locations, the different options to drive on highway or back roads etc. are easily getting better result using GPS.
- ❖ **Disaster Relief:** GPS gives us the facility to measure the capabilities of earthquake, flood wildfires.
- ❖ **GPS-Equi Radio Sondes and Dropsondes:** GPS Measure and calculate the Atmospheric pressure, wind speed and direction up to 27 km from the earth's surface.

- ❖ **Fleet Tracking:** The use of GPS technology to identify, locate and maintain contact reports with one or more fleet vehicles in real time.
- ❖ **Robotics:** Self-navigation, autonomous robots using GPS sensors, which calculate Latitude, Longitude, Time, speed and heading.
- ❖ **Sport:** GPS also used in footballs and rugby and different sports for control and analysis of the training load.
- ❖ **Surveying:** Surveyors use absolute locations to make maps and determines property boundaries. The surveying and mapping community was one of the first to take advantage of GPS because it dramatically increased the productivity and resulted in more accurate and reliable data. Today, GPS is a vital part of surveying and mapping activities around the world.
- ❖ **Distance and Height Measurement:** GPS helps to calculate the distances and heights of different places on the earth surface.
- ❖ **Automated Vehicle:** With the help of GPS location and routes for cars and trucks to function without a human driver.
- ❖ **Agriculture:** GPS-based applications in precision farming are being used for farm planning, field mapping, soil sampling, tractor guidance, crop scouting, variable rate applications, and yield mapping. GPS allows farmers to work during low visibility field conditions such as rain, dust, fog, and darkness.
- ❖ **GPS and Fishing:** Synoptic maps of the main concentrations of fisherman villages, fishing ports and beach landing points, markets, processing, freezing and transshipment points, coastal landforms can be studied with the help of GPS.
- ❖ **GPS and Oil Leak:** GPS tracking technology is helping with the study by examining how currents are influence by winds and waves and measuring wind speed to find out how oil would spread from the ocean, onto the beach. Many instruments are being used in the study to gather as much data as possible. After data is collected, researchers plan to use 3D pictures of oil transports and hope to come up with more information about oil spills, how to mitigate their damage, and how to protect the environment.
- ❖ **Astronomy:** Both positional and clock synchronization data is used in astrometry and celestial mechanics calculations. It is also used in amateur astronomy using small telescope to professionals observations, for example, which finding extra solar planets.
- ❖ **GPS and Forestation:** GPS Technology Makes Tree Planting More efficient. Deforestation and disappearing wildlife habitats are a big problem in the modern world. Manufacturing industries use state-of-the- art technologies to produce and sell more paper and wood products, but there is growing concern over the devastation wrought by their methods of obtaining materials. The rate with which large, luscious forests are being cut down. The trees are being removed much more quickly than we can hope to replant, as trees take many years to grow to their full potential. One solution-orientated man is leading team, developing ways to replant forests as quickly and efficiently as possible, using GPS technology.
- ❖ **Topographic Mapping:** In a Ground Control Point (GCP) system, GPS tool use to prepare the topographic mapping of real world.

- ❖ **GPS and Urban Planning:** A special GPS technology has been used in urban planning and engineering survey.
- ❖ **Cartography:** Both civilian and military cartographers use GPS extensively.

## **Global Navigation Satellite System**

### **GPS (USA)**

The United States Global Positioning System (GPS) consists of up to 32 medium Earth orbit satellites in six different orbital planes with the exact number of satellites varying as older satellites are retired and replaced. Operational since 1978 and globally available since 1994, GPS is the world's most utilized satellite navigation system.

### **GLONASS (Russia)**

The formerly Soviet, and now Russian, Global'naya Navigatsionnaya Sputnikovaya Sistema, (Global Navigation Satellite System or GLONASS), is a space-based satellite navigation system that provides a civilian radio navigation-satellite service and is also used by the Russian Aerospace Defense Forces and is the Second alternative navigational system in operation. GLONASS became operational in year 1993 with 12 satellites in 2 orbits at the height of 19,130 km. At present, there are total 27 satellites in orbit and all are operational.

### **Galileo (EU)**

The European Union and European Space Agency agreed in March 2002 to introduce their own alternative to GPS, called the Galileo positioning system. Galileo became operational on 15 December 2016 (global Early Operational Capability (EOC)). At an estimated cost of €10 billion, the system of 30 MEO satellites was originally scheduled to be operational in 2010. The original year to become operational was 2014. The first experimental satellite was launched on 28 December 2005. Galileo is expected to be compatible with the modernized GPS system. The receivers will be able to combine the signals from both Galileo and GPS satellites to greatly increase the accuracy. Galileo is expected to be in full service in 2020 and at a substantially higher cost. Galileo is global navigation system available for civilian and commercial use. The fully deployed Galileo system will consist of 30 operational satellites and 6 in-orbit spares. As of now 22 out of 30 satellites are in orbit. Galileo started offering Early Operational Capability from 2016 and is expected to reach full operational capability by 2020.

### **BeiDou (China)**

BeiDou is Satellite Navigation System of China. It has total 22 Operational satellites in orbit and the full constellation is scheduled to comprise 35 satellites. BeiDou has two separate constellations, BeiDou-1 and BeiDou-2. BeiDou-1 also known as first generation was a constellation of three satellites. BeiDou-2, also known as COMPASS, is the second generation of the system. Beidou started as the now-decommissioned Beidou-1, an Asia-Pacific local network on the geostationary orbits. China has indicated their plan to complete the entire second generation Beidou Navigation Satellite System (BDS or BeiDou-2, formerly known as COMPASS), by expanding current regional (Asia-Pacific) service into global coverage by 2020. This BeiDou-3 system is proposed to consist of 30 MEO satellites and five geostationary satellites (IGSO). A 16-satellite regional version (covering Asia and Pacific area) was completed by December 2012.

Global service was completed by December 2018. It became operational in year 2000 and offered limited coverage and navigation services, mainly for users in China and neighboring regions. Beidou-1 was decommissioned at the end of 2012. It became operational in the year 2011 with a partial constellation of 10 satellites in the orbit. Next generation of it is BeiDou-3. The first BDS-3 satellite was launched in March 2015. As of January 2018, nine BDS-3 satellites have been launched. BeiDou-3 is expected to be fully functional by the end of 2020

## **Regional Navigation Satellite Systems**

### **NavIC (India)**

The Indian Regional Navigation Satellite System (IRNSS), which was later given the operational name of NavIC or Navigation with Indian Constellation (NavIC), is the regional satellite navigation system of India. Launched and operated by the Indian Space Research Organization (ISRO), IRNSS covers India and nearby regions extending up to 1,500 km.

The NavIC or Navigation with Indian Constellation is an autonomous regional satellite navigation system developed by Indian Space Research Organisation (ISRO) which would be under the total control of Indian government. The government approved the project in May 2006, with the intention of the system completed and implemented on 28 April 2016. It consists of a constellation of 7 navigational satellites. 3 of the satellites are placed in the Geostationary orbit (GEO) and the remaining 4 in the Geosynchronous orbit (GSO) to have a larger signal footprint and lower number of satellites to map the region. It is intended to provide an all-weather absolute position accuracy of better than 7.6 meters throughout India and within a region extending approximately 1,500 km around it. A goal of complete Indian control has been stated, with the space segment, ground segment and user receivers all being built in India. All 7 satellites, IRNSS-1A (1 July 2013), IRNSS-1B (4 April 2014), IRNSS-1C (16 October 2014), IRNSS-1D (28 March 2015), IRNSS-1E (20 January 2016), IRNSS-1F (10 March 2016), and IRNSS-1G (28 April 2016) of the proposed constellation were precisely launched from Satish Dhawan Space Centre.

It covers India and a region extending 1,500 km (930 mi) around it, with plans for further extension. An Extended Service Area lies between the primary service area and a rectangle area enclosed by the 30th parallel south to the 50th parallel north and the 30th meridian east to the 130th meridian east, 1,500–6,000 km beyond borders. The system at present consists of a constellation of seven satellites, with two additional satellites on ground as stand-by.

The constellation was in orbit as of 2018, and the system was operational from early 2018 after a system check. NavIC provides two levels of service, the "standard positioning service", which will be open for civilian use, and a "restricted service" (an encrypted one) for authorized users (including military). There are plans to expand NavIC system by increasing constellation size from 7 to 11.

### **QZSS (Japan)**

The Quasi-Zenith Satellite System (QZSS) is the regional satellite navigation system from Japan which is still under construction by the Satellite Positioning Research and Application Center, Japan. As per plans, the QZSS constellation

will have 7 satellites, out of which 4 are already in orbit. The Quasi-Zenith Satellite System (QZSS) is a four-satellite regional time transfer system and enhancement for GPS covering Japan and the Asia-Oceania regions. QZSS services were available on a trial basis as of January 12, 2018, and were launched in November 2018. The first satellite was launched in September 2010. An independent satellite navigation system (from GPS) with 7 satellites is planned for 2023.

### **Augmentation**

GNSS augmentation is a method of improving a navigation system's attributes, such as accuracy, reliability, and availability, through the integration of external information into the calculation process, for example, the Wide Area Augmentation System, the European Geostationary Navigation Overlay Service, the Multi-functional Satellite Augmentation System, Differential GPS, GPS-Aided GEO Augmented Navigation (GAGAN) and inertial navigation systems.

### **DORIS**

Doppler Orbitography and Radio-positioning Integrated by Satellite (DORIS) is a French precision navigation system. Unlike other GNSS systems, it is based on static emitting stations around the world, the receivers being on satellites, in order to precisely determine their orbital position. The system may be used also for mobile receivers on land with more limited usage and coverage. Used with traditional GNSS systems, it pushes the accuracy of positions to centimetric precision (and to millimetric precision for altimetric application and also allows monitoring very tiny seasonal changes of Earth rotation and deformations), in order to build a much more precise geodesic reference system Global Positioning System (United States)

### **Differential Global Positioning System (DGPS)**

A Differential Global Positioning System (DGPS) is an enhancement to the Global Positioning System (GPS) which provides improved location accuracy, in the range of operations of each system, from the 15-meter nominal GPS accuracy to about 1-3 cm in case of the best implementations.

The United States Coast Guard (USCG) and the Canadian Coast Guard (CCG) each run DGPSes in the United States and Canada on long wave radio frequencies between 285 kHz and 325 kHz near major waterways and harbors. The USCG's DGPS was named NDGPS (Nationwide DGPS) and was jointly administered by the Coast Guard and the U.S. Department of Defense's Army Corps of Engineers (USACE). It consisted of broadcast sites located throughout the inland and coastal portions of the United States including Alaska, Hawaii and Puerto Rico.[2] Other countries have their own DGPS.

A similar system which transmits corrections from orbiting satellites instead of ground-based transmitters is called a Wide-Area DGPS (WADGPS) or Satellite Based Augmentation System.

Differential Global Positioning Systems (DGPS) are GPS systems that use fixed reference locations on Earth to calculate positioning errors transmitted by the satellites in view. Since the location of these reference points is already known, they can easily calculate any positioning errors that are being transmitted



by the GPS constellation. This error information is then transmitted out to GPS devices, which use this information to calculate their accurate position.

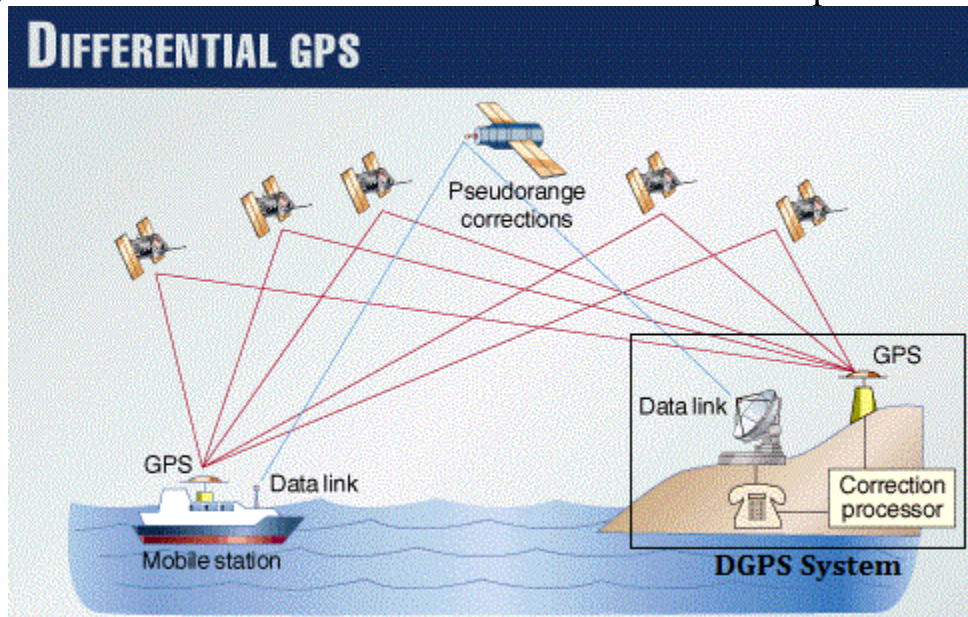

### **Difference between GPS and DGPS**

**GPS:** GPS known as Global Positioning System is a collection of number of satellites in the space sending the precise location details in the space back to Earth. Signals are obtained by the GPS instrument which uses to calculate its location, speed, and time at the location, height of the location and other info. It is very popular in the military world and was first developed by the USA military during the Cold war period. After early 1980 GPS technology is available to the public. Before the military use, 1960 was the year when GPS was first used for ship navigation by USA navy.

**DGPS:** Differential Global Positioning System (DGPS) is an enhancement to the GPS (Global Position System). GPS system based on the satellite technology can have the nominal accuracy of 15 meter whereas DPGS can bring accuracy around 10 cm. DGPS uses the fixed ground based reference stations to broadcast the difference between the coordinates from the GPS and from the fixed position from the base station. The digital correction signal is transmitted to all ground based transmitters called rovers. DGPS rely on two stations one is base station and next is rover.

- In GPS world, handheld device receive signal from the satellite for the position where as in DGPS world hand held device (rover) receives calibrated signal from the ground based transmitter.
- GPS accuracy is around 15 meters whereas DGPS is around 10 cm.
- GPS instrument can be used globally where as DGPS are meant locally may be within 100km. DGPS accuracy will start to degrade once instrument distance from ground based transmitters start to increase. Best results by the United States Department of Transportation were 0.67 m error growth within 100 km.
- GPS system is affordable compare to DGPS system which is why all smart phones have built-in GPS system.
- In GPS satellite transmit signal in frequency ranging from 1.1 to 1.5 GHz. In DGPS frequency varies by agencies, here is the list of frequency used by different agency.

- GPS accuracy is highly depending upon the number of satellites used for the calculation, for example there will be better accuracy on open space compare to the forested area. DGPS accuracy is not affected by these variables. It might be affected by the distance between transmitters and the instrument (rover).
- Most of the time coordinate system used in GPS will be WGS84 in Longitude and Latitude format where as DGPS might have local coordinate system.
- GPS instruments cover the wide range and can be used globally while DGPS instruments cover a short range up to 100 km, but this range could change according to the frequency band.
- GPS system is less expensive as compared to DGPS system.
- The factors that affect the accuracy of the GPS system are selective availability, satellite timing, atmospheric conditions, ionosphere, troposphere and multipath. In contrast, the DGPS system is affected by the distance between the transmitter and rover, ionosphere, troposphere and multipath but at less extent.

Basis for Comparison	GPS	DGPS
Number of receivers used	Only one, i.e., Stand-alone GPS receiver	Two, Rover and stationary receivers
Accuracy	15-10 m	10 cm
Range of the instruments	Global	Local (within 100 km)
Cost	Affordable as compared to DGPS	Expensive
Frequency range	1.1 - 1.5 GHz	Varies according to agency
Factors affecting the Accuracy	Selective availability, satellite timing, atmospheric conditions, ionosphere, troposphere and multipath.	Distance between the transmitter and rover, ionosphere, troposphere and multipath.
Time coordinate system used	WGS84	Local coordinate system
Range	GPS's instruments range is global.	While DGPS's instruments range is local.

### Applications of DGPS

- **Air Navigation:** One of its more popular applications is in air navigation. By using it a pilot can receive constant information about where the plane is in 3 dimensions.
- **Farming:** It is also becoming a hot topic in precision farming. Farmers can use DGPS to map out their crops, map crop yields, and control chemical applications and seeding.
- **Hydrographic Survey:** It is also proving to be useful in ground and hydrographic surveying.

- **Weather forecast:** Another application is in weather forecasting, where atmospheric information can be gained from its effects on the satellite signals.
- **Coastal Monitoring:** There has also been at least one experiment where it was used for beach morphology and monitoring.
- **Transport:** DGPS can also be used for train control for such things as avoiding collisions and routing.
- **City Administrative:** There is even been research into using it to help the visually impaired in getting around in cities.
- **Car Navigation:** There is also at least one project that is working on using DGPS for car navigation.
- **Sports field:** In the sports world it is finding a place in balloon and boat racing. It will eventually become an integral part of much of our technology.

### **DGPS: - Differential Global Positioning System**

A **Differential Global Positioning System (DGPS)** is an enhancement to the Global Positioning System (GPS) which provides improved location accuracy, in the range of operations of each system, from the 15-metre (49 ft) nominal GPS accuracy to about 1–3 centimetres (0.39–1.18 in) in case of the best implementations.

- ❖ DGPS refers to using a combination of receivers and satellites to reduce/eliminate common receiver based and satellite based errors reduce orbit errors reduce ionospheric and tropospheric errors reduce effects of SA eliminate satellite and receiver clock errors
- ❖ improve accuracy significantly 100's of metres to metres to centimetres to millimetres

1. DGPS uses one or several (network) fixed ground based reference stations (in known locations).
2. The base station compares its own known location, to that computed from a GPS receiver.
3. Any difference is then broadcast as a correction to the user.

Correction signals can be broadcast either from ground stations, or via additional satellites. These services are privately owned and usually require a user subscription.

Examples:

- ❖ Satellite Based Augmentation System (SBAS),
- ❖ Wide Area Augmentation System (WAAS),
- ❖ Local Area Augmentation System (LAAS),
- ❖ European Geostationary Navigation Overlay Service (EGNOS),
- ❖ Omni STAR
- ❖ Coast guard beacon service.

### **Need of Differential GPS:**

By using DGPS we can improve our positional accuracy from around 1.5m with standard GPS to around 40cm with DGPS, without the need for post processing.

In the case of the road survey van (top right), users can measure the amount of road wear and judge whether the road should be resurfaced just by driving over it.

Just one day's driving can replace a month's manual work using traditional methods.

There are many other applications like this. The labour saving is immense but at the same time, previously impossible tasks are made possible such as the prediction of earthquakes before they occur.

### **Real Time Kinematic (RTK)**

Real Time Kinematic is an advanced form of DGPS which uses the satellites carrier wave to compare 2 observations from different receivers within the system, to fine tune the satellite and receiver clock errors, thus improving positional accuracy.

The GPS signal is made up of 3 distinct components:

- Carrier wave
- GPS Code
- Navigation message

Typical GPS receivers will use the GPS navigation message to calculate its position. RTK uses the carrier wave of the GPS signal, which is 19.02cm long. By counting the number of cycles (and phase of the carrier), the travel time and distance can be measured more accurately.

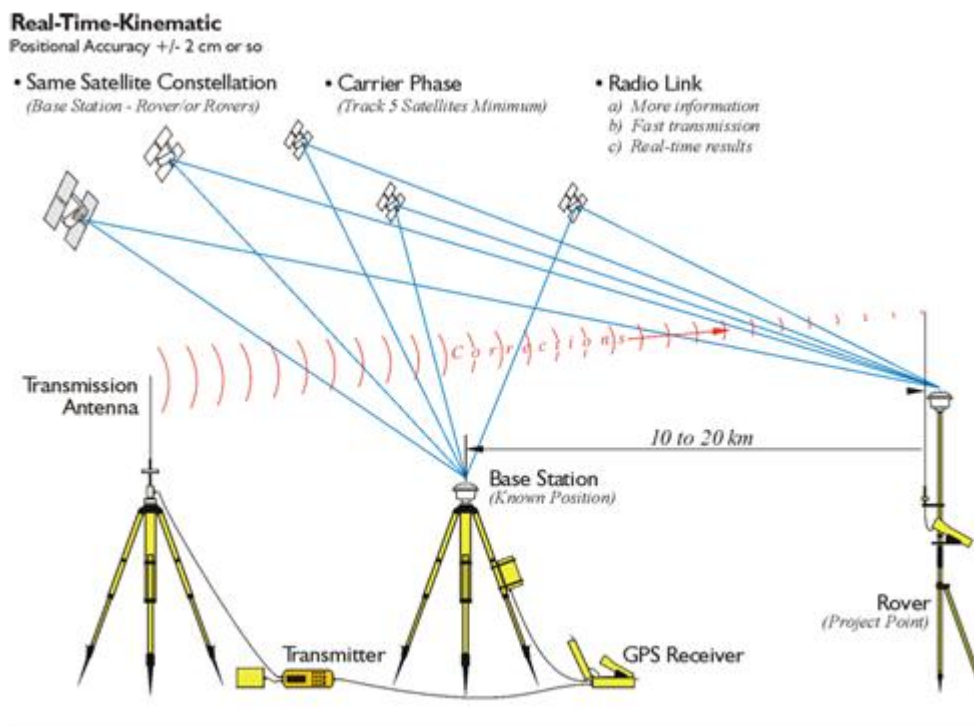

**Fig.—RTK GPS basic concept**

### **Base Station Setup**

A base station consists of a receiver that is placed at a known (and fixed) position. The receiver tracks the same satellites that are being tracked by the rover receiver, at the same time that the rover is tracking them. Errors in the GPS system are monitored at the fixed (and known) base station, and a series of position corrections are computed. The messages are sent through a radio link to the rover receiver, where they are used to correct the real time positions of the rover.

## **Base station components**

The base station has the following components:

- ❖ GPS receiver
- ❖ GPS antenna
- ❖ Base station radio
- ❖ Power supply

## **GPS receiver and GPS antenna**

The base station GPS receiver can be one of following types:

- A Smart GPS antenna, such as the SPS882, that incorporates a GPS receiver, GPS antenna, power supply, and radio into a single compact unit. A Smart GPS antenna can be rapidly set up on a tripod, fixed height tripod, or T-Bar anywhere that is convenient on the jobsite.
- A Modular receiver, such as the SPS852, that incorporates a GPS receiver, power supply, and radio in a single unit. The GPS antenna (and, optionally, the base station radio antenna) is separate from the receiver. Because the GPS antenna is separate, you can use the following optimized components:
  - ❖ a geodetic antenna with large ground plane, to eliminate multipath (the major source of GPS errors) at the base station
  - ❖ a high-gain or directional radio antenna, to increase broadcast range and to provide maximum coverage

You can also place an SPS Modular receiver in an easily accessible and secure location, safe from theft and the weather, while the antennas are placed high on a tower or building, clear of obstructions and able to deliver maximum performance.

You can use either type of receiver in a permanent, semi-permanent, or daily quick setup configuration. If semi-permanent or permanent operation is required, however, the modular receiver delivers significant advantages.

## **Base station setup guidelines**

For good performance, observe the following base station setup guidelines:

- Place the GPS receiver in a location on the jobsite where equal range in all directions provides full coverage of the site. This is more important on larger jobsites, where the broadcast range of the base station radio may limit the operations of the GPS system.
- Place the GPS antenna in a location that has a clear line of sight to the sky in all directions. Do not place the GPS antenna near vertical obstructions such as buildings, deep cuttings, site vehicles, towers, or tree canopy.
- Place the GPS and radio antennas as high as practical. This minimizes multipath from the surrounding area, and enables the radio to broadcast to the maximum distance.

*Note – The GPS antenna must have a clear line of sight to the sky at all times during operation.*

- Choose the most appropriate radio antenna for the size and footprint of the site. The higher the gain on the antenna, the longer the range. If there is more focus on the transmission signal, there is a reduced coverage area. A 3 db or 5 db gain antenna provides a mix of good range and reasonable directional coverage.

- Make sure that the GPS receiver does not lose power. The GPS receiver has an integrated battery that must be charged. To operate continuously for more than a day without loss of power at the base station, provide external power. Sources of external power include:
  - ✓ AC power
  - ✓ 12 V car or truck battery
  - ✓ Trimble custom external battery pack
  - ✓ Generator power
  - ✓ Solar panel

When you use an external power supply, the integrated battery provides a backup power supply, enabling you to maintain continuous operation through a mains power failure.

When the GPS receiver is connected to a power source that can support the power drain, the integrated battery is continuously charged from the connected power source. This helps to ensure that the battery stays charged (SPS Modular only).

- Do not locate a GPS receiver, GPS antenna, or radio antenna within 400 meters (about 1,300 feet) of:
  - a powerful radar, television, or cellular communications tower
  - another transmitter
  - another GPS antenna

Cell phone towers can interfere with the base station radio broadcast and can stop corrections from reaching the rover receiver. High-power signals from a nearby radio or radar transmitter can overwhelm the receiver circuits. This does not harm the receiver, but can prevent the receiver electronics from functioning correctly.

Low-power transmitters, such as those in cell phones and two-way radios, do not interfere with receiver operations.

- Do not set up the base station directly beneath or close to overhead power lines or electrical generation facilities. The electromagnetic fields associated with these utilities can interfere with GPS receiver operation. Other sources of electromagnetic interference include:
  - ✓ Gasoline engines (spark plugs)
  - ✓ Televisions and computer monitors
  - ✓ Alternators and generators
  - ✓ Electric motors
  - ✓ Equipment with DC-to-AC converters
  - ✓ Fluorescent lights
  - ✓ Switching power supplies

Place the GPS receivers in a protected and secure location. If the base station is in the center of a jobsite where heavy machinery is operating, place flags around the base station to warn operators of its existence.

If you place the SPS Modular receiver in a lock box on the jobsite to protect the receiver from theft or from the weather, shield the lock box from direct sunlight and provide ventilation for the receiver through an inlet and extractor fan. A receiver that has a broadcast radio generates

significant heat. Do not allow the temperature in the box to exceed 50 °C (122 °F).

If working in a cold climate, you may need to provide heat to the receiver. Do not operate the receiver below –40 °C (–40 °F).

### **Rover GPS Set up**

The second part of the RTK GPS system is the rover receiver. The rover receiver is mounted on a pole, vehicle, marine vessel, or in a backpack, and is moved between the points that require measurement or stakeout. The rover receiver is connected to a base station or to a source of RTK corrections such as a VRS system. The connection is provided by:

- an integrated radio
- a cellular modem in the controller
- an external cellular phone that is connected to the receiver either by Bluetooth wireless technology or by means of a cable

The correction stream for some other positioning solutions, such as SBAS, Beacon, and the OmniSTAR service, is detected by the GPS or combined GPS/Beacon antenna itself. No integrated radio or base station is required.

### **Rover receiver components**

The rover receiver has the following components:

- GPS receiver
- One GPS antenna
- Optional integrated radio receiver and antenna for RTK operations
- Optional items for the different mounting options

In most rover applications, the receiver operates entirely from its own integrated battery unit. On a vehicle or on a marine vessel, however, an external power supply can be used. Use an external power supply if one is provided. The internal battery then acts as a uninterruptible power supply, covering any external power failures.

Choose a rover receiver according to the needs of the job:

- A Smart GPS antenna, such as the SPS882, incorporates the GPS receiver, GPS antenna, power supply, and receive radio into a single compact unit. A Smart GPS antenna can be rapidly set up on a pole, vehicle, or backpack. This makes it easy to carry when you are measuring around the jobsite.
- A Modular receiver, such as the SPS351, incorporates the GPS receiver, receive radio, and power supply into a single unit. The GPS antenna and, optionally, the receive radio antenna, is separate from the receiver. When you use an SPS Modular receiver as a rover, you can use optimized components placed in the best locations for your application. For example:
  - ✓ A small, lightweight rover antenna can be mounted on a pole or backpack; placed in a high, inaccessible location on a marine vessel mast or cabin; or placed on a site vehicle roof or truck bed.
  - ✓ A rubber duck radio antenna, or an external radio antenna, can be mounted on a vehicle or vessel roof to provide maximum coverage.

An SPS Modular receiver can be placed in a location that is both easily accessible and safe from theft and the weather. The antennas can be placed high on a vehicle or vessel roof, clear of obstructions and able to deliver maximum performance.

### **Rover receiver setup guidelines**

For good rover operation, observe the following setup guidelines:

- Place the GPS antenna in a location that has a clear line of sight to the sky in all directions. Do not place the antenna near vertical obstructions such as buildings, deep cuttings, site vehicles, towers, or tree canopy. GPS rovers and the base station receive the same satellite signals from the same satellites. The system needs five common satellites to provide RTK positioning. Place the two GPS antennas at least 2 meters (6.5 feet) apart and at approximately the same height.
- Place the GPS and radio antennas as high as possible to minimize multipath from the surrounding area. The receiver must have a clear line of sight to the sky at all times during operation.
- GPS satellites are constantly moving. Because you cannot measure at a specific location now does not mean that you will not be able to measure there later, when satellite coverage at the location improves. Use GPS planning software to identify the daily best and worst satellite coverage times for your location and then choose measurement times that coincide with optimal GPS performance. This is especially important when operating in the worst GPS locations. You can download the Trimble Planning software from the Trimble website ([www.trimble.com/planningsoftware\\_ts.asp](http://www.trimble.com/planningsoftware_ts.asp)).
- The SPS Modular can track the GPS L2C modernization signal. Additionally, they can optionally track the GPS L5 modernization signal and can also track the GLONASS satellite constellation (for more information, see [SPS851 signal tracking](#)). The signals help you to get positions at the worst times of the day and in the worst GPS locations, but does not guarantee that you will.
- To get a fixed position solution with centimeter accuracy, initialize the Precision RTK rover receiver. For initialization to take place, the receiver must track at least five satellites that the base station is also tracking. In a dual-satellite constellation operation, for example, GPS and GLONASS, the receiver must track at least six satellites.
- To maintain a fixed position solution, the rover must continuously track at least four satellites that the base station is also tracking. The radio link between the base and rover receivers must also be maintained.
- Loss of the satellite signals or loss of the radio link will result in a loss of centimeter position accuracy.
- From Fixed, the receiver changes to Float or Autonomous mode:
  - In Float mode, the rover has connection to the base station through a radio, but has not yet initialized.
  - In Autonomous mode, the rover has lost radio contact with the base station receiver, and is working by itself with the available GPS signals.



On a vehicle or marine vessel, place the GPS antenna in a location as free from shock and vibration as possible. For the SPS Modular receivers, a single magnetic mount is normally sufficient to hold the antenna in a suitable location, whereas for the larger smart antenna, a triple magnetic mount is normally recommended. Good alternatives include a 5/8" thread bolt in a suitable location on the roof or bull bars, or a door-mounted pole bracket.

To mount an SPS Modular receiver on a pole, use two pole mounting brackets and a second tripod clip. See the following figure.

- **(SPS Modular)** Make sure that the rover receiver does not lose power. An SPS Modular receiver (except for the SPS351 and SPSx61) is typically powered by its internal battery. You cannot change the battery, but the charge typically lasts for longer than a working day. If you do not use the rover receiver very often, ensure that it is charged at least every three months. For vehicle operation or marine vessel operation, Trimble recommends that you use an external power source so that the internal battery can be saved for times when the receiver is being used off the vehicle or vessel.
- **(SPS882)** Make sure that the rover receiver does not lose power. The [batteries in the SPS882](#) can be changed when flat. If you do not use the rover receiver very often, ensure that it is charged at least every three months. For vehicle operation or marine vessel operation, Trimble recommends that you use an external power source so that the internal battery can be saved for times when the receiver is being used off the vehicle or vessel.
- Do not locate the receiver or antenna within 400 meters (about 1,300 ft) of powerful radar, television, cellular communications tower, or other transmitters or GPS antennas. Low-power transmitters, such as those in cellular phones and two-way radios, normally do not interfere with receiver operations. Cellular communication towers can interfere with the radio and can interfere with GPS signals entering the receiver. This does not harm the receiver, but it can prevent the receiver electronics from functioning correctly.
- Do not use the rover receiver directly beneath or close to overhead power lines or electrical generation facilities. The electromagnetic fields associated with these utilities can interfere with GPS receiver operation. Other sources of electromagnetic interference include:
  - gasoline engines (spark plugs)
  - televisions and computer monitors
  - alternators and generators
  - electric motors
  - equipment with DC-to-AC converters
  - fluorescent lights
  - switching power supplies

Trimble recommends that, wherever possible, all GPS receiver equipment is protected from rain or water. Although, the receivers are designed to withstand all wet weather conditions, keeping the receivers dry prolongs

the life of the equipment and reduces the effects of corrosion on ports and connectors. If the equipment gets wet, use a clean dry cloth to dry the equipment and then leave the equipment open to the air to dry. Do not lock wet equipment in a transport case for prolonged periods. Wherever possible, avoid exposing the GPS receiver to corrosive liquids and salt water.

If you are using the rover receiver in open spaces, Trimble recommends that you stop work during electrical storms where the risk of lightning strike is high.

Where cables are involved, Trimble recommends that you use cable ties to secure the cables to the rod or other equipment to avoid inadvertent snagging while moving about the jobsite. Be careful not to kink, twist, or unnecessarily extend cables, and avoid trapping them in vehicle doors or windows. Damage to cables can reduce the performance of GPS equipment.

### **Download , Post-Process and Export GPS data**

After the field data collection, you will need to transfer data from the GPS to a PC and perform post-processing. All collected GPS data needs some form of post-processing whether it is differential correction and/or editing. After transferring, view your data on the PC for verification. While your data file is onscreen, you can identify any unwanted positions and/or features as well as attribute information and perform preliminary editing. Depending on your GPS unit and data collection software, this step may or may not include converting the data to a GIS format at the time of downloaded. Either way, it is important to have clear procedures for post-field data management and verification.

Steps to take when returning to the office.

1. Transfer GPS files which may include GPS Data Files, base files and almanacs into your project's file structure. See suggested project and data file structures in the [Project Management & Data Dictionary Design](#) Step.
2. Run differential correction, if your GPS unit and PC setup has the capability.  
Data collected with real-time differentially correction should not skip this step if their GPS setup has the capability. Depending on your equipment and real-time acquisition of either satellite or broad-band signals, you still may require post-processing differential to correct positions not corrected in real-time.
3. Combine data files. At the end of a long GPS field day(s) you may have generated multiple files. Combining files allows you to edit multiple files together.
4. Verify data onscreen. Display or verification of the data ensures the data "looks right" and is not a dataset left on a datalogger from someone else. Data display, depending on the software used, allows for viewing of the data in relationship with other background files, and has query functions to identify feature attributes.
5. Perform preliminary editing.

Be sure to work on a copy of the raw data!!! Depending on your GPS viewing software's capabilities there may be tools available to perform preliminary editing and assess quality. Editing tools are used to remove unwanted mistakes during collection, positions collected during un-cooperative satellite times and intersecting vertices between area or line features. Mistakes or errors not removed in this step, can be edited during the [Finalizing GIS Data](#) step after the GPS data is exported to a GIS format. GIS software packages usually provide more editing capability and flexibility.

- Points require almost no editing, but may require close inspection. Does the point line up with other features in the GIS? If misplaced, consult the notes for the feature and assess in-field quality issues that may have arisen (ie. poor PDOP, EPE, or operator error). Many times you may forget to close a point feature before walking away, thus creating a point hundreds of feet away from the intended spot.
  - Lines and Polygons may require extensive editing. Due to errors in GPS signals, or obstructions like canopy or large buildings, there may be cases where the road feature appears like a zigzag or the polygon feature collapses upon itself. Delete positions that deviate from the trend of a straight line, remove positions that cross over each other at intersections or delete a series of positions that were collected if you stood too long at a beginning of a trial or failed to pause during collection. ([See a graphic of this!!](#)). Graphic credit: GPS Field School Training Manual - Cultural Resources GIS, May 1998
  - Attribute validation is also an editing function that can be used after the field to enforce attribute structure and ensure attribute values are filled in appropriately. Trimble users can edit attributes with Pathfinder Office Software if data was collected using a predefined data dictionary file (\*.ddf). Autonomous Garmin users must utilize GIS software to enforce attribute structure after the data has been exported to a GIS dataset format.
6. Clear out the GPS unit for the next job or person. Do not leave data files on the GPS unit if they have been properly downloaded and verified.
  7. Lastly, charge or refresh your batteries. Use this time when returning from the field to charge any internal or external batteries for your next trip. Refresh the supply of external batteries if charging is not an option.

### **Sequence to download GPS data from flashcards**

#### **Sequence to Post-Process GPS data**

When you're collecting GPS data that's going to be post-processed, you need a GPS receiver (and software) that's going to be able to record satellite observation data. Otherwise, data is collected as one normally would in the field, whether it's utility poles, manhole covers, road centerlines or polygons of any sort.

The accuracy of the GPS data while you're in the field is autonomous GPS, so it could be several meters or even ten meters or more. You can't use this type of method for navigating to a point with any sort of accuracy better than a few meters.

After you're finished collecting your GPS data for the day, you go back to the office and download your data to your computer. Post-processing requires special

software. That software will allow you to search the Internet for the closest GPS base station(s) to use as a source of GPS corrections. In previous years, it was a laborious task to search for GPS base-station data that was recorded the same time as you were in the field (remember UTC vs. local time?). That's not the case any longer as advanced post-processing software has made this a more automated process. The software will search for the closest base station and automatically select the appropriate files to download.

It takes specialized software and training to utilize post-processing effectively.

When you're collecting GPS data that's going to be post-processed, you need a GPS receiver (and software) that's going to be able to record satellite observation data. Otherwise, data is collected as one normally would in the field, whether it's utility poles, manhole covers, road centerlines or polygons of any sort.

The accuracy of the GPS data while you're in the field is autonomous GPS, so it could be several meters or even ten meters or more. You can't use this type of method for navigating to a point with any sort of accuracy better than a few meters.

After you're finished collecting your GPS data for the day, you go back to the office and download your data to your computer. Post-processing requires special software. That software will allow you to search the Internet for the closest GPS base station(s) to use as a source of GPS corrections. In previous years, it was a laborious task to search for GPS base-station data that was recorded the same time as you were in the field (remember UTC vs. local time?). That's not the case any longer as advanced post-processing software has made this a more automated process. The software will search for the closest base station and automatically select the appropriate files to download.

It takes specialized software and training to utilize post-processing effectively.

### **ETS:-Electronic Total station**

- The Total station is designed for measuring of slant distances, horizontal and vertical angles and elevations in topographic and geodetic works, tachometric surveys, as well as for solution of application geodetic tasks. The measurement results can be recorded into the internal memory and transferred to a personal computer interface.
- The basic properties are unsurpassed range, speed and accuracy of measurements. Total stations are developed in view of the maximal convenience of work of the user. High-efficiency electronic tachometers are intended for the decision. It has the broad audience for sole of industrial problems.
- Angles and distances are measured from the total station to points under survey, and the coordinates (X, Y, and Z or northing, easting and elevation) of surveyed points relative to the total station position are calculated using trigonometry and triangulation.
- Data can be downloaded from the total station to a computer and application software used to compute results and generate a map of the surveyed area.
- A total station is an electronic/optical instrument used in modern surveying. It is also used by archaeologists to record excavations as well as

by police, crime scene investigators, private accident Reconstructionists and insurance companies to take measurements of scenes. The total station is an electronic theodolite (transit) integrated with an electronic distance meter (EDM), plus internal data storage and/or external data collector.

- The purpose of any survey is to prepare maps, control points formed a basic requirement for the preparation of these maps.
- There are several numbers of methods like traverse, triangulation etc., to provide these control points.
- Whatever the method the provision of control points, includes the measurement of two entities( Distance and Angle).
- Again, distance can be measured by using various instruments like chain, tape.
  - ❖ Linear Tap.
  - ❖ Gunter's chain (20m and 30m).
  - ❖ Steel band(20m and 30m).
  - ❖ Inver tap.
  - ❖ Hunter Short Base (80m).
  - ❖ Electronic Distance Measurement Instruments, Total station and GPS.
  - ❖ Angle can be measured by using a THEODOLITE.
- Once distance and angular measurement is over computation is performed to provide the control points. A combination of all the three results in a powerful instrument called TOTAL STATION.Hence, the TOTAL STATION is an instrument which consists of the following:
  - (a) Distance measuring instrument (EDM).
  - (b) An angle measuring instrument (Theodolite).
  - (c) A simple microprocessor.



**Fig. Total Station**

A total station consists of a theodolite with a built-in distance meter (distancer), and so it can measure angles and distances at the same time. Today's electronic total stations all have an opto-electronic distance meter (EDM) and electronic angle scanning. The coded scales of the horizontal and vertical circles are scanned electronically, and then the angles and distances are displayed digitally. The horizontal distance, the height difference and the coordinates are calculated automatically and all measurements and additional information can be recorded.

Total stations are used wherever the positions and heights of points, or merely their positions, need to be determined.

### **Distance Measurement**

When a distance is measured with a total station a electromagnetic pulse is used for measurement – this is propagated through the atmosphere from instrument to a prismatic reflector or target and back during measurement. Distances are obtained by measuring the time taken for a laser radiation to travel from the instrument to a prism (or target) and back. The pulses are derived from an infrared or visible laser diode and they are transmitted through the telescope towards the remote end of the distance being measured, where they are reflected from a reflector and return to the instrument. Since the velocity  $v$  of the pulses can be accurately determined, the distance  $D$  can be obtained using  $2D = vt$ , where  $t$  is the time taken for a single pulse to travel from instrument-target-instrument. This is also known as the timed-pulse or time of flight measurement technique, in which the transit time  $t$  is measured using electronic signal processing technique.

When measuring distances to a reflector telescope uses a wide visible red laser beam, which emerges coaxially from the telescope's objective.

When reflector less measurements are made telescope uses a narrow visible red laser beam which emerges coaxially from the telescope's objective

### **Angle Measurement**

An angle represents the difference between two directions.

The horizontal angle  $\alpha$  between the two directions leading to the points P1 and P2 is independent of the height difference between those points, provided that the telescope always moves in a strictly vertical plane when tilted, whatever its horizontal orientation. This stipulation is met only under ideal conditions.

The vertical angle (also termed the zenith angle) is the difference between a prescribed direction (namely the direction of the zenith) and the direction to the point under consideration.

The vertical angle is therefore correct only if the zero reading of the vertical circle lies exactly in the zenith direction, and also this stipulation is met only under ideal conditions.

Deviations from the ideal case are caused by axial errors in the instrument and by inadequate levelling-up (refer to section: "Instrument errors").

Z1 = zenith angle to P1

Z2 = zenith angle to P2

$\alpha$  = Horizontal angle between the two directions leading to the points P1 and P2, i.e. the angle between two vertical planes formed by dropping perpendiculars from P1 and P2 respectively

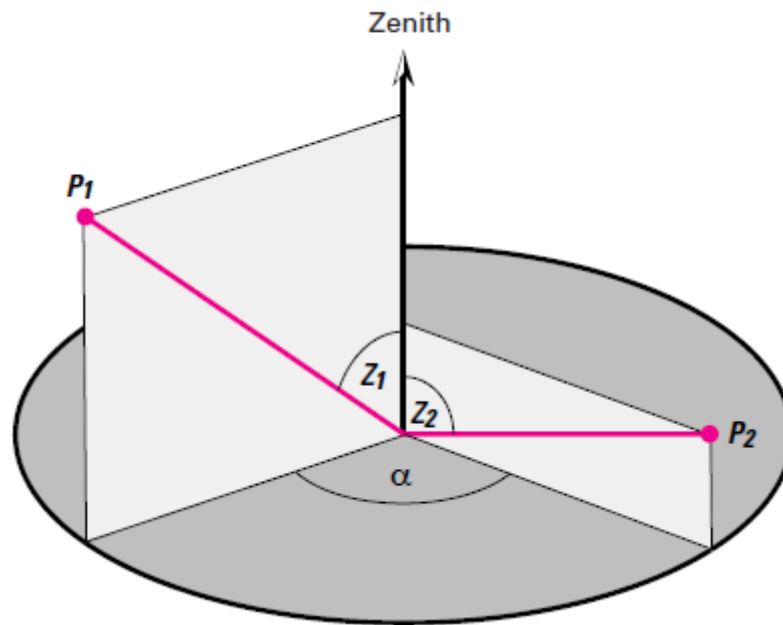

### Levelling

- Adjust the leveling foot screws to center the survey point in the optical plummet reticle
- Center the bubble in the circular level by adjusting the tripod legs

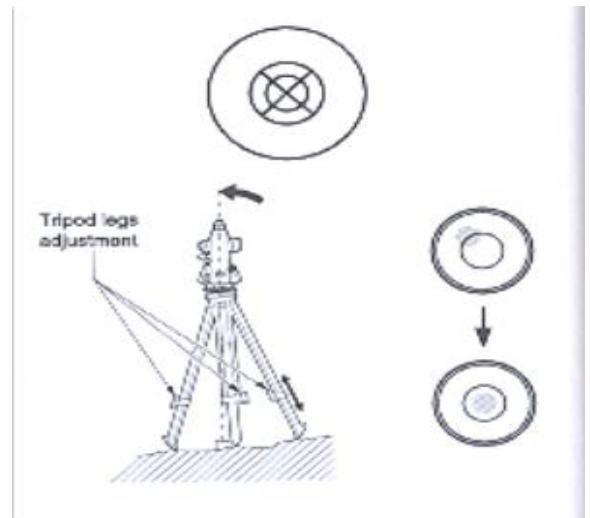

- Loosen the horizontal clamp and turn instrument until plate level is parallel to 2 of the leveling foot screws
- Center the bubble using the leveling screws- the bubble moves toward the screw that is turned clockwise
- Rotate the instrument 90 degrees and level using the 3rd leveling screw

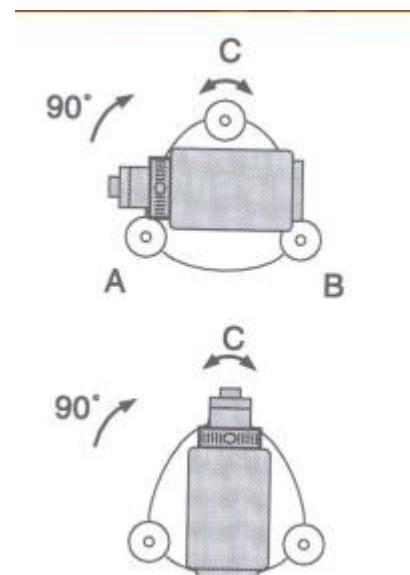

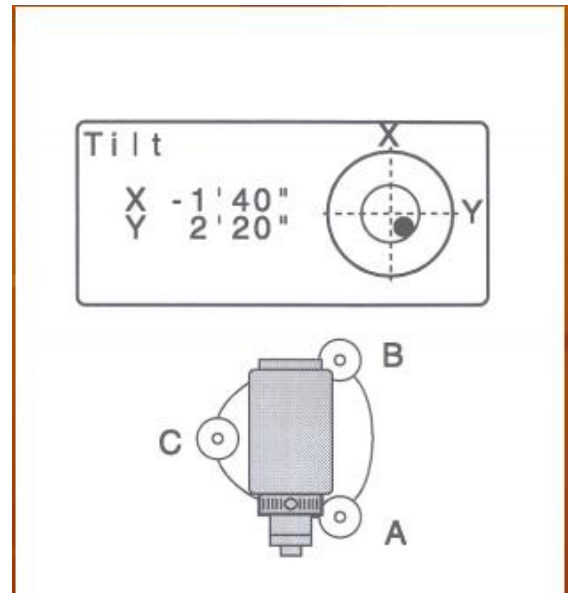
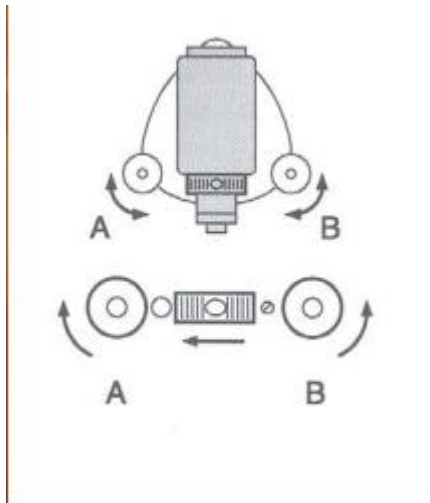

- Observe the survey point in the optical plummet and center the point by loosening the centering screw and sliding the entire instrument
- After re-tightening the centering screw check to make sure the plate level bubble is level in several directions
- Turn on the instrument by pressing and holding the “on” button (you should hear an audible beep)
- The opening screen will be the “MEAS” screen. Select the [Tilt] function Adjust the foot level screws to exactly center the electronic “bubble”
- Rotate the instrument 90 degrees and repeat

### Determining Position

Before starting the survey with Total Station you have to find out the Position of staving station. These positions can either be predetermined from a previous survey, or determined using a differential GPS such as OmniStar.

Locate the positions of the two points P1 and P2 with OmniStar. In this example P1 will be the base station and P2 is the remote station. OmniStar provides Data in Lat/Long GDA94, so, as the Total Station operates in metres, not degrees (in other words UTM) you will have to convert the Lat/Longs to UTM using GeoCalc.

### Reference Networks

In order to evaluate the accuracy and precision of the surveyed data, primary it has been established a network of control points which can serve as a reference for Total Station. The reference network was established fourteen control points using a total station. To determine the network with high precision, measurements have been taken in two faces with two rounds. Four points of the reference network were also measured with static GPS in order to transform the datum from the local coordinate system to the required coordinate system, SWEREF 99. Thus, this network served as a reference value. The precision of the Total Station evaluated depending on this reference value.



The field measurements were taken using three different surveying instruments: - Global Positioning System (GPS) and total station (TS). To eliminate instrumental errors such as line of sight errors, tilting axis errors and vertical index errors (see Table), two face measurements were taken. Since the coordinates determined with total station are provided in local coordinate system, static GPS measurement was needed to transform the datum to SWEREF 99. Then, precision of the network has been obtained from network adjustment and verified for if there have been gross errors were occurred.

### Errors and Accuracy

Total station measurements are affected by changes in temperature, pressure and relative humidity, but it can be corrected for atmospheric effects by inputting changes in temperature, pressure and relative humidity. Shock and stress result in deviations of the correct measurement as a result decreases the measurement accuracy. Beam interruptions, severe heat shimmer and moving objects within the beam path can also result in deviations of the specified accuracy by the manufacture as specified. It is therefore important to check and adjust the instrument before measurement.

The accuracy with which the position of a prism can be determined with Automatic Target Recognition (ATR) depends on several factors such as internal ATR accuracy, instrument angle accuracy, prism type, selected EDM measuring program and the external measuring conditions. The ATR has a basic standard deviation level of  $\pm 1$  mm but above a certain distance, the instrument angle accuracy predominates and takes over the standard deviation of the ATR manual. Leica 1201 total station instruments have standard deviation of 0.3 mgon in both angles which affect the quality of measurement (Leica 1200+ TPS manual). Typical Leica 1200+ instrument accuracy (horizontal and vertical angles) stated by the manufacturer are given in the Table .

**Table : Angle measurement accuracy**

Type of instrumnt	Standared deviation (Horizontal and Vertical angles)	
	[arcsecond]	[mgon]
1201+	1	0.3
1202+	2	0.6
1203+	3	1.0
1205+	5	1.5

Using different prisms other than the intended prism may cause also deviations and therefore it is important to use a Leica circular prism as the intended target.

### Measurement Errors

Some errors, those associated with the instrument, can be eliminated or at least reduced with two face measurement. Table shows instrumental errors which influence both horizontal and vertical angles, and their adjustment method.

**Table : Angle errors and their adjustment.**

Instrument error	Affects Hz angle	Affects V angle	Eliminated with two face measurement	Corrected with instrument calibration
Line of sight error	Yes	No	Yes	Yes
Tilting axis error	Yes	Yes	Yes	Yes
Compensator errors	Yes	Yes	No	Yes
V-index error	Yes	Yes	Yes	Yes

**Collimation axis error (line of sight error)** affects the horizontal angle to be deviated and resulting in poor accuracy measurement. This axial error is caused when the line of sight (see Fig.) is not perpendicular to the tilting axis. It affects all horizontal circle readings and increases with steep sightings, but this effect can be corrected by taking average of two face measurement in two rounds. For single face measurements, an on-board calibration function is used to determine collimation errors, the deviation between the actual line of sight and a line perpendicular to the tilting axis.

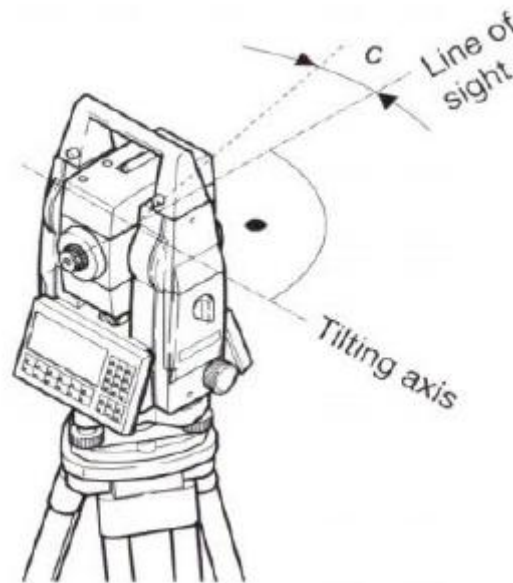

**Fig.:** Collimation errors

**Compensator index error:** errors caused by not leveling a theodolite or total station carefully and then cannot be eliminated by taking two face measurements. If the total station is fitted with a compensator it will measure residual tilts of the instrument and will apply corrections to the horizontal and vertical angles for these.

**Vertical Collimation (vertical index) error:** a vertical collimation error occurs if the 0o to 180o line in the vertical circle does not coincide with the vertical axis. This zero point error is present in all vertical circle readings and like the horizontal collimation error it is eliminated by taking two face measurements.

## **BASICS OF GIS AND MAP PREPARATION USING GIS**

The concept of geographic information systems (GIS) is not new. It was first applied conceptually when maps on the same topic made on different dates were viewed together to identify changes. Similarly, when maps showing different kinds of information for the same area were overlaid to determine relationships, the concept of GIS was actually in use. What is new and progressing rapidly is advancing computer technology, which allows the low-cost examination of large areas frequently, and with an increasing amount of data. Digitization, manipulation of information, interpretation, and map reproduction are all steps in generating a GIS that now can be achieved rapidly, almost in real time.

The concept of a GIS is basically analogous to a very large panel made up of similarly shaped open boxes, with each box representing a specified area on the earth's surface. As each element of information about a particular attribute (soil, rainfall, population) that applies to the area is identified, it can be placed into the corresponding box. Since there is theoretically no limit to the amount of information that can be entered into each box, very large volumes of data can be compiled in an orderly manner. After assigning relatively few attributes to the box system, it becomes obvious that a collection of mapped information has been generated and can be overlaid to reveal spatial relationships between the different attributes, i.e., hazardous events, natural resources, and socio-economic phenomena (see Figure ).

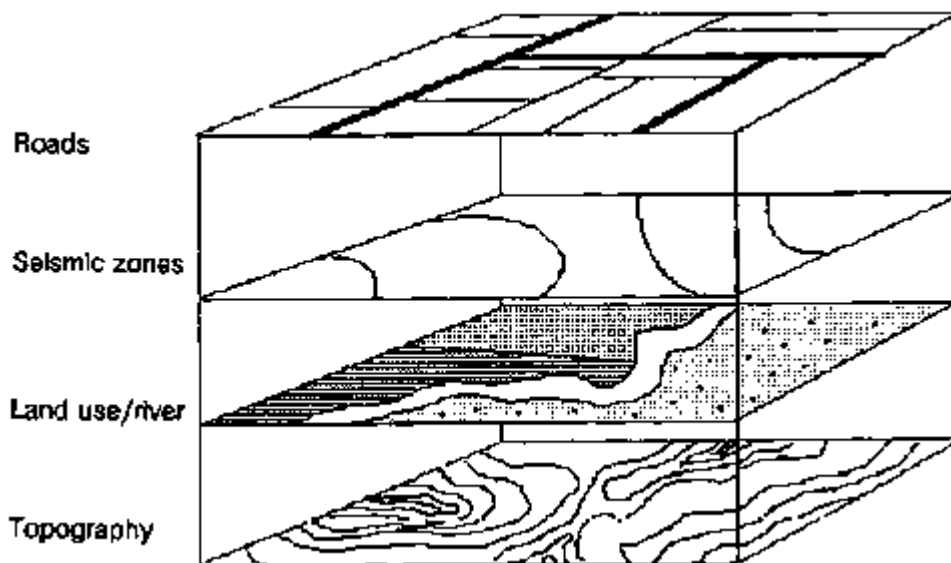

**Fig.**Overlay characteristics of a GIS

There are many kinds of GIS, some more suitable for integrated development planning studies and natural hazard management than others. At the most elementary level, there are simple manual overlay techniques, such as the one proposed by McHarg in *Design with Nature*, which have proven to be very valuable tools. However, the information needed for hazard management and development planning can become so overwhelming that it is almost impossible to cope with it manually. At the other extreme are highly sophisticated computerized systems that can analyze baseline scientific data such as satellite imagery and can produce, by using plotters, large-scale maps of excellent

cartographic quality. Such systems are very expensive, difficult to operate, and may exceed the needs of many planning offices.

Among computerized GIS, PC-based GIS are most affordable and relatively simple to operate, capable of generating maps of varying scales and tabular information suitable for repeated analysis, project design, and decision-making. Even though PC-based GIS may not produce maps of cartographic quality or sufficient detail for engineering design, they are most viable for planning teams analyzing natural hazard issues in integrated development projects.

Data manipulated by a computer-based GIS are arranged in one of two ways: by raster or by vector. The raster model uses grid cells to reference and store information. An area for study is divided into a grid or matrix of square (sometimes rectangular) cells identical in size, and information-attributes represented as sets of numbers-is stored in each cell for each layer or attribute of the database. A cell can display either the dominant feature found in that cell or the percentage distribution of all attributes found in the same cell. Raster-based systems define spatial relationships between variables more clearly than their vector-based counterparts, but the coarser resolution caused by using a cell structure reduces spatial accuracy.

Vector data are a closer translation of the original map. These systems reference all information as points, lines or polygons, and assign a unique set of X, Y coordinates to each attribute. Usually, vector system software programs have the capability to enlarge a small portion of a map to show greater detail or to reduce an area and show it in the regional context. Vector data can offer a larger number of possible overlay inputs or layers of data with greater ease. The vector model does represent the mapped areas more accurately than a raster system, but because each layer is defined uniquely, analyzing information from different layers is considerably more difficult.

The choice of raster or vector-based GIS depends on the user's needs. Vector systems, however, demand highly skilled operators and may also require more time and more expensive equipment, particularly for output procedures. Vector-based GIS software is also much more complex than that for the raster system and should be checked for performance in all cases. It is up to the planner or decision-maker to choose what system is most appropriate.

### **GIS applications:**

**1.Mapping locations:** GIS can be used to map locations. GIS allows the creation of maps through automated mapping, data capture, and surveying analysis tools.

**2.Mapping quantities:** People map quantities, like where the most and least are, to find places that meet their criteria and take action, or to see the relationships between places. This gives an additional level of information beyond simply mapping the locations of features.

**3.Mapping densities:** While you can see concentrations by simply mapping the locations of features, in areas with many features it may be difficult to see which areas have a higher concentration than others. A density map lets you measure the number of features using a uniform areal unit, such as acres or square miles, so you can clearly see the distribution.

**4.Finding distances:** GIS can be used to find out what's occurring within a set distance of a feature.

**5.Mapping and monitoring change:** GIS can be used to map the change in an area to anticipate future conditions, decide on a course of action, or to evaluate the results of an action or policy.

### **Components of GIS:**

GIS enables the user to input, manage, manipulate, analyze, and display geographically referenced data using a computerized system. To perform various operations with GIS, the components of GIS such as software, hardware, data, people and methods are essential.

#### **Software**

GIS software provides the functions and tools needed to store, analyze, and display geographic information. Key software components are (a) a database management system (DBMS) (b) tools for the input and manipulation of geographic information (c) tools that support geographic query, analysis, and visualization (d) a graphical user interface (GUI) for easy access to tools. GIS software are either commercial software or software developed on Open Source domain, which are available for free. However, the commercial software is copyright protected, can be expensive and is available in terms number of licensees.

Currently available commercial GIS software includes Arc/Info, Intergraph, MapInfo, Gram++ etc. Out of these Arc/Info is the most popular software package. And, the open source software are AMS/MARS etc.

#### **Hardware**

Hardware is the computer on which a GIS operates. Today, GIS runs on a wide range of hardware types, from centralized computer servers to desktop computers used in stand-alone or networked configurations. Minimum configuration required to Arc/Info Desktop 9.0 GIS application is as follows:

#### **Product: ArcInfo Desktop 9.0**

Platform: PC-Intel

Operating System: Windows XP Professional Edition, Home Edition

Service Packs/Patches: SP 1

SP2 (refer to Limitations)

Shipping/Release Date: May 10, 2004

#### **Hardware Requirements**

CPU Speed: 800 MHz minimum, 1.0 GHz recommended or higher

Processor: Pentium or higher

Memory/RAM: 256 MB minimum, 512 MB recommended or higher

Display Properties: Greater than 256 color depth

Swap Space: 300 MB minimum

Disk Space: Typical 605 MB NTFS, Complete 695 MB FAT32 + 50 MB for installation

Browser: Internet Explorer 6.0 Requirement

(Some features of ArcInfo Desktop 9.0 require a minimum installation of Microsoft Internet Explorer Version 6.0.)

#### **Data**

The most important component of a GIS is the data. Geographic data or Spatial data and related tabular data can be collected in-house or bought from a commercial data provider. Spatial data can be in the form of a map/remotely-

sensed data such as satellite imagery and aerial photography. These data forms must be properly geo-referenced(latitude/longitude). Tabular data can be in the form attribute data that is in some way related to spatial data. Most GIS software comes with inbuilt Database Management Systems (DBMS) to create and maintain a database to help organize and manage data.

### **Users**

GIS technology is of limited value without the users who manage the system and to develop plans for applying it. GIS users range from technical specialists who design and maintain the system to those who use it to help them do their everyday work. These users are largely interested in the results of the analyses and may have no interest or knowledge of the methods of analysis. The user-friendly interface of the GIS software allows the nontechnical users to have easy access to GIS analytical capabilities without needing to know detailed software commands. A simple User Interface (UI) can consist of menus and pull-down graphic windows so that the user can perform required analysis with a few key presses without needing to learn specific commands in detail.

### **Methods**

A successful GIS operates according to a well-designed plan and business rules, which are the models and operating practices unique to each organization.

### **Integration of Spatial and Attribute Information**

*Spatial data integration* is a process in which different geospatial datasets, which may or may not have different spatial coverages, are made compatible with one another. The goal of spatial data integration is to facilitate the analysis, reasoning, querying, or visualization of the integrated spatial data. Figure illustrates the integration of three layers or *themes*: major streets, hospitals, and police districts of the City of Chicago.

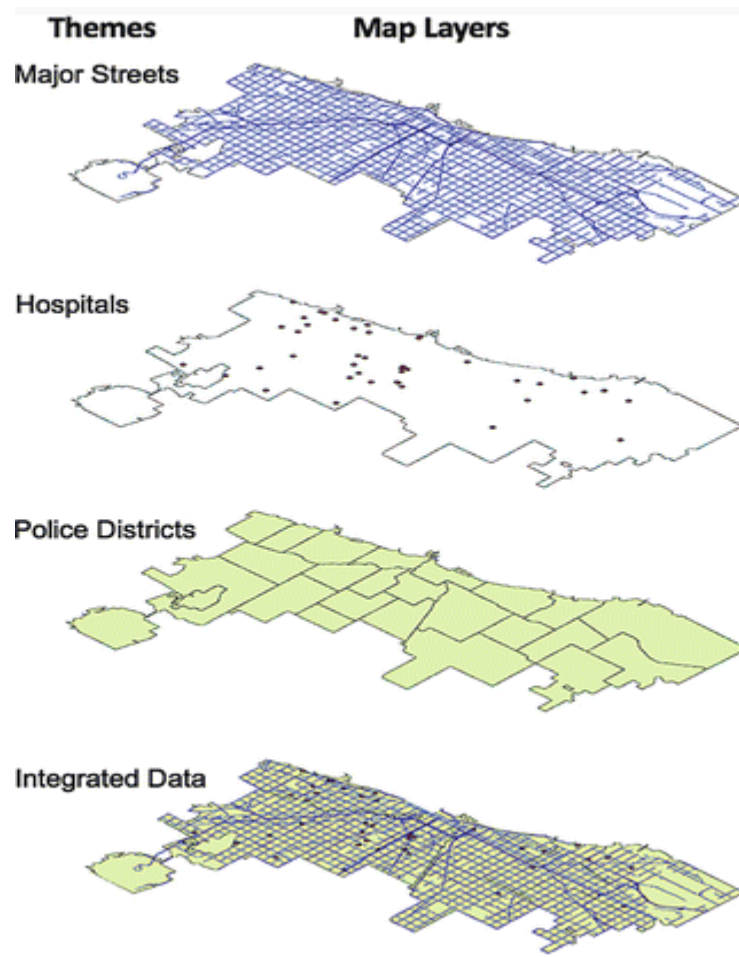

**Fig.** Illustrates the integration of three layers

### **Attribute Information**

There are two components to GIS data: spatial information (coordinate and projection information for spatial features) and attribute data. Attribute data is information appended in tabular format to spatial features. The spatial data is the where and attribute data can contain information about the what, where, and why.

Attribute data provides characteristics about spatial data.

### **Types of Attribute Data**

Attribute data can be store as one of five different field types in a table or database: character, integer, floating, date, and BLOB.

### **Character Data**

The character property (or string) is for text based values such as the name of a street or descriptive values such as the condition of a street. Character attribute data is stored as a series of alphanumeric symbols.

Aside from descriptors, character fields can contain other attribute values such as categories and ranks. For example, a character field may contain the categories for a street: avenue, boulevard, lane, or highway. A character field could also contain the rank, which is a relative ordering of features. For example, a ranking of the traffic load of the street with “1” being the street with the highest traffic.

Character data can be sorted in ascending (A to Z) and descending (Z to A) order.

Since numbers are considered text in this field, those numbers will be sorted

alphabetically which means that a number sequence of 1, 2, 9, 11, 13, 22 would be sorted in ascending order as 1, 11, 13, 2, 22, 9.

Because character data is not numeric, calculations (sum, average, median, etc.) can't be performed on this type of field, even if the value stored in the field are numbers (to do that, the field type would need to be converted to a numeric field).

Character fields can be summarized to produced counts (e.g. the number of features that have been categorized as "avenue").

### **Numeric Data**

Integer and floating are numerical values (see: the difference between floating and integer values). Within the integer type, there is a further division between short and long integer values. As would be expected, short integers store numeric values without fractional values for a shorter range than long integers. Floating point attribute values store numeric values with fractional values. Therefore, floating point values are for numeric values with decimal points (i.e numbers to the right of the decimal point as opposed to whole values).

Numeric values will be sorted in sequentially either in ascending (1 to 10) or descending (10 to 1) order.

Numerical value fields can have operations performed such as calculating the sum or average value. Numerical field values can be a count (e.g. the total number of students at a school) or be a ratio (e.g. the percentage of students that are girls at a school).

### **Date/Time Data**

Date fields contains date and time values.

### **BLOB Data**

BLOB stands for binary large object and this attribute type is used for storing information such images, multimedia, or bits of code in a field. This field stores object linking and embedding (OLE) which are objects created in other applications such as images and multimedia and linked from the BLOB field.

### **Three Vies of Information System**

Many have characterized GIS as one of the most powerful of all information technologies because it focuses on integrating knowledge from multiple sources and creates a crosscutting environment for collaboration. In addition, GIS is attractive to most people who encounter it because it is both intuitive and cognitive. It combines a powerful visualization environment with a strong analytic and modeling framework that is rooted in the science of geography. This combination has resulted in a technology that is science based; trusted; and easily communicated across cultures, social classes, languages, and disciplines. To support this vision, GIS combines three fundamental aspects or views:

1. **The geo database view.** A GIS manages geographic information. One way to think of a GIS is as a spatial database containing datasets that represent geographic information in terms of a generic GIS data model— features, rasters, attributes, topologies, networks, and so forth.



GIS datasets are like map layers; they are geographically referenced so that they overlay onto the earth's surface. In many cases, the features (points, lines, and polygons) share spatial relationships with one another. For example, adjacent features share a common boundary. Many linear features connect at their endpoints. Many point locations fall along linear features (e.g., address locations along roads).

2. **The map view.** A GIS is a set of intelligent maps and other views that show features and feature relationships on the earth's surface. Various map views of the underlying geographic information can be constructed and used as windows into the geographic database to support query, analysis, and editing of geographic information. Each GIS has a series of two-dimensional (2D) and three-dimensional (3D) map applications that provide rich tools for working with geographic information through these views.

3. **The geoprocessing view.** A GIS is a set of information transformation tools that derive new information from existing datasets. These geoprocessing functions take information from existing datasets, apply analytic functions, and write results into new derived datasets. Geoprocessing involves the ability to string together a series of operations so that users can perform spatial analysis and automate data processing—all by assembling an ordered sequence of operations.

There are numerous spatial operators that can be applied to GIS data. The ability to derive new information within a GIS analysis process is one of the fundamental capabilities in GIS.

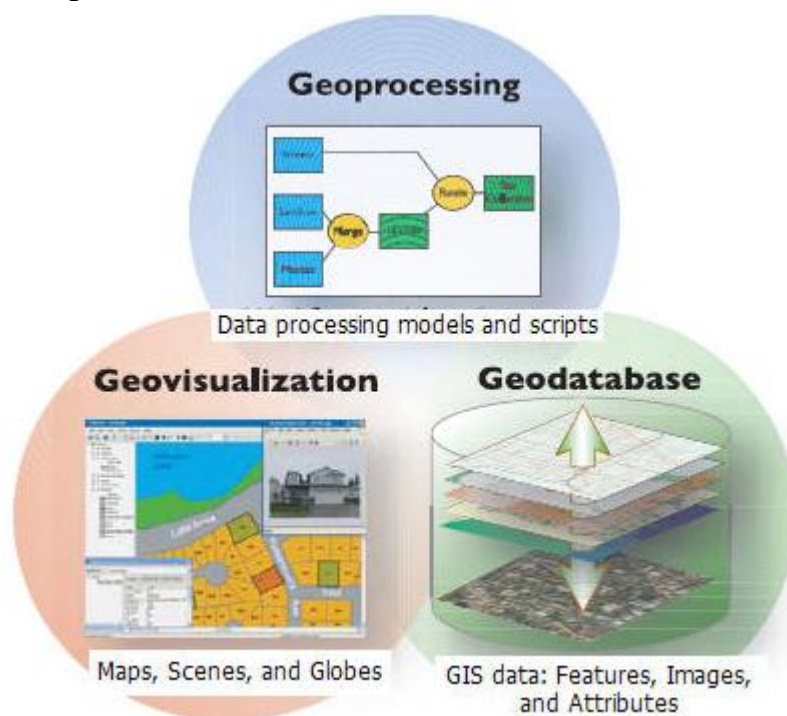

**Fig.** Three Views of GIS

### **Spatial Data Model**

A data model is a way of defining and representing real world surfaces and characteristics in GIS. There are two primary types of spatial data models: Vector and Raster.

- Vector data represents features as discrete points, lines, and polygons

- Raster data represents features as a rectangular matrix of square cells (pixels)

### Vector Data Model:

Vector data is very common, and is often used to represent features like roads and boundaries. Vector data comes in the form of points and lines that are geometrically and mathematically associated.

### Types of Vector Data

#### Points:

- ❖ One pair of coordinates defines the location of a point feature.
- ❖ Individual X,Y

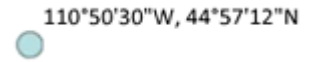

#### Polylines (LineStrings):

- ❖ Two or more pairs of coordinates that are connected define a line feature.
- ❖ A series of connected points - Actually, a set of series of connected points.

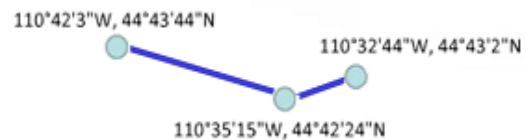

#### Polygons:

- ❖ Multiple pairs of coordinates that are connected and closed define a polygon feature.
- ❖ A series of connected points that loop back to the first point
  - Multiple "polygons" can exist in one layer
  - Polygons can have internal polygons or "holes"
  - The beginning and ending coordinates for a polygon are the same.



### Raster Data Model:

Raster data models represents surfaces as a matrix of cells, more commonly known as pixels, that are organized into rows and columns. Each cell contains a value that represents data. When you use a digital camera to capture a photo, your image is being stored as raster data. In remote sensing, a majority of the data encountered is raster data. The below image is a Digital Elevation Model (DEM) which is a common type of raster data. Each pixel represents the elevation of the area on the ground. Raster data models can be used to store reflectance data, elevation data and categorical data like soil or land cover type.

Raster datasets are composed of rectangular arrays of regularly spaced square grid cells. Each cell has a value, representing a property or attribute of interest. While any type of geographic data can be stored in raster format, raster datasets are especially suited to the representation of continuous, rather than discrete, data. Some examples of continuous data are:

- ❖ oil depth across an open-water oil spill
- ❖ soil pH
- ❖ reflectance in a certain band in the electromagnetic spectrum
- ❖ elevation

- ❖ landform aspect (compass bearing of steepest downward descent)
- ❖ salinity of a water body

Here is a diagrammatic model of how raster datasets represent real-world features:

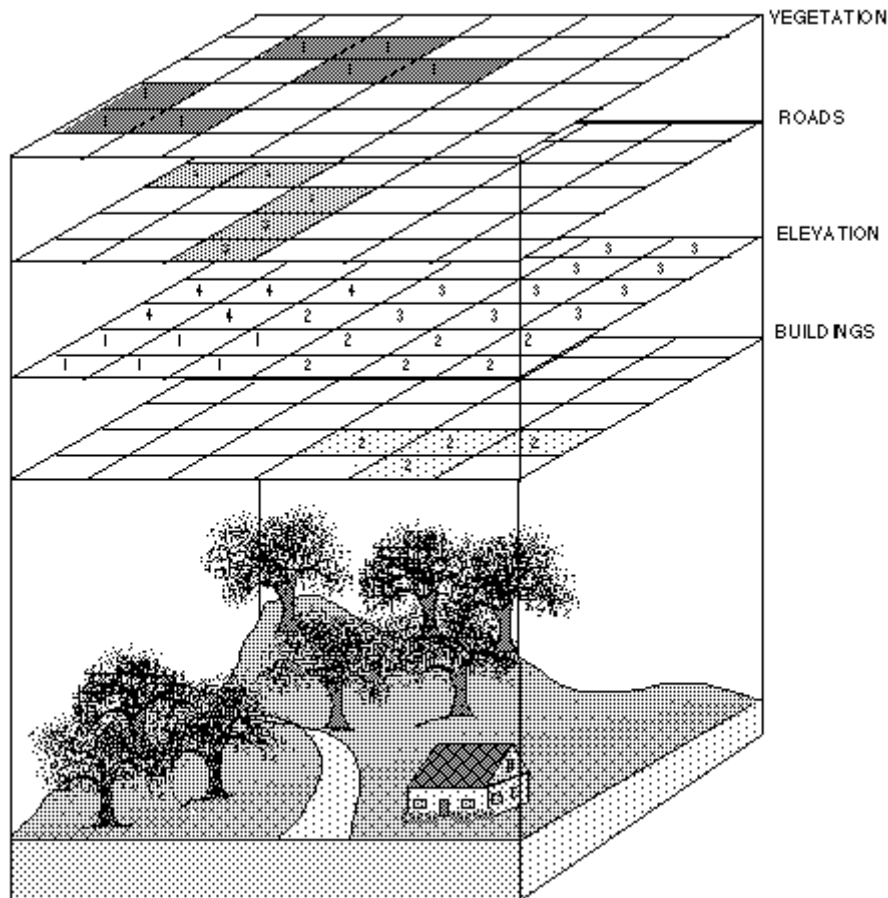

Generally, cells are assigned a single numeric value, but with GRID (a proprietary ArcInfo data format) layers, cell values can also contain additional text and numeric attributes. ArcInfo format grids are the native raster dataset for ArcGIS as well as ArcInfo. In the above diagram, each feature type on the landscape (buildings, elevation, roads, vegetation) is represented in its own raster layer. Note that each raster layer has cells with numbers.

- ❖ For the buildings layer, all cell values are 2 (in this case, 2 is a code for houses; other buildings would be encoded with a different value).
- ❖ For the elevation layer, the cell value is the elevation at the center of the cell.
- ❖ For roads, a value of 3 indicates a road (other road features, e.g., highways, would have a different code).
- ❖ For vegetation, trees have a value of 1. In this example, grass is treated as a background value and has no data value (although it could have been given a different numeric value).

All raster datasets are spatially referenced by a very simple method: only one corner of the raster layer is georeferenced. Because cell size is constant in both X and Y directions, cell locations are referenced by row/column designations, rather than with explicit coordinates for the location of each cell's center. This image shows the upper-left corner as the grid origin, with arrows representing the X and Y location of the cells. Different raster file formats may have an origin located at

the lower left rather than at the upper left. Each cell or pixel contains a value representing some numerical phenomenon, or a code use for referencing to a non-numerical value.

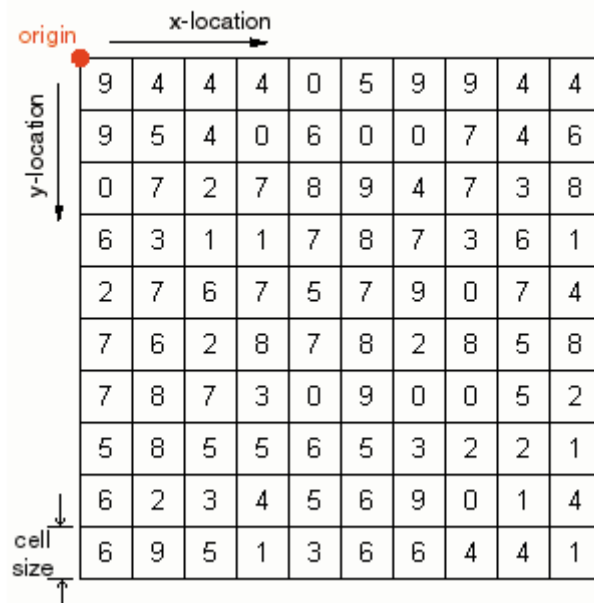

Whereas with vector data, each point, node, and vertex has an explicit and absolute coordinate location, raster cells are georeferenced relative to the layer's coordinate origin. This speeds up processing time immensely in comparison to certain types of vector data processing. However, the file sizes of raster datasets can be very large in comparison to vector datasets representing the same phenomenon for the same spatial area. Also, there is a geometric relationship between raster resolution and file size. A raster dataset with cells half as large (e.g., 10 m on a side instead of 20 m on a side) may take up 4 times as much storage space, because it takes four 10 m cells to fit in the space of a single 20 m cell. The following image shows the difference in cell sizes, area, and number of cells for two configurations of the same total area:

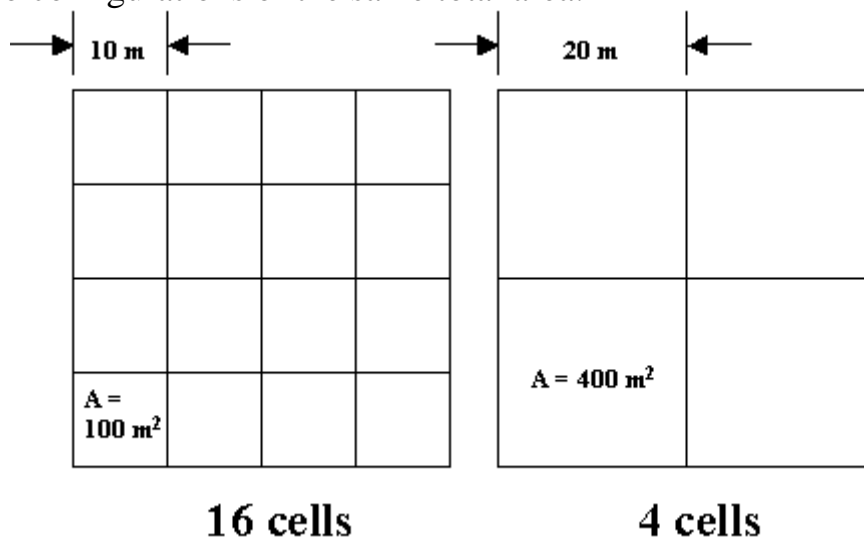

Cells may either have a value (0-infinity) or no value (null, or no data). The difference between these is important. Null values mean that data either fall outside the study area boundary, or that data were either not collected or not available for those cells. In general, when null cells are used in analysis, the output value at a the same cell location is also a null value. Grid datasets can

store either integer or floating-point (decimal) data values, though some other data formats can only store integer values. Typical simple image data will have strict limits on the number of unique cell values (typically 0-255).

**Pixel** or **cell**? All raster datasets are stored in similar formats. You will want to know the difference between a pixel and a cell, even though they are functionally equivalent. A pixel (short for PICTureELement) represents the smallest resolvable "piece" of a scanned image, whereas a cell represents a user-defined area representing a phenomenon. A pixel is always a cell, but a cell is not always a pixel.

There are many types of raster data you may be familiar with:

- ❖ grids (ArcGIS & ArcInfo specific)
- ❖ graphical images (TIFF, JPEG, BMP, GIF, etc.)
- ❖ USGS DEM (Digital Elevation Model)
- ❖ remotely-sensed images (Landsat, SPOT, AVIRIS, AVHRR, Imagine IMG, digital orthophotos)

All raster datasets have essentially the same tessellated structure. Here are few graphical examples of raster data. Note that each image, when zoomed in, shows the same pixellated structure.

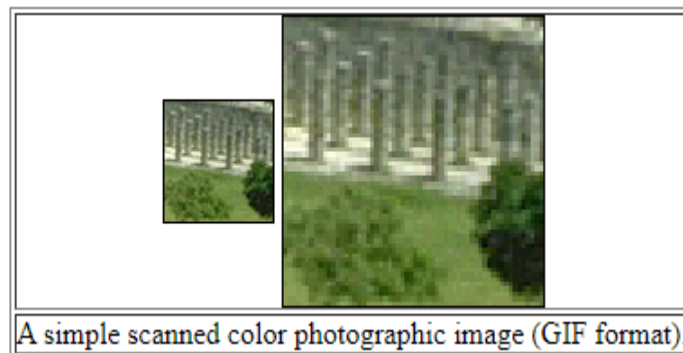

A simple scanned color photographic image (GIF format).

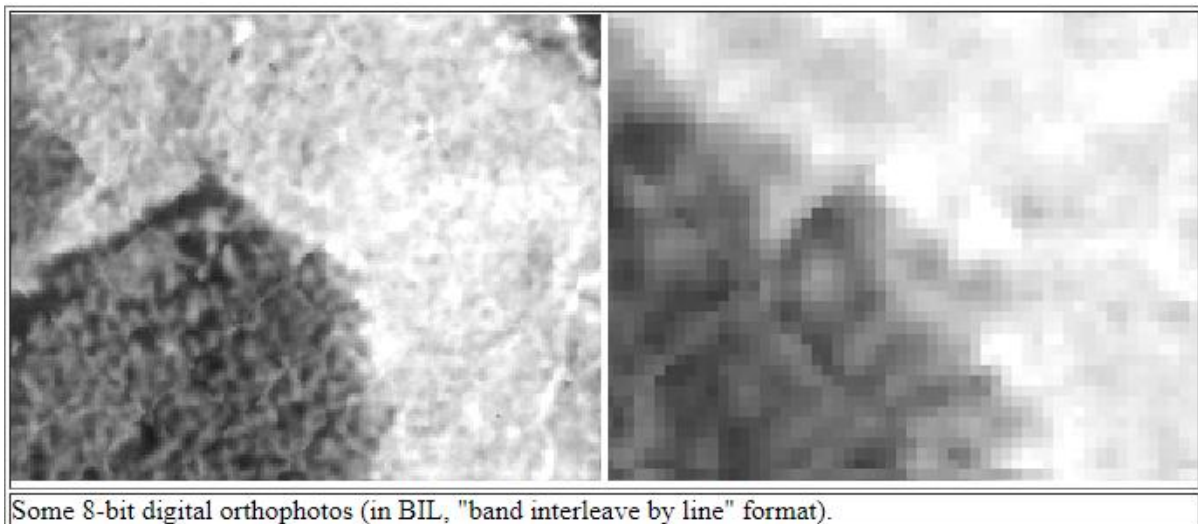

Some 8-bit digital orthophotos (in BIL, "band interleave by line" format).

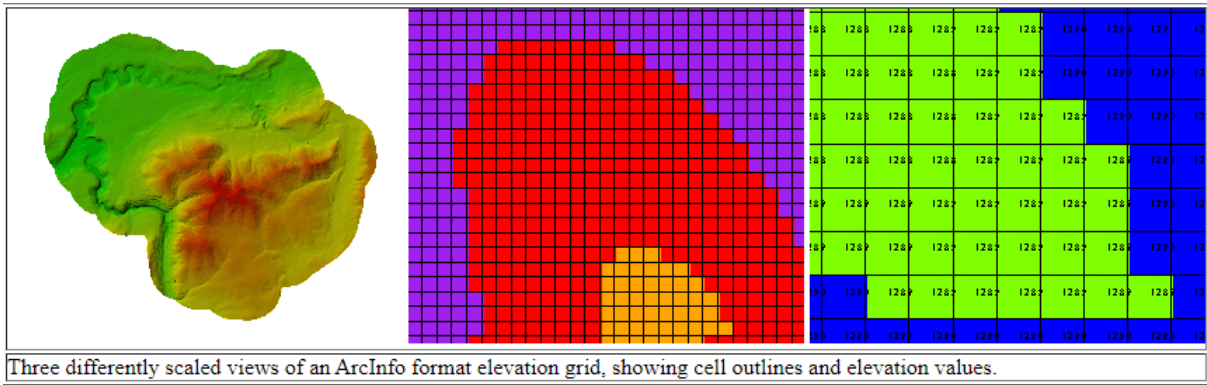

Most of the raster datasets we will use are single-band, which means that they contain a single "layer" of data. The data can represent elevation, slope, or reflectance (in the case of the black-and-white digital orthophotos we will see later).

These single-band images are viewed with a color mapping, so that the cell value is associated with a particular color. For the orthophotos, the color map is a 256-value greyscale ramp. Other raster data, such as elevation models, can be mapped to color ramps that display elevation ranges, as shown in the image directly above. Most GIF files have a limit of 256 unique values (this is known as 8-bit data, because  $2^8 = 256$ ).

Multi-band raster data (such as RGB images or satellite images) are generally displayed with a mixture of red, green, and blue values for each different band in the image.

As you can see, when any of the raster layers are displayed at larger scales, the individual cells become visible. As scale of display increases, precision also decreases, and shapes cannot be precisely represented. All spatial datasets are generalized; however, raster datasets more clearly show their level of generalization. A more complete discussion of generalization in relation to scale is addressed in [Scale Issues](#).

USGS DEMs (Digital Elevation Models) are ASCII (plain text) files which contain georeferencing information as well as point data for elevations on the surface of the earth. Here are the first few lines in the Eatonville, WA 7.5' 30 m DEM:

```

EATONVILLE, WA 464512215 80000 HAP-81 78-73 08/06/81 BC2 30MX30M INTERVA
EATONVILLE, WA 464512215 F5 1 1 1 10 0.000000000000000000000000000000
0.00000000000000000000000000000000000000000000000000000000000000000000
0.00000000000000000000000000000000000000000000000000000000000000000000
0.00000000000000000000000000000000000000000000000000000000000000000000
0.00000000000000000000000000000000000000000000000000000000000000000000
0.00000000000000000000000000000000000000000000000000000000000000000000
0.00000000000000000000000000000000000000000000000000000000000000000000
0.00000000000000000000000000000000000000000000000000000000000000000000
0.51773543640000000000000000000000000000000000000000000000000000000000
0.55715367950000000000000000000000000000000000000000000000000000000000
0.51774378130000000000000000000000000000000000000000000000000000000000
0.00000000000000000000000000000000000000000000000000000000000000000000
1 1 92 1 0.54765000000000000000000000000000000000000000000000000000000000
0.17000000000000000000000000000000000000000000000000000000000000000000
0.27100000000000000000000000000000000000000000000000000000000000000000
214 214 215 215 221 227 233
240 246 252 257 261 266 264 262 260 262 263 265 266 266 267 268 269 271
270 269 268 268 268 268 267 265 264 263 262 261 261 261 260 259 258
258 258 258 256 254 251 245 239 233 229 225 221 216 212 208 204 200 196
194 192 190 190 190 191 190 190 189 189 188 188 188 188 189 188 187 187
187 186 186 184 183 181 180 179 177 175 173 172 170
1 2 218 1 0.54768000000000000000000000000000000000000000000000000000000000
0.13300000000000000000000000000000000000000000000000000000000000000000
0.42500000000000000000000000000000000000000000000000000000000000000000
393 396 400 403 408 414 419
421 423 425 423 422 420 412 403 395 391 386 382 373 365 357 347 338 329
324 318 313 312 312 311 308 305 302 301 300 299 297 295 293 289 285 281
279 277 275 270 265 260 253 247 241 233 226 218 216 213 211 209 207 205
205 205 204 202 200 197 197 197 197 197 198 199 200 201 206 211 216
218 219 221 216 211 207 186 166 145 142 138 135 135 135 135 135 135
134 134 133 134 135 136 135 135 134 148 163 177 185 192 200 202 203 205
206 208 209 210 212 213 213 213 213 213 214 214 214 215 219 224 229
235 241 248 253 258 263 262 261 260 261 263 265 266
266 267 268 269 270 269 268 267 267 267 267 265 264 263 262 261 259 260
260 261 259 257 255 255 255 254 252 250 248 243 238 233 228 224 220 216
212 207 204 200 197 195 193 192 191 191 191 190 190 189 189 188 188 188
188 188 188 187 187 186 186 186 184 183 182 180 179 177 176 174 172 171

```

The first line lists the file name, data input type (HAP = High Altitude Photography), cell size (30MX30M). The subsequent lines list elevations for the lattice mesh points (cell centers).

The DEM file is a data source that is not directly usable in most GIS software, but it can be easily imported into ArcGIS, and used for display and analysis.

### **Attribute data Management and Metadata Concept**

Metadata is like an instruction manual for data.

It describes the who, what, when, where, why and how for data.

It's important because it's the record we rely on to find out how it was created.

That's why it has to be detailed, dependable and well-documented.

Let's explore step-by-step the anatomy of metadata.

Here's the necessary stuff you have to incorporate in metadata.

#### **Identification**

Identification provides a brief narrative of your data. It summarizes the purpose of your data in a succinct way. For example, identification assigns a title, description and keywords to your metadata. By adding keywords, it helps categorize your data with predefined taxonomy.

#### **Contact**

Contact information includes an originator, publisher and distributor. The originator is who developed the data set. Next, the publisher assists in producing, editing and finalizing the end-product. Finally, the distributor's main focus is making the data available.

#### **Quality**

Quality explains the accuracy and standards the data set followed. For example, the horizontal and vertical position accuracy evaluates the ground position quality. Tests of quality include the completeness, integrity and inspections of the data.

#### **Spatial Reference**

Spatial reference information assigns a geographic extent and coordinate system. Projection information includes a projection, datum and units. For example, [UTM Zones](#) and [State Plane](#) are common coordinate systems. Geographic extent comes in the form of a bounding box, place keyword or thumbnail.

### **Entity and Attribute**

Entities refer to the map data type such as points, line, polygons or grids. The purpose of this metadata item is to describe how the spatial information in the data is represented. For the entity attributes, it includes a description with a list of valid values and domains.

### **Lineage**

Lineage describes in detail how the dataset was constructed. For example, it lists the processing steps and responsible parties. Each processing step has a date when it took place so users can track changes. It's like a changelog listing the evolution of the data from start to finish.

### **Legal**

The legal section outlines the constraints for accessing and distributing the data. It describes the liability to assure protection of privacy and intellectual property. Metadata includes a security classification which handles the restriction over security concerns. For example, confidential, restricted, sensitive, unrestricted and unclassified are examples of security classification in metadata.

### **Temporal**

Temporal information focuses on when the data were collected or updated and how long it's valid for. It also states the progress such as when future updates are scheduled. The frequency of updates can be anywhere from daily, weekly, monthly or annually.

### **Metadata Reference**

The metadata reference section is specific to the metadata. It gives a point of contact when there are uncertainties such as how to cite information when used. The metadata reference has a temporal component for the date it was created and when it will be revised next.

### **Metadata Standard**

For GIS metadata standards, geographic data providers follow guidelines from the [Federal Geographic Data Committee \(FGDC\)](#), ISO 19115, EPA, Esri, Inspire and MEDIN. Each schema was developed to best suit their particular requirements and needs. More on this later.

### **Types of Metadata**

Several committees from around the world have developed their own guidelines for metadata. In terms of GIS metadata, the most common are as follows:



- ❖ ISO 19115 is the guideline from the [International Standards Organization \(ISO\)](#).
- ❖ Federal Geographic Data Committee (FGDC) metadata is largely used in the United States.
- ❖ [Inspire metadata](#) defines standards for 34 spatial data themes for countries in the European Union.
- ❖ The [EPA metadata editor](#) was developed by the Environmental Protection Agency (EPA).

There are tools to translate content from one metadata standard to another. For example, Esri's metadata translator can convert into a stand-alone XML metadata.

However, keep in mind that not all fields will get carried over. If one field isn't part of another metadata standard, then it will be missing by default.

## Prepare data adding to Arc Map.

### Arc Map

ArcMap lets you create and interact with maps. In ArcMap, you can view, edit, and analyze your geographic data.

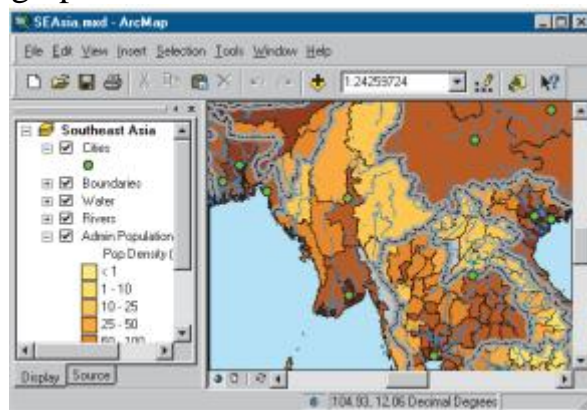

You can query your spatial data to find and understand relationships among geographic features.

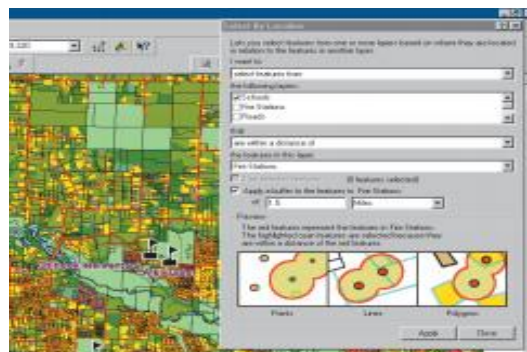

You can symbolize your data in a wide variety of ways.

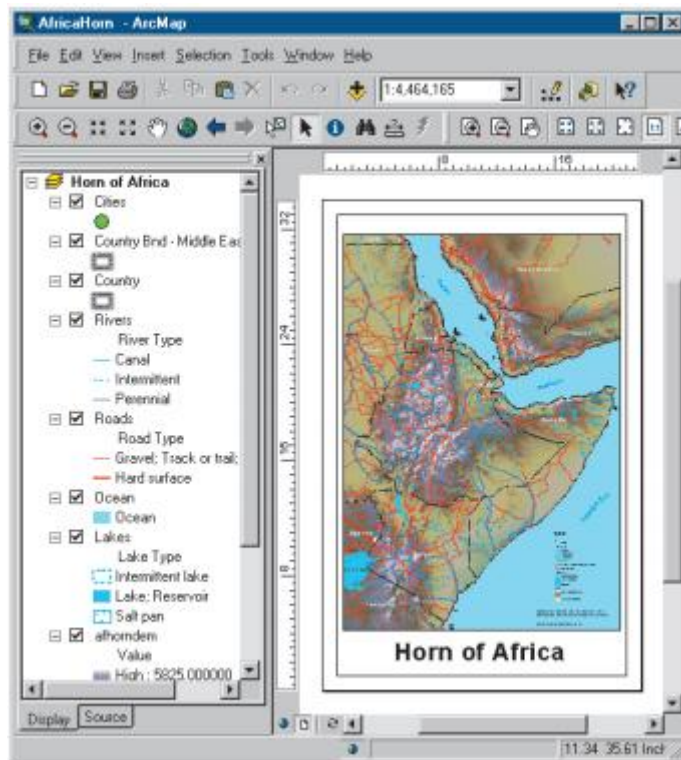

You can create charts and reports to communicate your understanding with others.

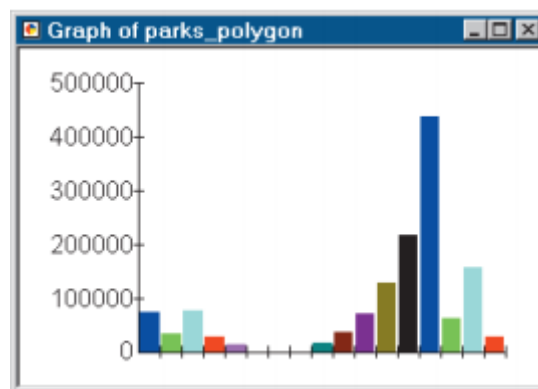

You can lay out your maps in a what-you-see-is-what-you-get layout view.



With ArcMap, you can create maps that integrate data in a wide variety of formats including shapefiles, coverages, tables, computer-aided drafting (CAD) drawings, images, grids, and triangulated irregular networks (TINs).

**Organising data as layers.**

In most GIS software data is organized in themes as data layers. This approach allows data to be input as separate themes and overlaid based on analysis

requirements. This can be conceptualized as vertical layering the characteristics of the earth's surface. The overlay concept is so natural to cartographers and natural resource specialists that it has been built into the design of most CAD vector systems as well. The overlay/layer approach used in CAD systems is used to separate major classes of spatial features. This concept is also used to logically order data in most GIS software. The terminology may differ between GIS software, but the approach is the same. A variety of terms are used to define data layers in commercial GIS software. These include themes, coverages, layers, levels, objects, and feature classes. Data layer and theme are the most common and the least proprietary to any particular GIS software and accordingly, as used throughout the book.

In any GIS project a variety of data layers will be required. These must be identified before the project is started and a priority given to the input or digitizing of the spatial data layers. This is mandatory, as often one data layer contains features that are coincident with another, e.g. lakes can be used to define polygons within the forest inventory data layer. Data layers are commonly defined based on the needs of the user and the availability of data. They are completely user definable.

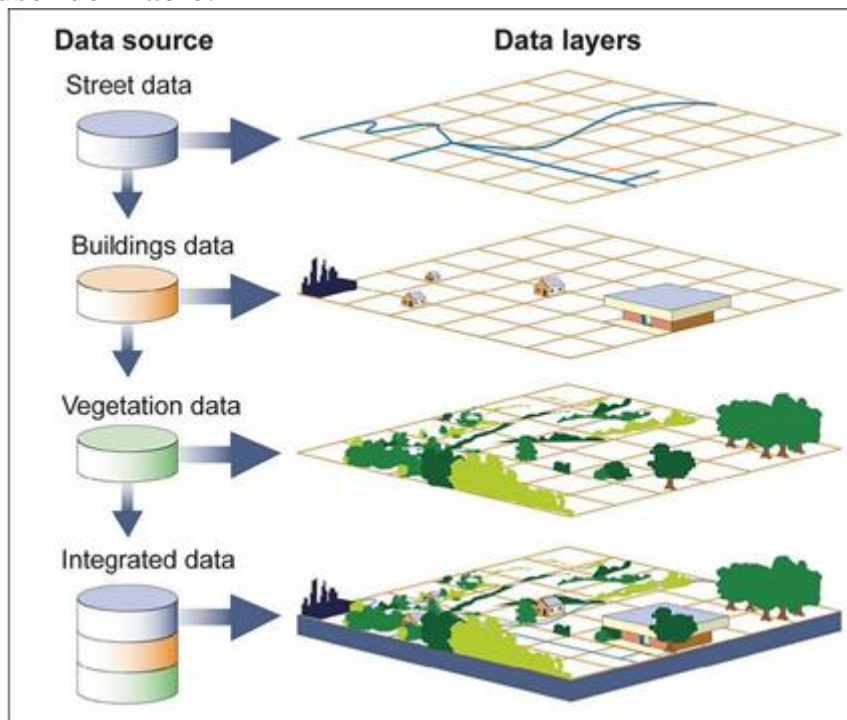

The definition of data layers is fully dependent on the area of interest and the priority needs of the GIS. Layer definitions can vary greatly depending on the intended needs of the GIS.

When considering the physical requirements of the GIS software it is important to understand that two types of data are required for each layer, attribute and spatial data. Commonly, data layers are input into the GIS one layer at a time. As well, often a data layer is completely loaded, e.g. graphic conversion, editing, topological building, attribute conversion, linking, and verification, before the next data layer is started. Because there are several steps involved in completely loading a data layer it can become very confusing if many layers are loaded at once.

The proper identification of layers prior to starting data input is critical. The identification of data layers is often achieved through a *user needs analysis*. The user needs analysis performs several functions including:

- identifying the users;
- educating users with respect to GIS needs;
- identifying information products;
- identifying data requirements for information products;
- prioritizing data requirements and products; and
- determining GIS functional requirements.

Often a user needs assessment will include a review of existing operations, e.g. sometimes called a *situational assessment*, and a *cost-benefit analysis*. The cost-benefit process is well established in conventional data processing and serves as the mechanism to justify acquisition of hardware and software. It defines and compares costs against potential benefits. Most institutions will require this step before a GIS acquisition can be undertaken.

Most GIS projects integrate data layers to create derived themes or layers that represent the result of some calculation or geographic model, e.g. forest merchantability, land use suitability, etc. Derived data layers are completely dependent on the aim of the project.

Each data layer would be input individually and topologically integrated to create combined data layers. Based on the data model, e.g. vector or raster, and the topological structure, selected data analysis functions could be undertaken. It is important to note that in vector based GIS software the topological structure defined can only be traversed by means of unique labels to every feature.

### **Editing the layers.**

GIS allows you to create and edit several kinds of data. You can edit feature data stored in shapefiles and geo-databases, as well as various tabular formats. This includes points, lines, polygons, text (annotations and dimensions), multipatches, and multipoints. You can also edit shared edges and coincident geometry using topologies and geometric networks.

Selecting features identifies the features on which you want to perform certain editing operations. For example, before you move, delete, or copy a feature, you must select it. You must also select features before you can view their attributes in the Attributes window.

You can select geodatabase annotation features using the Edit Annotation tool. Only geodatabase annotation features are selectable with this tool.

While the Edit tool is only available during an edit session, it can select features from any selectable layer, regardless of whether you are currently editing it. The Edit tool works this way because there are various editing operations that can utilize any selected features in your map as inputs for the creation of new data in the layers you are editing—for example, copying a feature in one layer and pasting it in a layer you are editing. To avoid inadvertently selecting from the wrong layer if you have other layers that overlap with or are nearby the features you want to select for editing, make the layer not selectable on the table of contents.

When the Edit tool is active and you are editing the shape of a feature, the Edit tool pointer changes from a black arrow to a white arrow to show you can directly select vertices and modify segments.

### **Switching to Layout View.**

The 'Data View' is used for exploring and editing the data layers. ArcMap also has a 'Layout View', which is used to view and set out maps for exporting and printing.

It is best to finish symbolising your data in the 'Data View' before you begin setting out your layout plan.

### **Change page Orientation.**

ArcMap provides two ways to view a map - data view and layout view. Each view displays the same information but allows for different interactivity; however, the orientation of the data frame can be manipulated.

- a. Via Data Frame Properties
- b. Using Data Frame Tools

### **Removing Borders.**

Satellite imagery sometimes comes with black or white borders. So it is to be required to remove these borders in a mosaic dataset.

To see the value of the pixels, use the Identify tool and click in the border area. Borders that have No Data values can be made transparent in the symbology of the mosaic data set

### **Adding and editing map information.**

ArcGIS allows you to create and edit several kinds of data. You can edit feature data stored in shapefiles and geodatabases, as well as various tabular formats. This includes points, lines, polygons, text (annotations and dimensions), multipatches, and multipoints. You can also edit shared edges and coincident geometry using topologies and geometric networks.

### **Finalize the map**

- Make sure all of the necessary layers are turned on.
- Share the layout by exporting it as a PDF at 300 dpi.
- Search for errors in the PDF. Fix the map. Export again. Repeat until you are satisfied.
- Print the PDF on paper.
- Find more errors on the paper. Fix the map. Export and print again. Repeat until you are satisfied.